



S.R.B Super Scale Series EUROCOPTER EC145

⚠ This product is not intended for children. To ensure the safe use of this product, please be sure to read the instruction manual carefully before use.

EUROCOPTER
Officially Licensed Product

EC145, and **EUROCOPTER** are trade marks of EUROCOPTER. The body design of the helicopter is subject to intellectual property owned by EUROCOPTER. Reproduction authorized by EUROCOPTER.
EC145, 及び **EUROCOPTER** はユーロコプターの登録商標です。ヘリコプターの機体デザインに関する全ての権利はユーロコプターに属します。ユーロコプターより複製許可を頂いております。

Reproduction of SÉCURITÉ CIVILE color and design is authorized by SÉCURITÉ CIVILE.
Reproduction of Schweizerische Rettungsflugwacht (Rega) color and design is authorized by Schweizerische Rettungsflugwacht (Rega).
Reproduction of Police Helicopter Squadron Hessen color and design scheme is authorized by Police Helicopter Squadron Hessen.

00 Before Operating	P2	4. Checking the operability	P49
01 Set Contents	P5	5. Checking the neutral and linkage of the servo	P50
02 Using the Lithium Polymer Battery and Special-Purpose Charger	P7	10 Flight Preparations	P51
03 Using the Transmitter	P9	1. Main blade installation	P51
04 Using the Control Unit	P11	2. Tail blade installation	P52
05 Image Training	P12	3. Installing the Battery	P52
06 Body Assembly	P13	4. Procedure for ON/OFF Power switches	P53
1. Rear body assembly	P14	5. Tracking adjustment	P55
2. Top cover installation	P15	6. Adjusting the rotation speed of the main blade	P56
3. Front body assembly	P15	11 Flight Adjustment	P57
4. Horizontal fin assembly	P16	1. Preflight Inspection	P57
5. Front top cover assembly	P17	2. Taking off a single-rotor helicopter	P59
6. Front top cover and front body installation	P17	3. Aileron and elevator trim adjustment	P60
7. Windows installation	P18	4. Rudder trim adjustment	P61
8. Accessories installation	P19	5. Throttle stick operations practice	P62
9. Accessories installation	P20	6. Practicing rudder operation	P63
10. Skid assembly	P21	7. Practicing hovering	P64
07 Body painting/Decal application	P22	8. Practicing horizontal movement	P65
08 Unit Assembly	P35	9. Practicing pirouettes	P65
1. Center hub and seesaw assembly	P35	12 Unit Maintenance	P66
2. Stabilizer assembly	P35	1. General guidelines on disassembling the flying unit	P66
3. Rotor head assembly	P36	2. Things to be checked after a fall	P67
4. Main frame assembly	P37	13 Checkpoints for Flying Problems	P70
5. Main motor assembly	P38	14 Parts List	P71
6. Rotor head installation	P39	15 Expert level: Using the optional features	P75
7. Control unit and servos installation	P40	1. Adjusting the throttle curve	P75
8. Servo horn assembly	P41	2. Adjusting rudder rotation speed	P76
9. Linkage rod assembly	P42	3. Adjusting the sub-trim in neutral	P76
10. Battery holder installation	P43	4. Adjusting the gyro sensitivity	P77
11. Tail motor installation	P44	5. Switching the gyro sensitivity adjustment channel	P78
12. Back LED installation	P44	6. Resetting the data	P79
13. Body installation	P45	7. Changing tail motor rotation direction	P79
14. Tail motor/Back LED connection	P46	8. Switching the receiver mode	P80
15. Front body installation	P47	Function List	P81
09 Setting the Transmitter and Control Unit	P48	Error Display List	P82
1. Usable Transmitters	P48	List of adjustment items in the S.R.B EC145 control unit	P83
2. Selecting the manufacturer setting	P48	List of switches	P84
3. Switching the receiver mode	P49		



Super Scale Series

EUROCOPTER EC145

Radio Controlled Model + Plastic Model

A "Radio Controlled Model" that offers enjoyable control and a "Plastic Model" that offers an uncanny realism. By combining these two ideas, we produced the ideal model that anyone would covet.

S.R.B. Super Scale Series

S.R.B. Super Scale Series offers scale RC helicopter models created through a collaboration between the RC helicopter technology of Hirobo (Ltd.) and the plastic model molding technology of Tamiya (Inc.). The mechanism uses the SRB series structure created from Hirobo's flight characteristics research with small scale helicopters. As a result, you can enjoy a stable flying experience with the real equipment in these scale model flights. The lightweight plastic body made from injection molding recreates real life-like detailing and is made as thin as possible. These bodies are unprecedented and being completed for our premium models that could even satisfy the scale model enthusiast who appreciates the real thing. After eagerly completing your model, not only can you enjoy it as a decoration, but you can also enjoy a new experience and the real thrill of flying it with your own two hands.

Main Specifications

Body

Fuselage length	382mm/374mm
Fuselage width	107mm
Overall height	141mm
Main rotor dia.	369mm
Tail rotor dia.	106mm
Overall weight	220g (Unpainted)
Gear ratio	Main blade 5.29 : 1
Maximum Flight Time	Approx. 8 to 9 minutes*

* Actual flight time will depend on where the model is flown, and the condition of the battery and fuselage.

Lithium-polymer battery

Voltage	11.1V
Capacity	480mAh

Battery Charger

Input voltage	DC14V~16V
Input current	0.7A or more
Output voltage	12.45V
Output current	0.5 A
Charging method charging	Constant current, constant voltage charging CC-CV

AC power supply adapter for battery charger

Input voltage	AC100V~240V
Output voltage	15V
Output current	0.7A or more

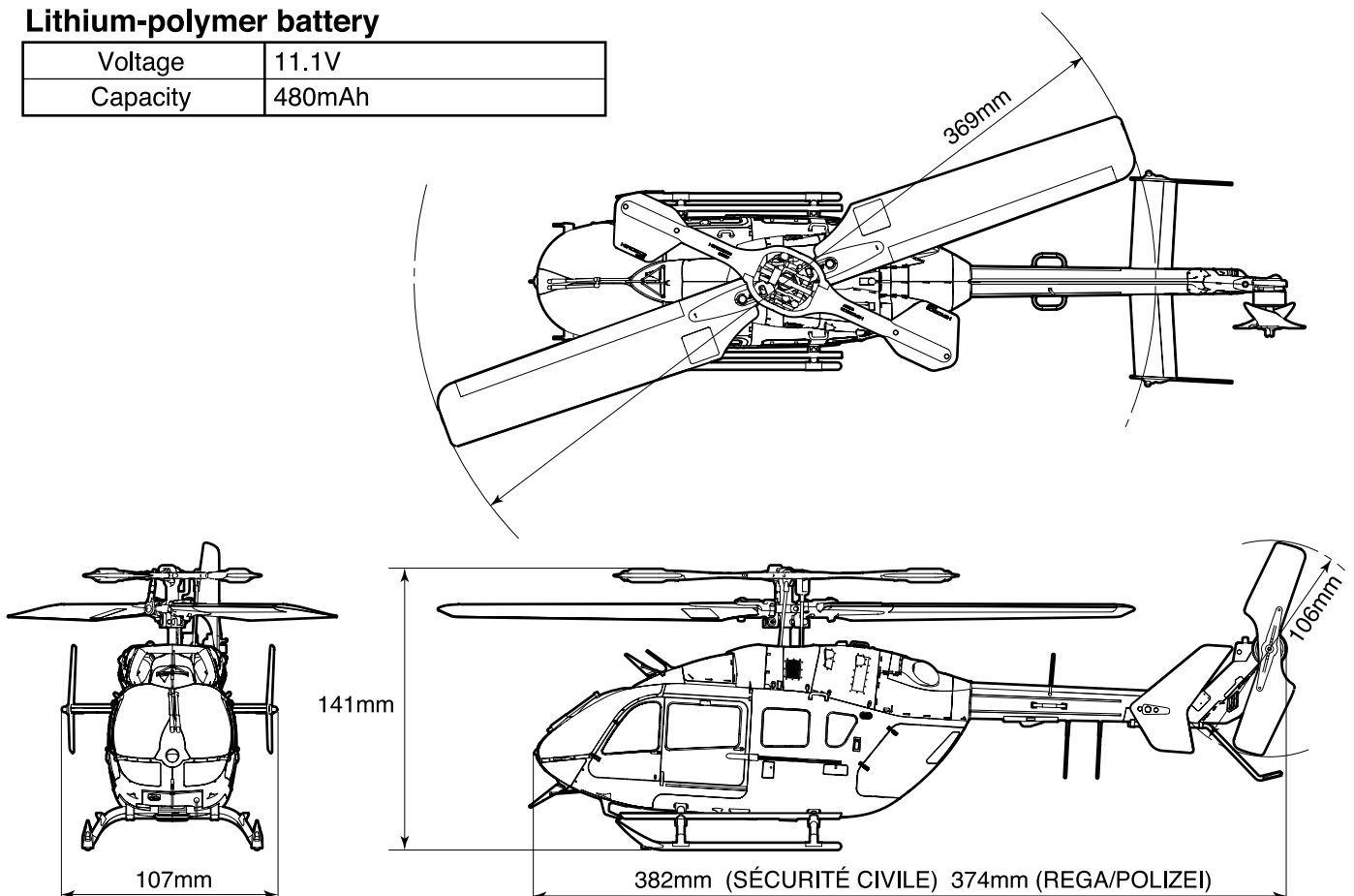

00 / Before Operating

Thank you for your purchasing of a HIROBO product.

To ensure safety, please read this manual thoroughly before flying the model.

We request that you make yourself familiar with the cautions, the flying the capacity of this model plane, how to fly it, and use of this product while observing safety rules and flying manners.

This instruction manual must be looked after and kept where it is readily retrievable.

Product specifications, prices, shapes etc. may change for improvements without prior notice.

● An explanation of the safety symbols used in this manual

This manual contains safety symbols to warn the reader of items that require particular attention to safety. The meanings of these safety symbols are given below.







 **Warning** [warning symbol] If you handle the product in a way that ignores the warning information highlighted by this symbol, it could result in a fatal or serious injury to the user or a bystander or there is a high possibility that a minor injury or some kind of property damage could occur.

 **Caution** [caution symbol] If you handle the product in a way that ignores the caution information highlighted by this symbol, it could result in an injury to the user or a bystander or there is a possibility of some kind of property damage.

 [prohibited action] The prohibited action symbol identifies acts that never should be performed.

 [essential practice] The essential practice symbol identifies practice that must always be followed.

Warning

-  Store the product parts in an area out of reach of infants and children.
They can accidentally activate operation, or put the battery or small parts in their mouth; any of such actions could result in injury or damage caused by chemical substances.
-  Never disassemble or attempt to modify anything other than what is specified in this manual.
Doing so could cause electric shock, an injury, equipment breakdown or a subsequent fire.
-  Do not store the product parts in the following types of locations.
Storing such equipment in these places could cause shape distortion, breakdown and subsequent injury or fire as a direct result of equipment breakdown.
 - Hot places that exceed 40 °C or cold places that fall below -10 °C
 - Places exposed to direct sunlight
 - Places with high humidity, vibration, or lots of dust
 - Places with moisture or steam or where exposed to a source of heat
-  Do not fly the product in the following types of conditions.
 - In strong winds, rain, snow, thunder or other bad weather
 - At night, when the flying unit is difficult to see
 - Near buildings, roads, railways, power lines or airports
 - In crowded areas, or around children or pets
 - In small rooms, or near furniture
 - In areas where other remote controlled models on the same frequency are being used.Jammed electrical signals, incorrect operation, or malfunctions in either the transmitter or main unit may cause the flying unit to crash, possibly colliding with people or objects and causing injury or damage. In addition, moisture, sand or dust may cause the product to malfunction.
-  Always refrain from flying units that use the same radio frequency at the same time. The radio signal interference may cause a crash.
 - * The radio signal interference will still happen when the radio frequency is the same even if a different modulation type is used (AM, FM, PCM etc).
-  Always refrain from touching parts that are installed in the flying unit, namely the motor, pinion gears, motor mounting screws and connectors during use or directly after use. These parts heat up to high temperatures and can cause burns.

⚠ Warning

- ⊘ Never put your hands or face close to rotating parts. Doing so creates the risk of unexpected injury.
 - * When flying the unit indoors or when adjusting it while holding it in your hands, we recommend wearing protective eyeglasses.
- ⊘ The power cord poses an asphyxiation risk if played with by small children or pets and wrapped around the neck.
- ⊘ Never allow young children to use this product. Doing so creates the risk of accident caused by rotating parts or the cord.
- ❗ Always only use the genuine Hirobo battery and charger (for S.R.B EC145). If a non-genuine part is used, Hirobo will not be liable for any loss that arises out of such use. Use only items that are listed in this instruction manual.
- ❗ Always pay attention to the fact that much functionality is required of this product's parts and parts include small items, sharp items and items made from metal. Prevent any possibility of a small child putting these parts in their mouth or getting injured by these parts. If a child swallows a part, seek urgent medical advice. Always discard the packaging of the parts in a place out of reach of children.

⚠ Caution

- ⊘ To avoid such risk, never operate this product while sitting on the floor or on a chair. Operate this product in a posture that allows you to quickly get out of the way if necessary.
- ⊘ To ensure safe practice, never use parts that are damaged or have altered shape in this product.
- ❗ Always power switch off both the flying unit and transmitter when leaving the transmitter unattended. If the power switch is left on, it is possible that unintended stick operation occurs when the transmitter is placed on the floor or a chair.
- ❗ This product is a precision machine that can easily be broken if dropped or used incorrectly. Please check the product before flying to see if there are any broken parts. Always use this product in a way that is proper and safe to maintain its performance.

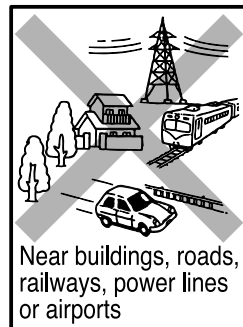
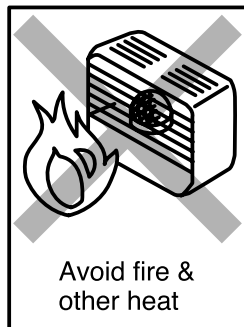
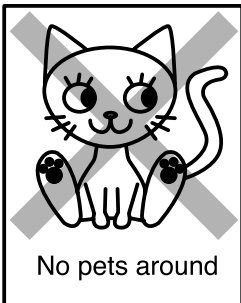

= For details, see "Warning" and "Caution" sections. =

Secure the flight area.

Indoors

Allow a minimum of three meters of clear space around yourself in all directions. If there is an obstruction nearby such as walls or furniture, the SKY ROBO will be drawn to the obstruction.

As you gain experience, you should still practice keeping a safe area.

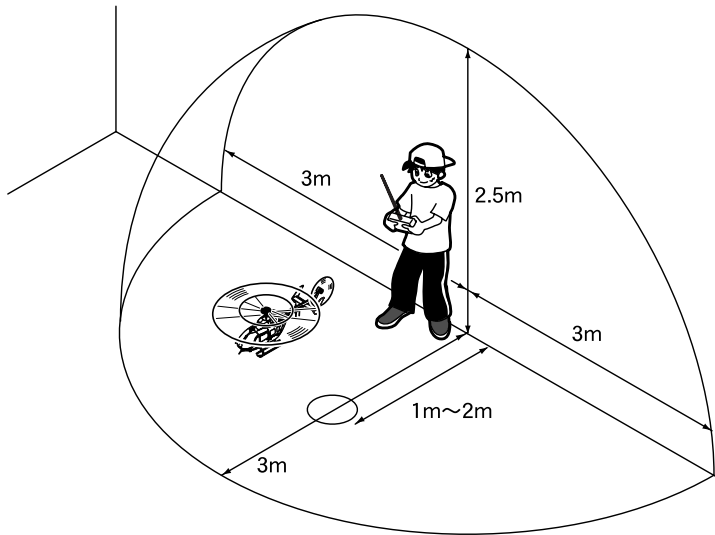

Outdoors

Never fly this product in the following places.

- ⊘ In strong winds, rain, snow, thunder or other bad weather
- ⊘ At night, when the flying unit is difficult to see
- ⊘ Near buildings, roads, railways, power lines or airports
- ⊘ In crowded areas, or around children or pets
- ⊘ When remote-controlled models using the same frequency are nearby

Please read Page 2 and 3 for further details, and focus on flying safely.

Fly the product at times when there is no or only light wind.

Furthermore, control becomes very difficult when the wind speed is **3 m or more**. Please do not attempt to fly this unit in high winds.

⚠ Caution

If other people are using wireless remote-controlled models nearby, be sure to check which frequency they are using. Also, be sure to tell others which band you are using. Attempting to use the same band at the same time may lead to improper operation and is extremely dangerous.

Names of each component

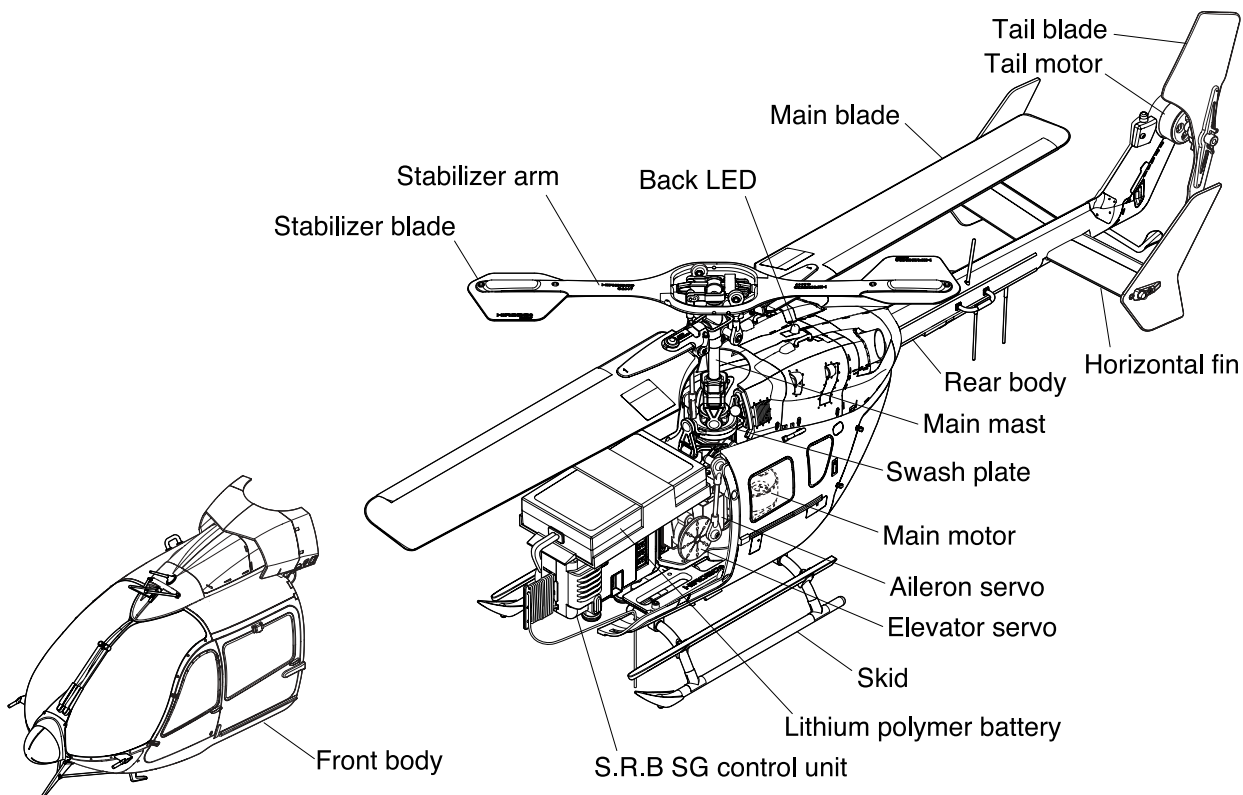

01 / Set Contents

Check that the following components are included.

Full set · Set without the programmable transmitter

Pre-assembled and painted body

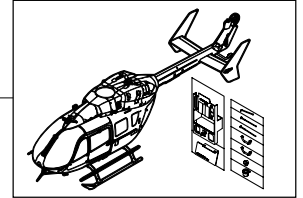

Transmitter
Not included in a set without the programmable transmitter.
* Eight size AA batteries are required.

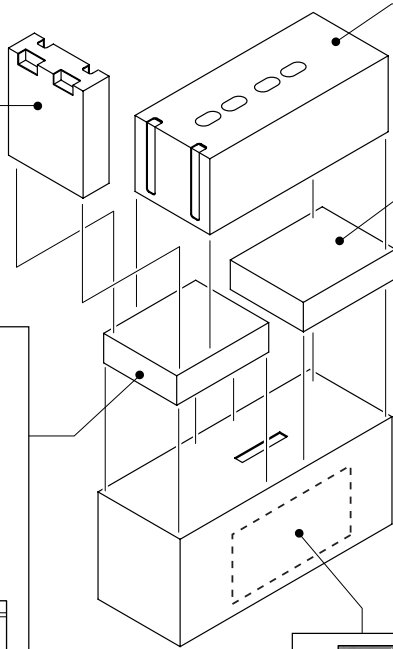

Mechanical assembly

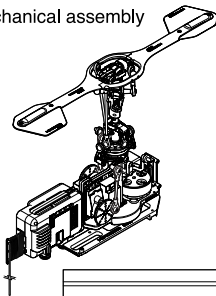

In a bag

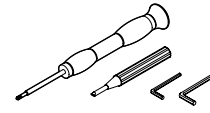

Tools (+, - Screwdriver, Allen wrench 0.89 mm and 1.5 mm between opposite sides)



Blade balancer

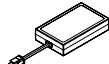

Lipo battery 11.1V 480mAh

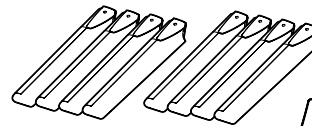

S.R.B SG main blades X 4se
S.R.B tail blades(W)X 4sett

* For optimum safety, the main blades and tail blade are made of styrofoam and should be considered replaceable parts. The main blade cannot be repaired.

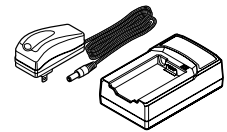

11.1V 3 cell Lipo battery charger



Users manual (this document)



User card



Frequency board

Not included in a set without the programmable transmitter.

Kit

In a bag

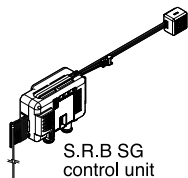

S.R.B SG control unit



Lipo battery 11.1V 480mAh

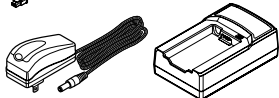

11.1V 3 cell Lipo battery charger



Blade Balancer



Tools (+, - Screwdriver, Allen wrench 0.89 mm and 1.5 mm between opposite sides)

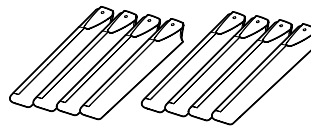

S.R.B SG main blades X 4set

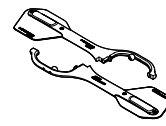

S.R.B SG stabilizer



S.R.B tail blades(W)X 4set

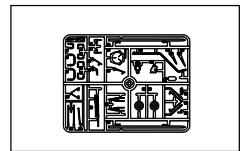
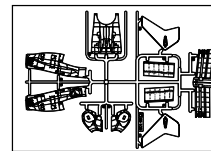
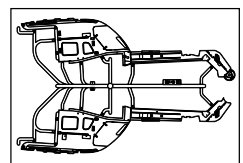
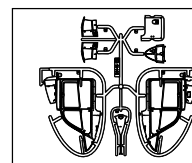

MagnetX 4

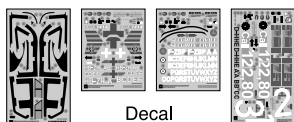

Decal

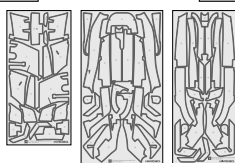

Masking seal



Users manual (this document)



User card

Tools used for assembly

Tools that accompany the product

* The prices in parentheses are the prices excluding consumption tax.

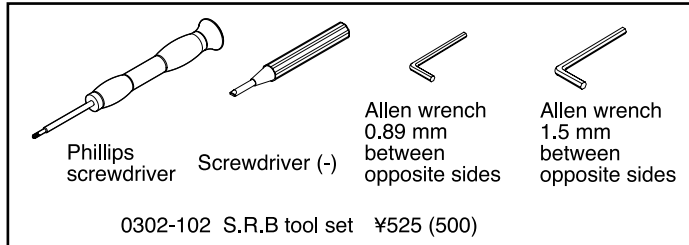

For inquiries regarding product or assembly method:

3-3-1 SAKURAGAOKA, FUCHU-SHI,
HIROSHIMA-PREF, JAPAN 〒726-0006

HIROBO LIMITED

Model Enterprise Company

Or your local HIROBO distributor in your country.

Optional accessories (Sold separately)

Hirobo products

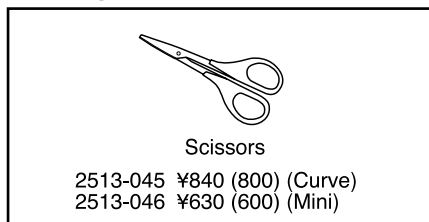

Tamiya products

<p>74007 (+) Screw Driver No.1 M</p> <p>Used for tightening M2 tapping screws.</p>	<p>74020 Design knife</p> <p>74053 Fine craft knife</p>	<p>87030 6mm 87031 10mm 87032 18mm</p> <p>Masking tape</p>	<p>74047 HG angled tweezers</p> <p>74048 HG straight tweezers</p>
<p>Enamel Acrylic</p> <p>TAMIYA color (Paint)</p> <p>We recommend using Tamiya Colors for paint. Colors specified by the kit's paint instructions are all Tamiya colors. Use a spray can (TS, AS, PS) to paint large surfaces and a brush (Tamiya Enamel Paint, Tamiya Acrylic Paint) to paint fine parts.</p>	<p>TAMIYA cement (Plastic model adhesive)</p> <p>87003 40ml 87012 20ml 87038 Extra thin type 40ml</p> <p>Use plastic model adhesive to assemble the body and other plastic parts. Tamiya Cement/Tamiya Cement (extra thin type) is useful for attaching smaller parts.</p>	<p>87102 Mark fit (Decal softener)</p> <p>Used when adhering decals to curved or uneven surfaces.</p>	<p>74001 Side cutter for plastic</p> <p>74035 Sharp pointed side cutter for plastic</p> <p>Used when cutting plastic parts from runners (frames).</p>
<p>87054 P400 87057 P1000</p> <p>Used for plastic parts cut from runners (frames) and evening out surfaces connected using adhesives. Preparing 2 types, a coarse 400 grain and finer 1000 grain for finishing is recommended.</p>	<p>87100 TAMIYA Epoxy cement</p> <p>It is recommended to use a strong epoxy adhesive when attaching pitot tubes, antennas and other small parts.</p>		

02 / Using the Lithium Polymer Battery and Special-Purpose Charger

⚠ Warning

If the lithium polymer battery is overcharged or over discharged or mistreated in another way, it not only could cause the equipment to breakdown, it also could cause the battery to rupture, get abnormally hot or ignite, which is very dangerous. Always adhere to the following instructions and use the lithium polymer battery properly and safely. Hirobo will in no way be held liable for accidents or other incidents occurring as a result of incorrect use of the battery.

- ⊘ Never throw the battery into a fire or heat it up in any way.
Such action could cause the battery to rupture, get abnormally hot or ignite, which could cause an injury, burn or the like.
- ⊘ Never leave the battery inside a car where it can get very hot, in hot weather or in places where the temperature exceeds 40 °C.
- ⊘ Never bash the battery or drop it.
- ⊘ Never wet it with water etc.
- ⊘ Never short the battery by connecting the positive (+) terminal with the negative (-) with a metal object such as a necklace or paper clip.
- ⊘ Never attempt to charge the lithium polymer battery included with this product using anything other than the supplied charger.
This means that not only should you not use NiCd or NiMH battery chargers, you should not use other lithium polymer chargers either. Hirobo will not be held liable for any loss or damage arising from using any recharger other than the charger supplied with this product.
In addition, never attempt to recharge any lithium polymer battery other than the battery supplied with this product using the charger included with this product.
- ⊘ Never use the lithium polymer battery supplied with this product for any equipment other than this product (including other models and electrical products).
- ⊘ Never fly this product using a battery other than the genuine battery.
- ⊘ If you wish to prepare a backup battery, please be sure to purchase a genuine Hirobo battery specifically designed for use with the S.R.B EC145.
- ⊘ Never use an abnormal battery. If during battery use, battery charging or during battery storage, a strange smell is noticed, or the battery begins to get hot, become misshapen or discolored, or you notice anything else that is different about the battery, disconnect the connector immediately and discontinue battery use.
- ⊘ Never use a battery that has shown any sign of abnormal performance. In such a case always replace the battery with a new one.
- ⊘ The connector used for the S.R.B EC145 has a different shape in order to prevent it from being wrongly connected to other RC devices, etc. Be sure to use only Hirobo's genuine connector. Never use a substitute. Also, never attempt to extend or modify the connector.
- ⚠ Always ensure the charger is kept with its plug removed from the power outlet at all times other than when charging.
- ⚠ Always recharge the battery and store it soon after flying because if the battery is over discharged, it can no longer be used.
When the voltage of a single cell falls to 2.7 V or less, it can no longer be reused (recharged).
If you accidentally over-discharge the battery, please purchase a new one.
- ⚠ When recharging is complete, immediately remove the battery from the charger and the power plug from the power outlet. If they are left connected, it may cause damage to the battery and/or the charger.
If the connector remains connected after using the model or charging the battery, it may result in damage, a fire, over-discharge, overcharge, or the model going out of control due to forgetting to turn off the switch. For safe storage, disconnect the connector after using the model or charging the battery. Also prevent the battery from getting wet, and prevent the connector and cord from contacting any metal when storing the battery.

Be sure to close the protective cap when you have finished recharging.

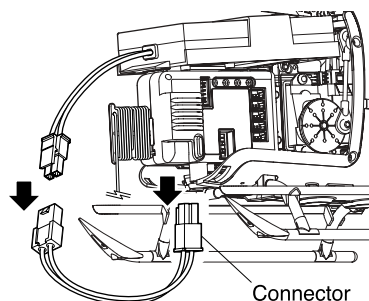
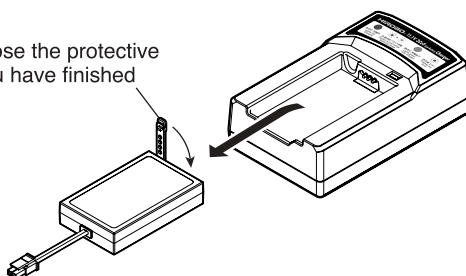

How to recharge the battery / LED display

Follow the steps 1 to 4 illustrated in the figure below and turn on the switch.
Please read the instruction manual while the battery is charging.

1. Connect the charger connection cord to the charger.

2. Plug the cord into a power outlet.

3. Rotate the protective cap to uncover the recharging terminals.
The side with the sticker should face up.

4. Place the battery on the charger.
When the LED lamp lights green, recharging is complete. Recharging takes between 60 to 90 minutes.

LED display		
●	Lights red	Recharging
○	Lights green	Recharging is complete
✱-✱	Flashes red and orange	Balance charging
✱	Flashes green	Flashes when the power is connected
✱	Flashes red	Error
✱-✱	Flashes green and red (orange)	Error (Bad contact)
Errors		
• Overcharge: 4.25 V or higher per cell		
• Over-discharge: 2.7 V or less per cell		
• Reverse connection		
• Short circuit • Contact failure		

One point What is balance charging?

The battery for S.R.B EC145 comprises three cells, connected in series. (Called "3 cell")

Repeatedly charging and discharging the battery causes differences in the voltage produced by each cell. However, in a process called "balance charging", this imbalance is automatically detected and compensated for during charging.

Getting the most from your lithium polymer battery

- If the lithium polymer batteries are excessively discharged, they will become unusable.
Pay careful attention to the following items to avoid excessively discharging the batteries.
 - If the LED starts pulsing in orange, it indicates that the voltage of the battery is lower than the required level. End the flight and replace the battery immediately.
 - Do not discharge using a discharger etc before recharging. (It is possible to recharge lithium polymer batteries when they are not fully discharged without any loss of performance.)
 - Always make sure to charge the batteries after flying the product before storing them. In addition, if the batteries will not be used for a long period of time, periodically recharge them to prevent them from being completely discharged. (The battery will naturally discharge over time even if fully charged.)
- In a cold environment, the battery will not perform as well, the length of time the battery can be used will be shorter and there may be instances where adequate output cannot be achieved. For these reasons, use this product in a warm environment.
- If the usable battery time greatly decreases, this is a sign that the battery has begun to degrade. Purchase a new battery.

Disposing of the battery

The main materials of lithium polymer batteries are lithium and cobalt, which are both sparse resources.
Please recycle the lithium polymer batteries so that these limited resources can be effectively used.
Please follow the rules and regulations in your area on how to recycle or dispose of the batteries.

【If an error is displayed】

Turn off the power either by taking out the lithium polymer battery from the charger and taking out the connecting cord from the charger, or by pulling out the connecting cord from the power outlet. Turn on the power again, and see that the LED on the charger is pulsing in green. Then set the battery on the charger.

If you are unable to recharge the battery even after repeating this procedure, it is likely that the battery has either degraded or been over-discharged, in which case you will need to purchase a new battery.

⚠ Caution

Be careful to avoid electrical shorts.

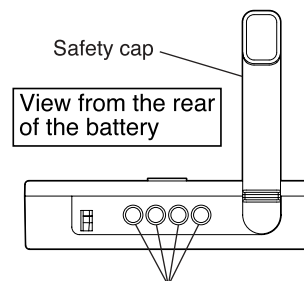

Be careful to ensure that metal objects do not come into direct contact with the terminals. Quickly place the protective cap when you have finished recharging.

Point

If you continue the flight while the LED is pulsing in orange, a fail-safe function will engage and the motor will slow to a stop.

* In this state, the transmitter cannot be used to control the throttle. Use other rudder.

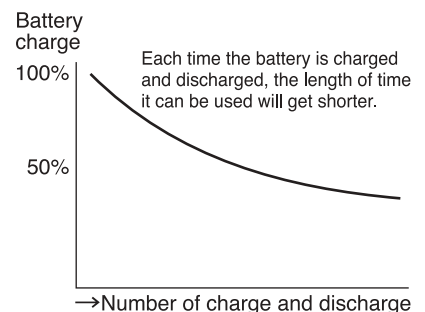

03 / Using the Transmitter

Information on the transmitter that is included in the full set

If you have purchased the set without the programmable transmitter or kit, a transmitter must be obtained separately.

For details, see "09. Setting the Transmitter and Control Unit" on page 48.

● Name and function of the transmitter parts

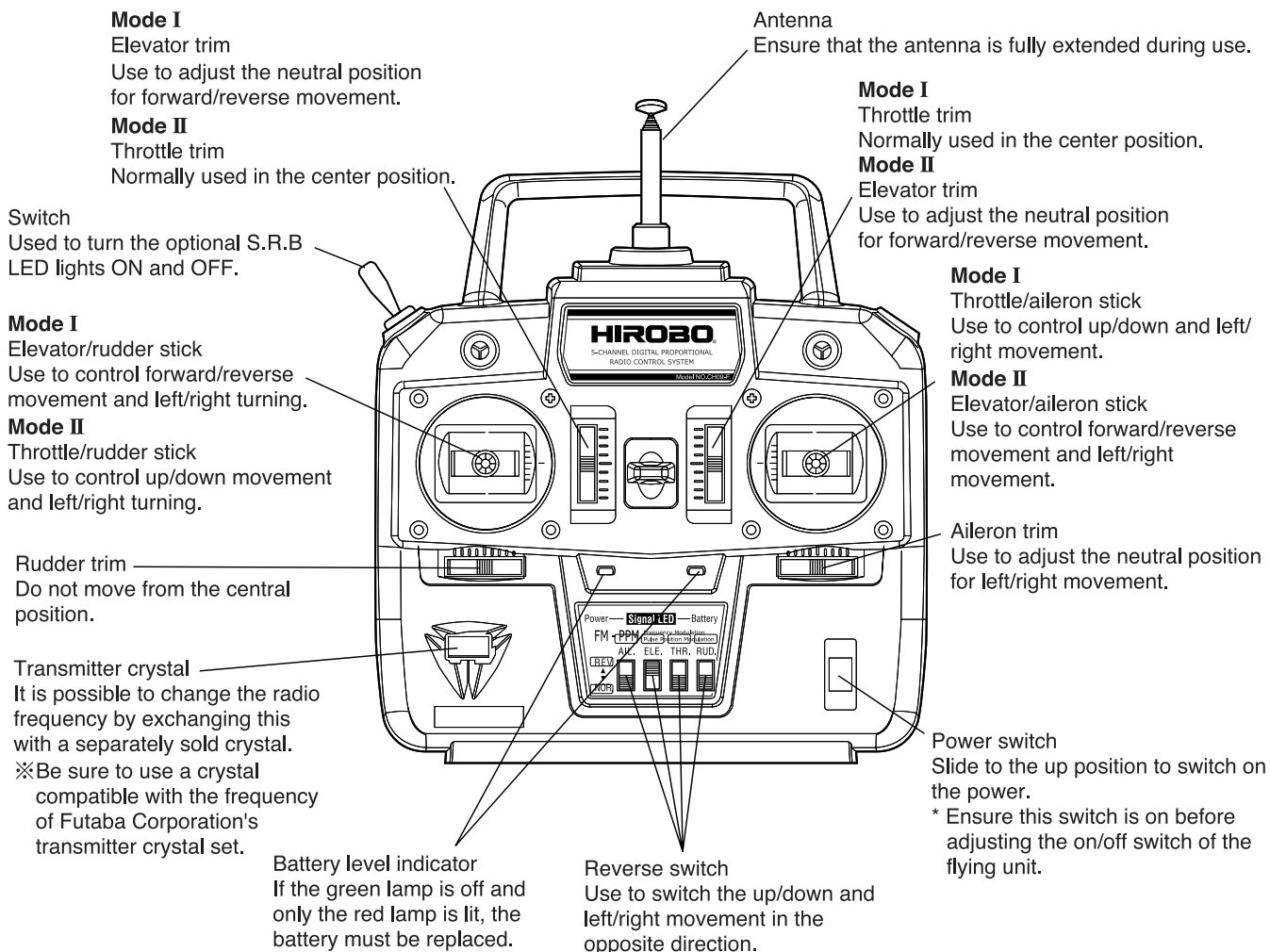

Point

Transmitters with four channels, that come with XRB and S.R.B, can also be used. Set the receiver (control unit) to the same frequency and band when using the above.

⚠ Caution

Normally only set the ELE (elevator) switch to the up position and leave all other switches in the down position.

⚠ Caution

- If you change the radio frequency, be sure to use a frequency that is compatible with either a FM72MHz or FM40MHz band crystal by Futaba Corporation. (Only use the Hirobo genuine part for the flying unit crystal.)
If any other kind of crystal is used, it will not be possible to realize full operability and, even if operation is achieved, the arrival of radio signals will be unstable and it may cause the flying unit to crash.
- The FM72MHz and FM40MHz bands are not compatible with each other. Never use a FM40MHz crystal with a FM72MHz transmitter or flying unit, or a FM72MHz crystal with a FM40MHz transmitter or flying unit. Your flying unit will not work with either of these incorrect combinations.

Warning

- ⊘ The transmitter works with alkaline, manganese, NiCd, and oxyride batteries. Be sure to use eight batteries of the same kind.
 - ⊘ Do not use a combination of different kinds of dry batteries, such as alkaline, manganese, NiCd, oxyride, etc.
In addition to not being able to obtain the prescribed performance, there is the risk of burns from leaking battery fluid.
 - ⊘ Never wave the antenna of the transmitter around or put it close to peoples' faces, as there is a risk that the antenna tip could poke someone in the eye, etc.
 - ⊘ Never attempt to fly with the antenna of the transmitter not fully extended. If the transmitter is used while the antenna is not fully extended, the radio waves will not reach as far, and it could cause a crash.
 - ⊘ Never operate the on/off switch of the flying unit without ensuring that the battery level indicator of the transmitter lights up.
If the flying unit power is switched on while the transmitter is not functioning, there is a risk that unintended movement of the flying unit will occur.
 - ⊘ Never commence flying without first making sure that the transmitter's antenna is not loose.
If the antenna were to loosen and detach during flying, then no signal could be transmitted and the flying unit would crash.
 - ⊘ Never commence flying without first testing the transmitter.
- If even one error is present on the transmitter or the flying unit, the flying unit may crash.**
-

Caution

- ⊘ When inserting batteries into the transmitter, please make sure that the positive (+) and negative (-) ends of the batteries face in the correct direction. Mixing up the polarity will damage the transmitter.
 - ⊘ Never leave the battery inserted in the transmitter when the transmitter is not going to be used for an extended period. Remove the battery and store it in a place with low humidity.
If the battery is left in the transmitter, it could leak and reduce the performance and lifespan of the transmitter. If leaking does occur, be sure to completely wipe away all liquid from the case and terminal contacts.
 - ⊘ Never irresponsibly dispose of used dry batteries. Dispose of batteries as directed by your municipal government.
 - ⊘ Never remove the accessory crystal from the transmitter or the flying unit except when you change the frequency.
-



Do not fly the model with the transmitter antenna retracted.

The radio waves will not reach as far, and there is a risk of malfunctions.

If the S.R.B is operated with the transmitter antenna retracted, the radio waves will not reach as far, noise may get mixed with the signal, and there is a possibility of malfunctions.

When the transmitter antenna gets in the way of flight, such as for indoor flights, and you want to fly the model with the transmitter antenna retracted, retract the antenna a little at a time making sure that the radio waves are reaching the model, noise is not getting mixed with the signal, and that the model is not malfunctioning. Alternatively, fly the model with the model antenna extended.

Malfunctions may occur due to the structure of the room in which the model is being flown, or due to the influence of noise from electric appliances etc.

If noise is getting mixed in with the signal and malfunctions are occurring, fly the model with both the transmitter antenna and model antenna extended.

04 / Using the Control Unit

● Names and functions of the S.R.B SG control unit parts

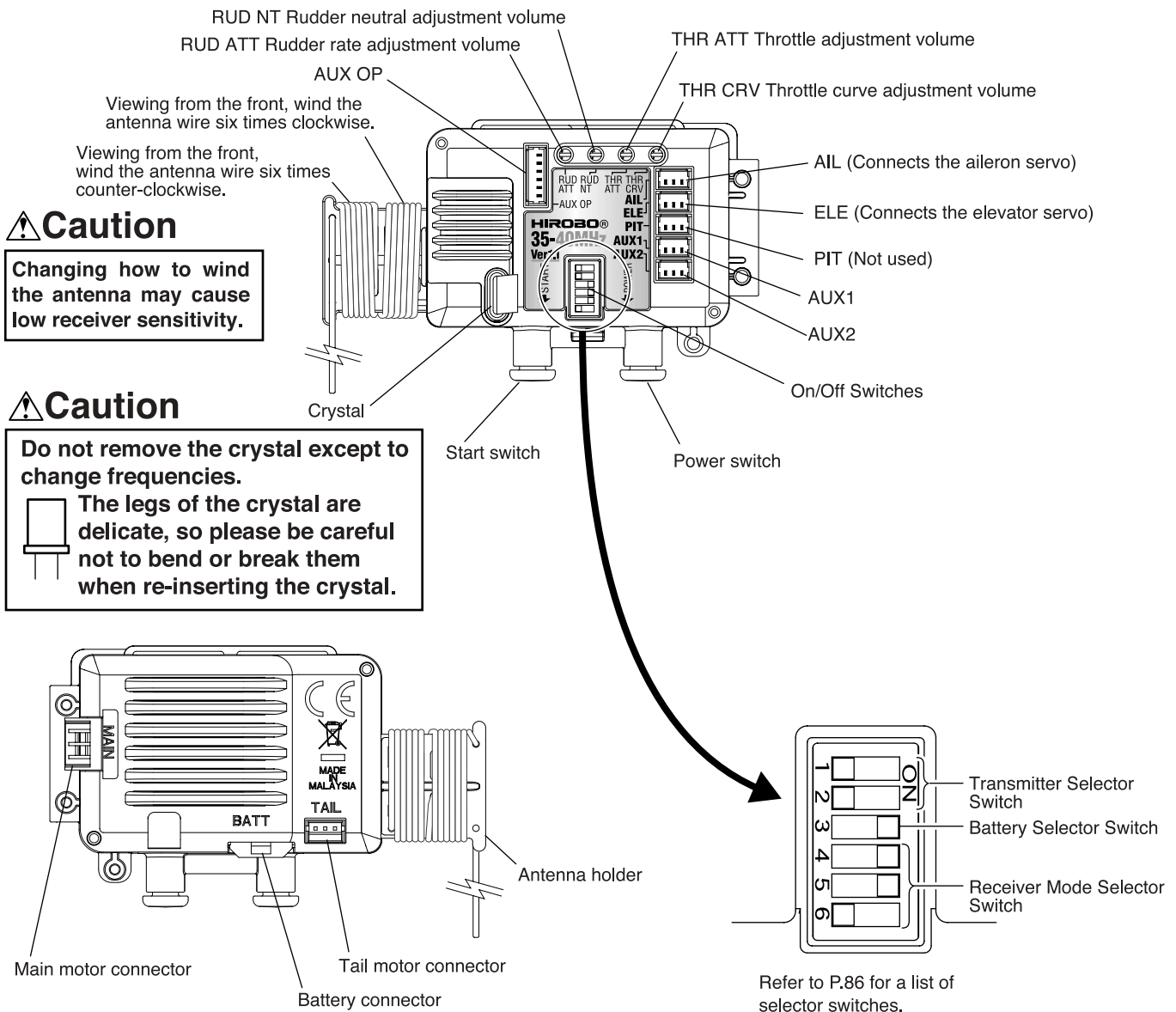

Set products without a programmable transmitter and kit products do not have receiver quartz crystal.

Please purchase the one appropriate for your unit.



* Please use genuine Hirobo quartz crystals only . (See P.75 for a parts list)

⚠ Caution

- ⊘ No not attempt to dismantle or modify the control unit. This may cause a malfunction.
- ⊘ Use only Hirobo-designated batteries.
- ⊘ Do not wrap the entire antenna wire around the antenna holder, and leave the excess wire free. Do not wrap it around the skid or the unit.
- ⊘ Never cut the antenna wire. Cutting the antenna wire will shorten the distance which the radio wave can reach.
- ⚠ Use only genuine Hirobo crystals.
- ⚠ The antenna on the control unit should also be fully extended.

05 / Image Training

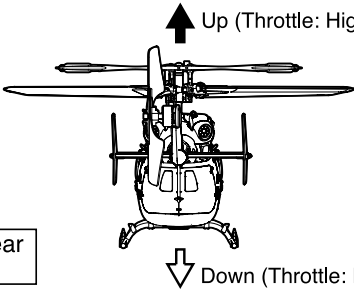
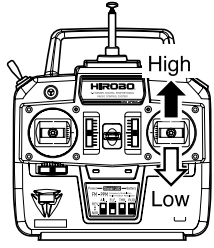
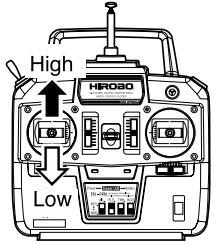
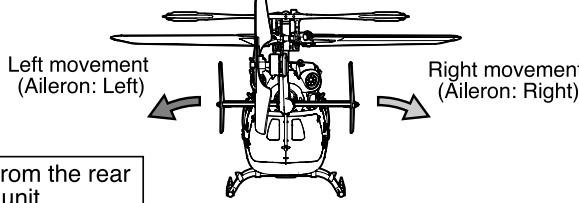
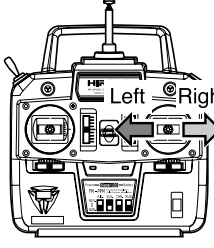
Thoroughly learn helicopter movement and stick operation from the following table.

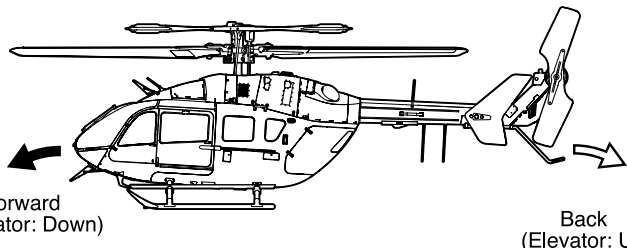
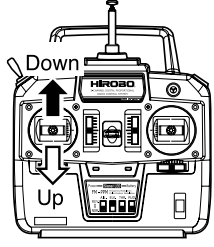
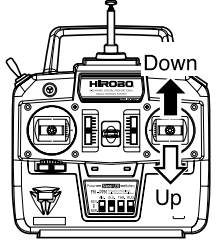
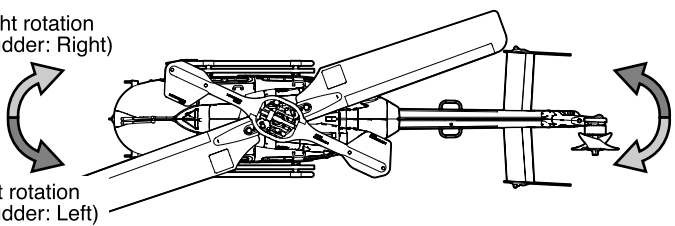
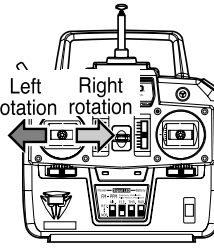
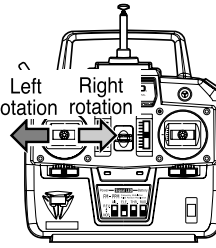
Operation	Unit movement	Mode I	Mode II
Throttle	 <p>View from the rear of the unit</p>	<p>(Throttle)</p> 	
Aileron	 <p>View from the rear of the unit</p>	<p>(Aileron)</p> 	
Elevator	 <p>View from the side of the unit</p>	<p>(Elevator)</p> 	
Rudder	 <p>View from the top of the unit</p>	<p>(Rudder)</p> 	

Before beginning flight practice, make sure to learn how to control with the chart above.

* When we speak of the “up” or “down” operation of the elevators, this does not refer to moving the stick up and down, but rather moving the nose up or down. If you think of a steering rod, it will be easier to picture this.

⚠ Caution

During a flight, be sure to always keep your fingers on the transmitter's sticks. Continuous operation of the controls is required for RC helicopters, and therefore attempting to operate the flying unit without your fingers on the transmitter stick increases the chance of incorrect operation or a crash.

Point

- In operating the transmitter, the flying unit moves in proportion to how much and how long you tilt a stick. Therefore, be sure to move the stick slowly, little by little. A quick, large move of the stick makes the flying unit unstable, resulting in a crash. While you are a beginner practicing how to fly an XRB, try to move the stick 1 mm by 1 mm.
- A helicopter does not move downward on its own power. By adjusting its ascending force, the helicopter ascends, hovers, and descends in balance with gravity. If you bring down the throttle stick abruptly while the flying unit is in the air, the flying unit simply falls due to gravity resulting in a crash. To make the unit descend, be sure to bring down the throttle stick slowly little by little. When the unit begins to descend, leave the throttle stick as it is and wait until the unit touches down. At the moment of touchdown, bring the throttle stick down to its lowest position.

06 / Body Assembly

IMPORTANT!

Some parts require painting before assembly so read through the instructions before assembling and verify the assembly and painting order.

For those who purchased a full set (or a set without the programmable transmitter) with the pre-painted body, see pages 19-21 and 43-47.

Assemble and paint procedures (Example)

Refer to pages 22-34 for detailed painting and decal application methods.

■ SÉCURITÉ CIVILE

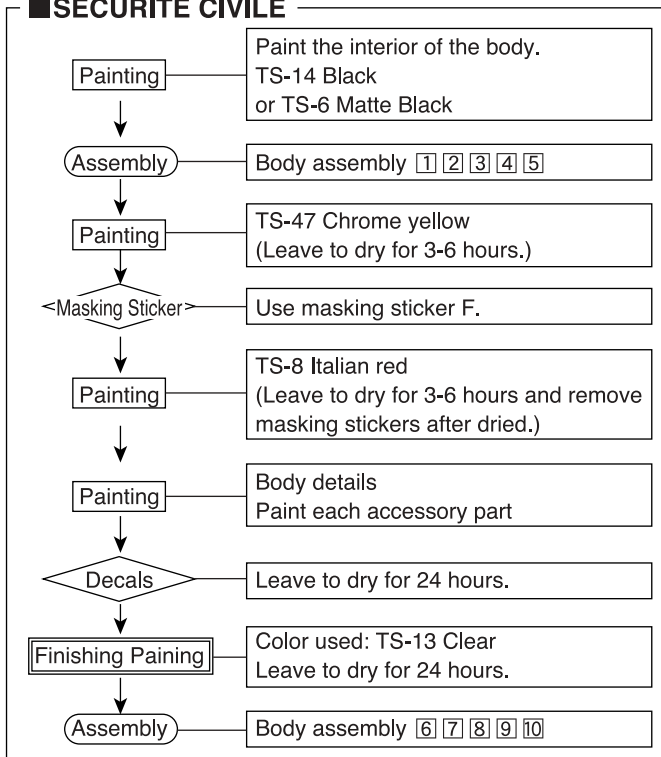

■ REGA

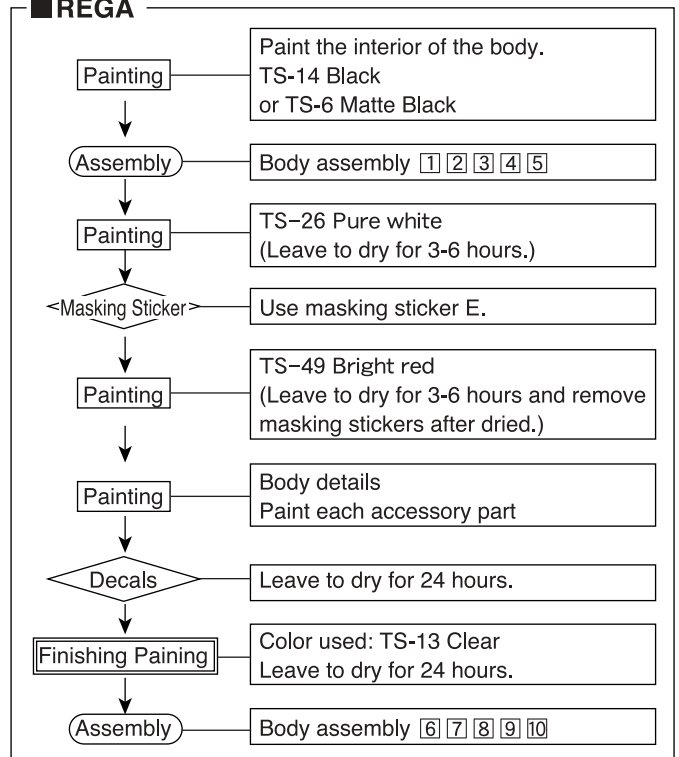

■ HESSEN POLIZEI

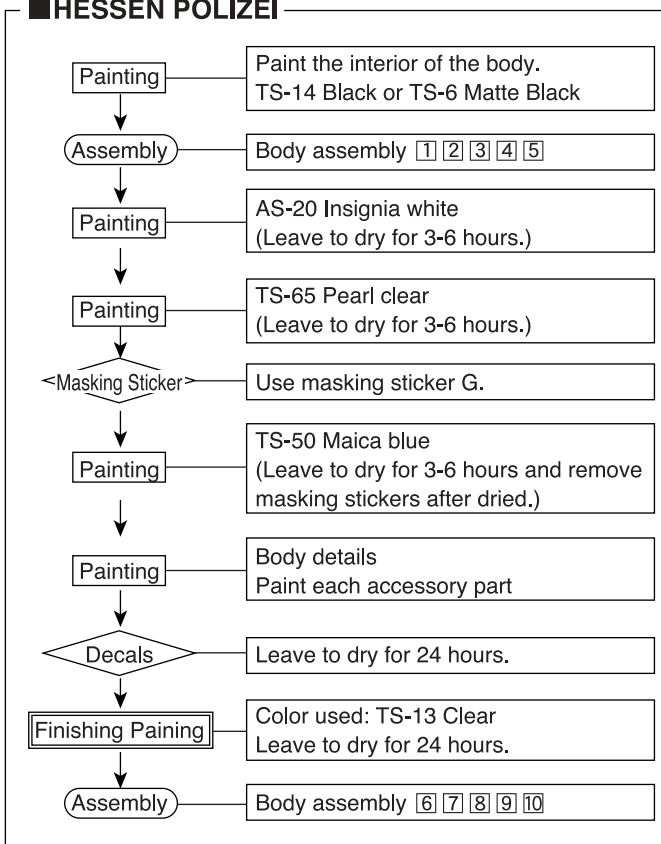

【About body interior painting】

Painting the body interior, which can be seen through the windows, before assembly will make for a more attractive finished product.

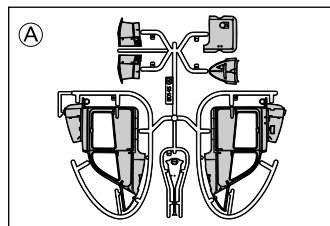

Painting the interior of the hatched parts in A, B and C is recommended. Carry out painting after masking the surface and adhesive surface so no paint gets on them.

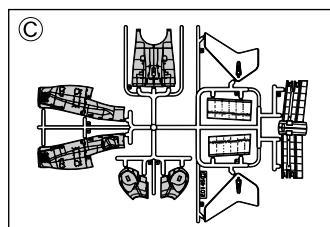
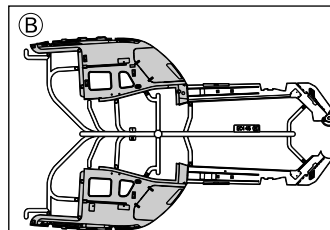

Before assembly

There are many parts for S.R.B such as screws and $\phi 4$ balls. We recommend you to use a tray to keep them in during assembly. Using a magnet is also a good idea to keep the screws in one place.

Use Tamiya Epoxy adhesive on places designated with these icons.

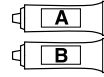

Use Tamiya Cement (plastic model adhesive) on places designated with these icons.



Point How to fasten tapping screws

The S.R.B uses a large number of tapping screws. There is a trick to tightening the screws properly, so please read the following section carefully.

Tapping screws cut threads in the holes of the parts. When screws are difficult to tighten, fasten the screw until the part is properly set. However, do not over-tighten the screw to the point of stripping the threads or warping the part.

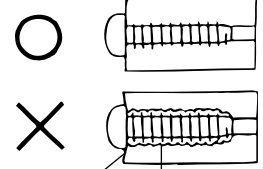

Over-tightened. Stripped threads.

1. Rear body assembly

Point

Attach **D-29** on the SÉCURITÉ CIVILE and Rega.

The holes are not cut out for **D-29**, so use a cutter or file to cut out the holes before using adhesive to connect the left and right sides.

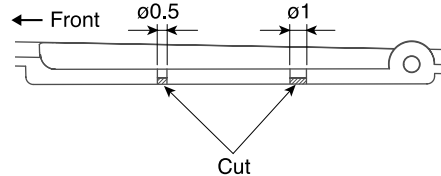

* Attach **D-29** afterwards.

- M1.4X4TS 1
- Magnet 4X3 2

Caution

Attach after checking magnet polarity.

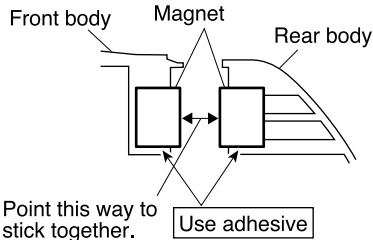

Point this way to stick together.

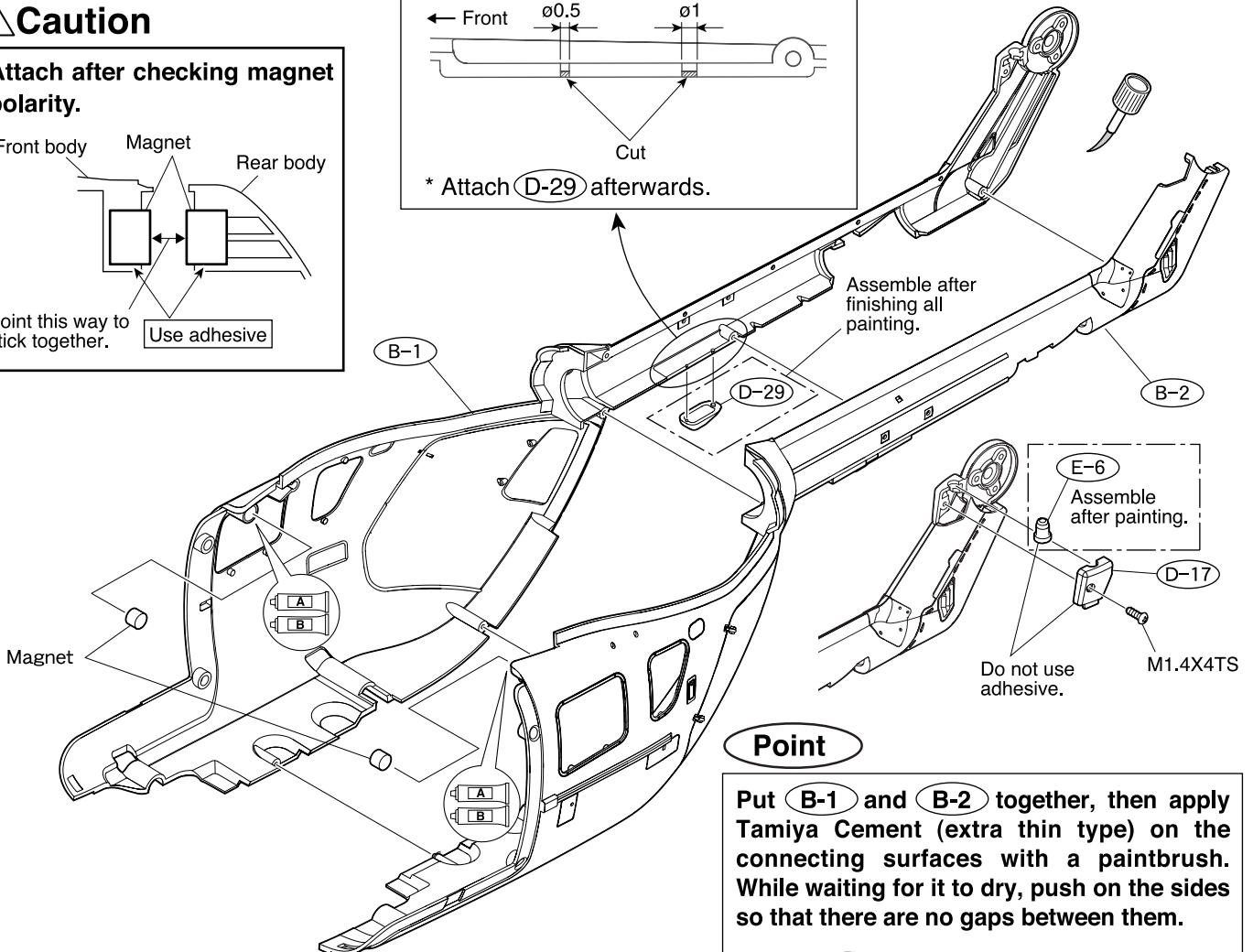

Point

Put **B-1** and **B-2** together, then apply Tamiya Cement (extra thin type) on the connecting surfaces with a paintbrush. While waiting for it to dry, push the sides so that there are no gaps between them.

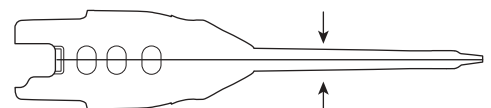

2. Top cover installation

Attach in numerical order from (C1) to (C5).

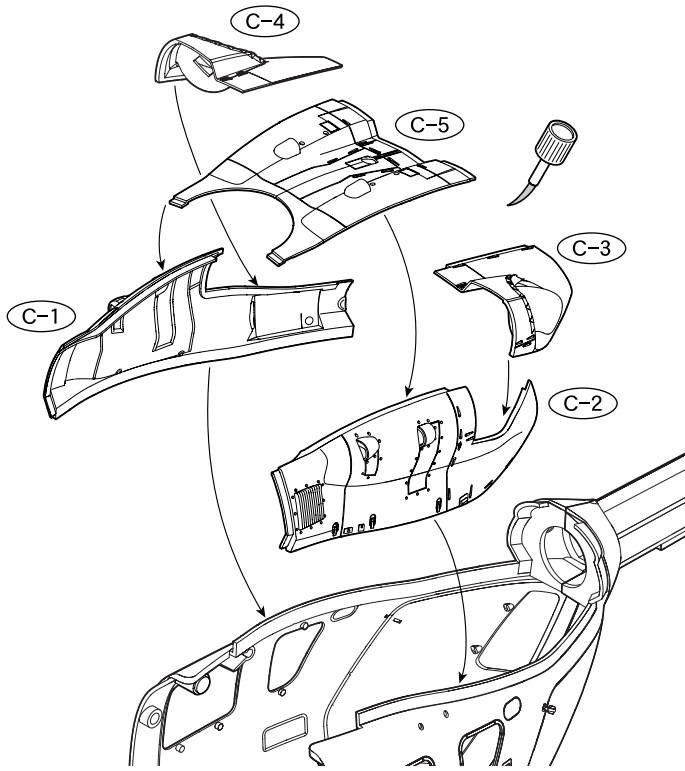

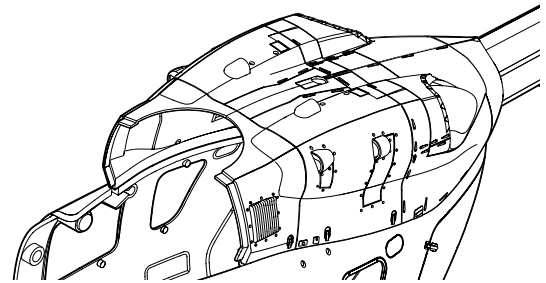
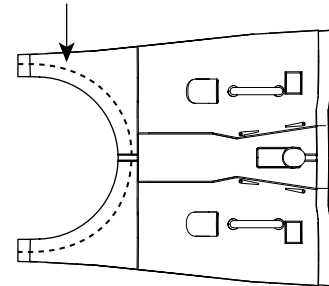

Point

If equipping the S.R.B Quark SG, before assembly and painting use a cutter or other tool to cut along the line on the inside of (C-5) as shown in the figure below.



3. Front body assembly

 Magnet 4X3 2

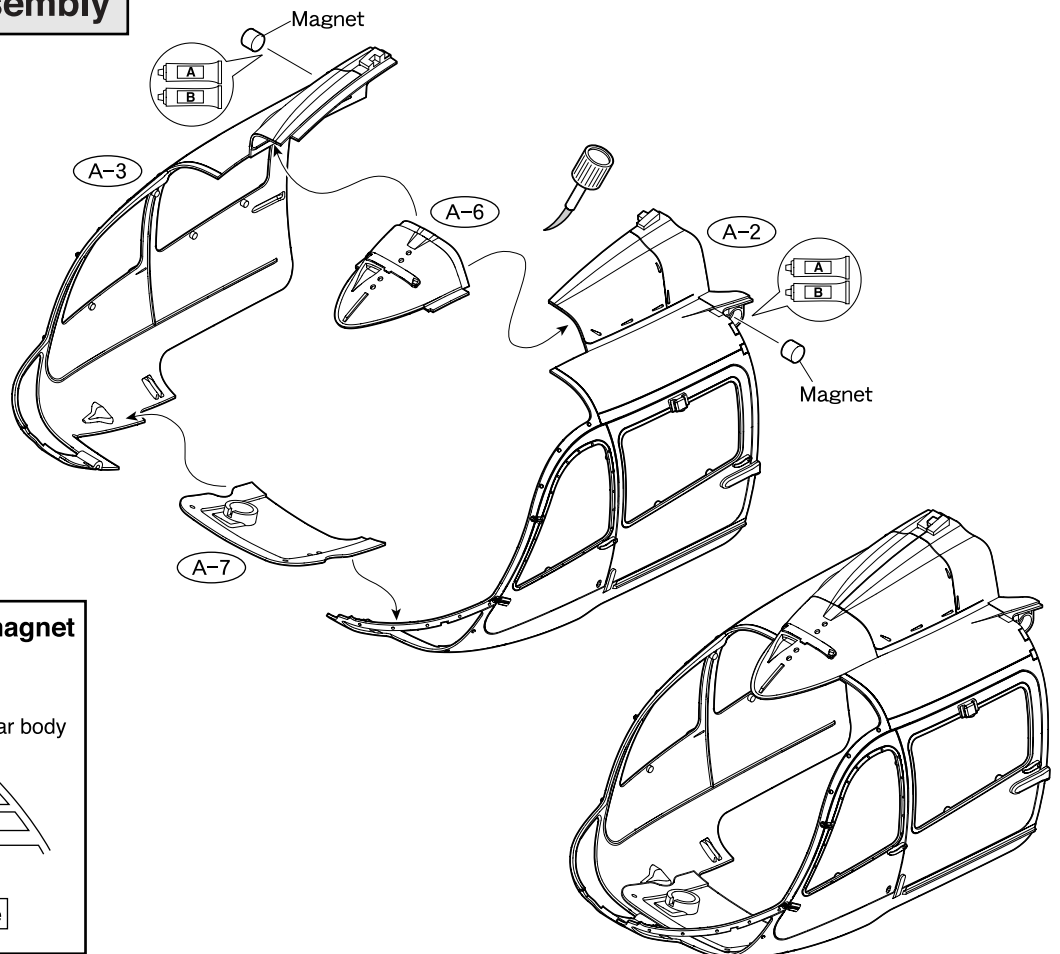

⚠ Caution

Attach after checking magnet polarity.

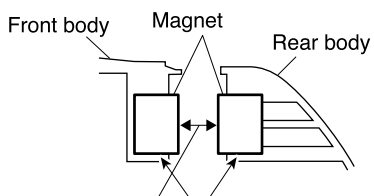

Point this way to stick together. Use adhesive

4. Horizontal fin assembly

⊕ 
 M1.4X5TS 4

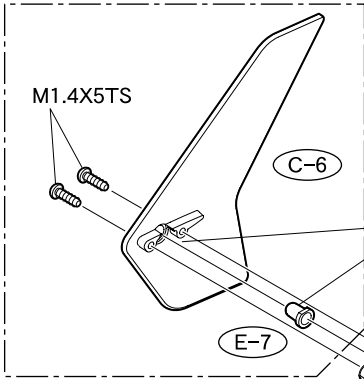

Assemble after finishing all painting.

Caution
 Do not use adhesive.

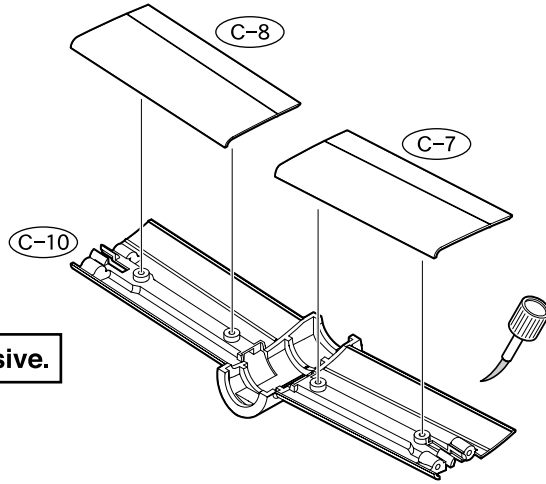

Caution
 Do not use adhesive.

Assemble after finishing all painting.

You can replace with optional LEDs on **E-6** and **E-7**. Do not use adhesive if you are considering this replacement.

Point

Attach **E-7** with the flat part pointing up.

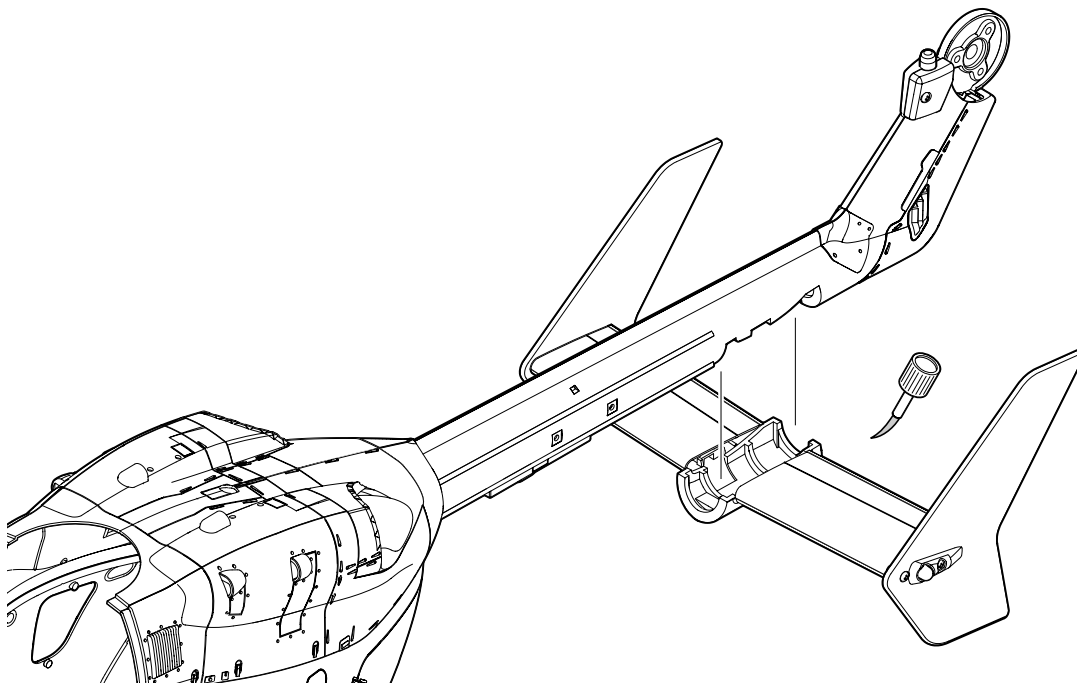
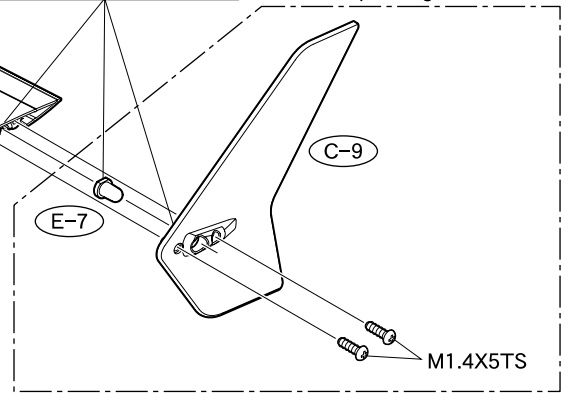
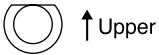

5. Front top cover assembly

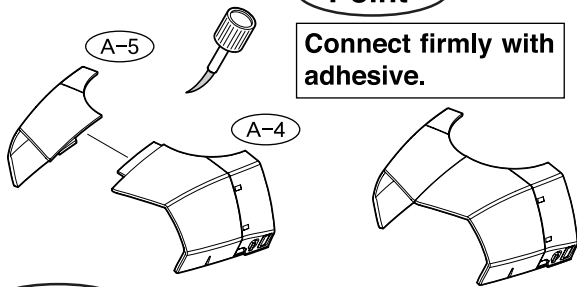

Point

If equipping the S.R.B Quark SG, before assembly and painting use a cutter or other tool to cut along the line on the inside of **A-5** and **A-4** as shown in the figure below.

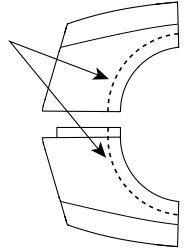

Point

Paint the body and antennas after assembling up to this point. See pages 22-34 for details on how to paint.

6. Front top cover and front body installation

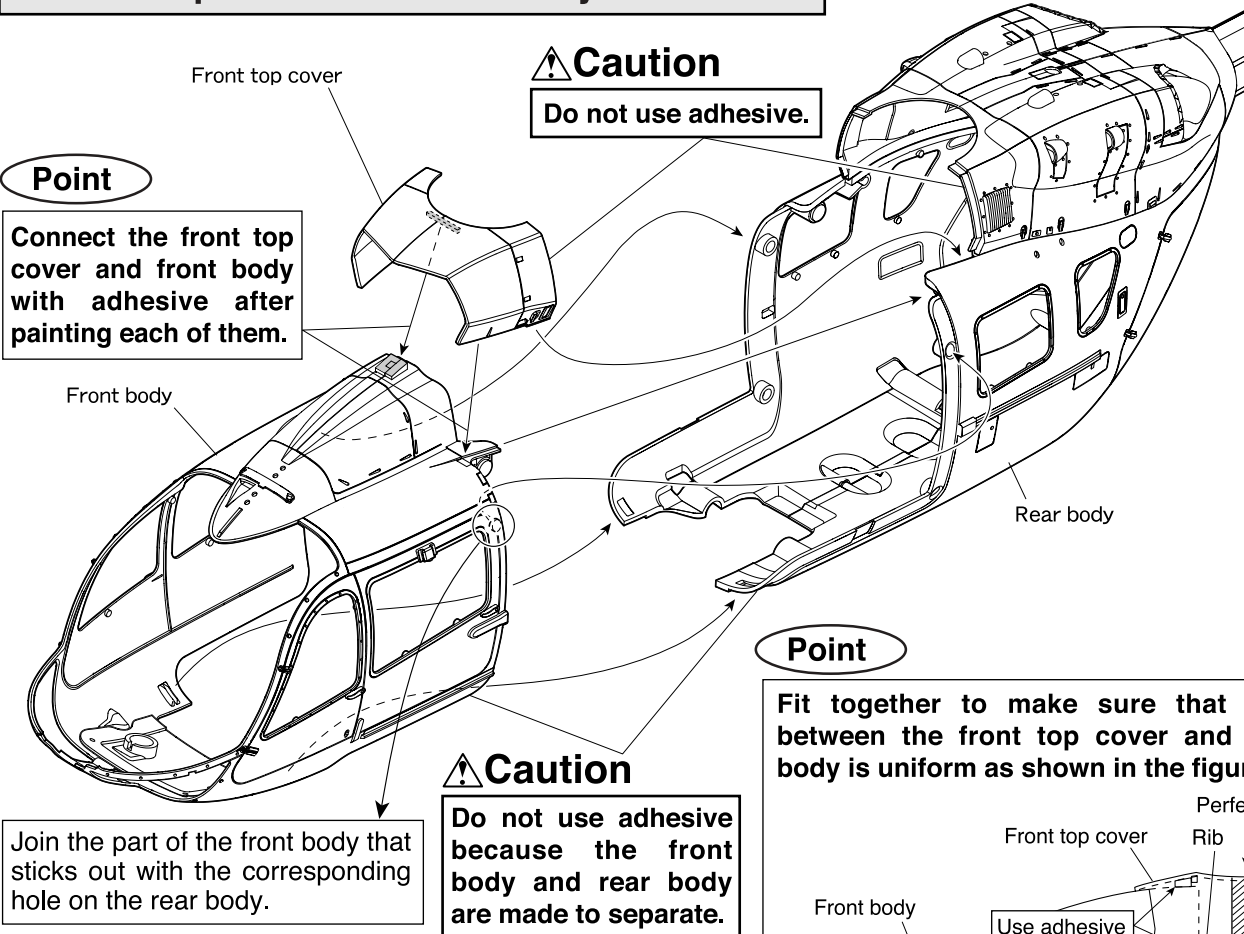

Point

Fit together to make sure that the gap between the front top cover and the rear body is uniform as shown in the figure below.

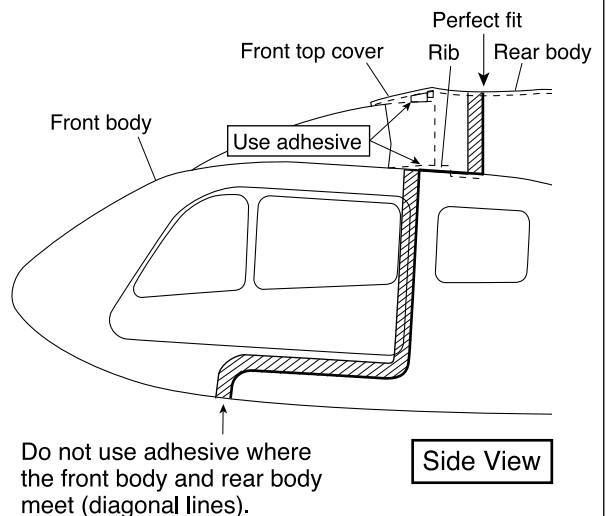

How to Take Apart

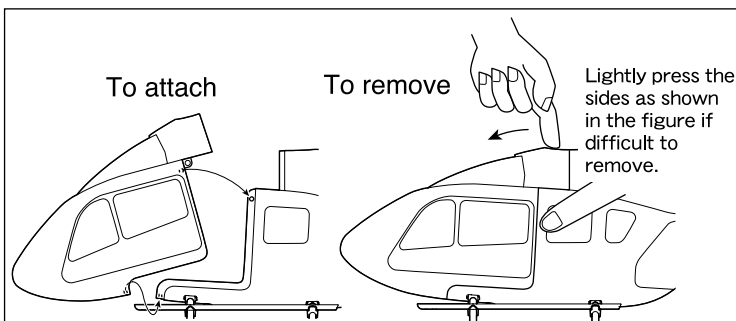

7. Windows installation

Point

The window parts will adhere well if you use Tamiya Cement (pouring type). When adhering painted parts together, use Tamiya Finishing Paper to remove paint from the connecting surfaces.

Point

Attach the window parts after applying clear coat paint on the body.

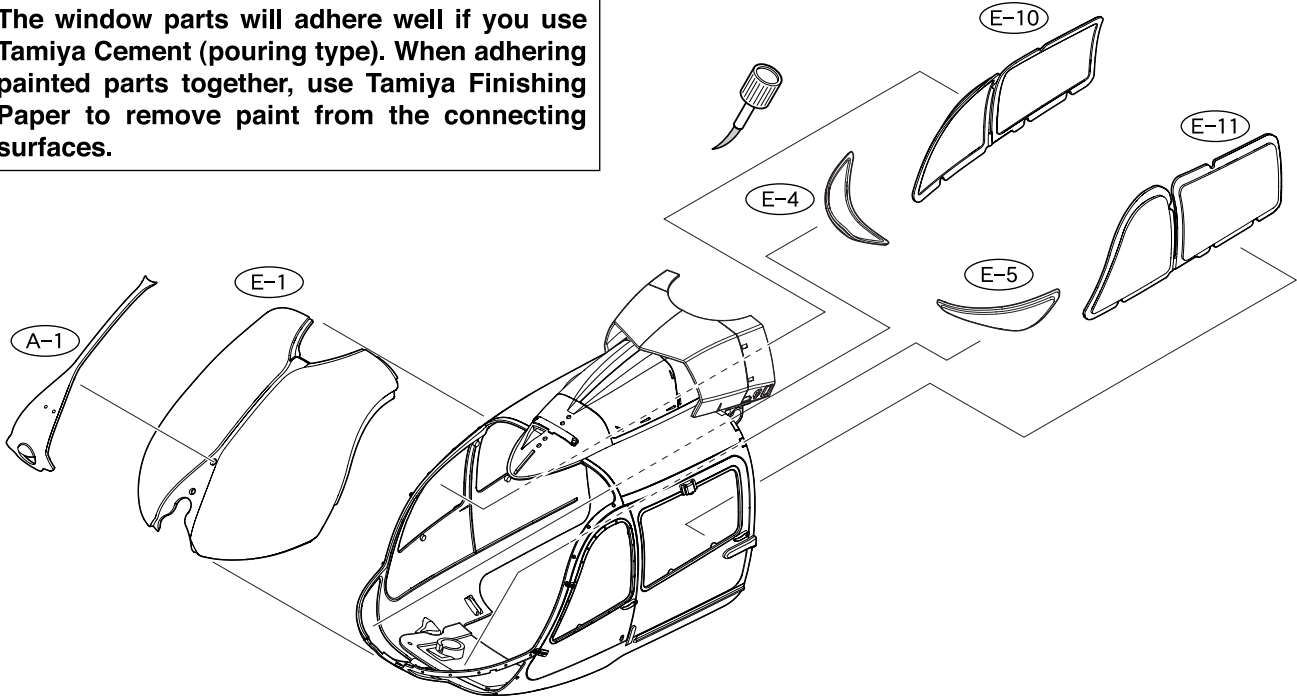

Insert the (E-1) front window into the front body from the outside. Insert other windows from the inside.

Fit the indentations in the windows with the bumps on the body when attaching the windows.

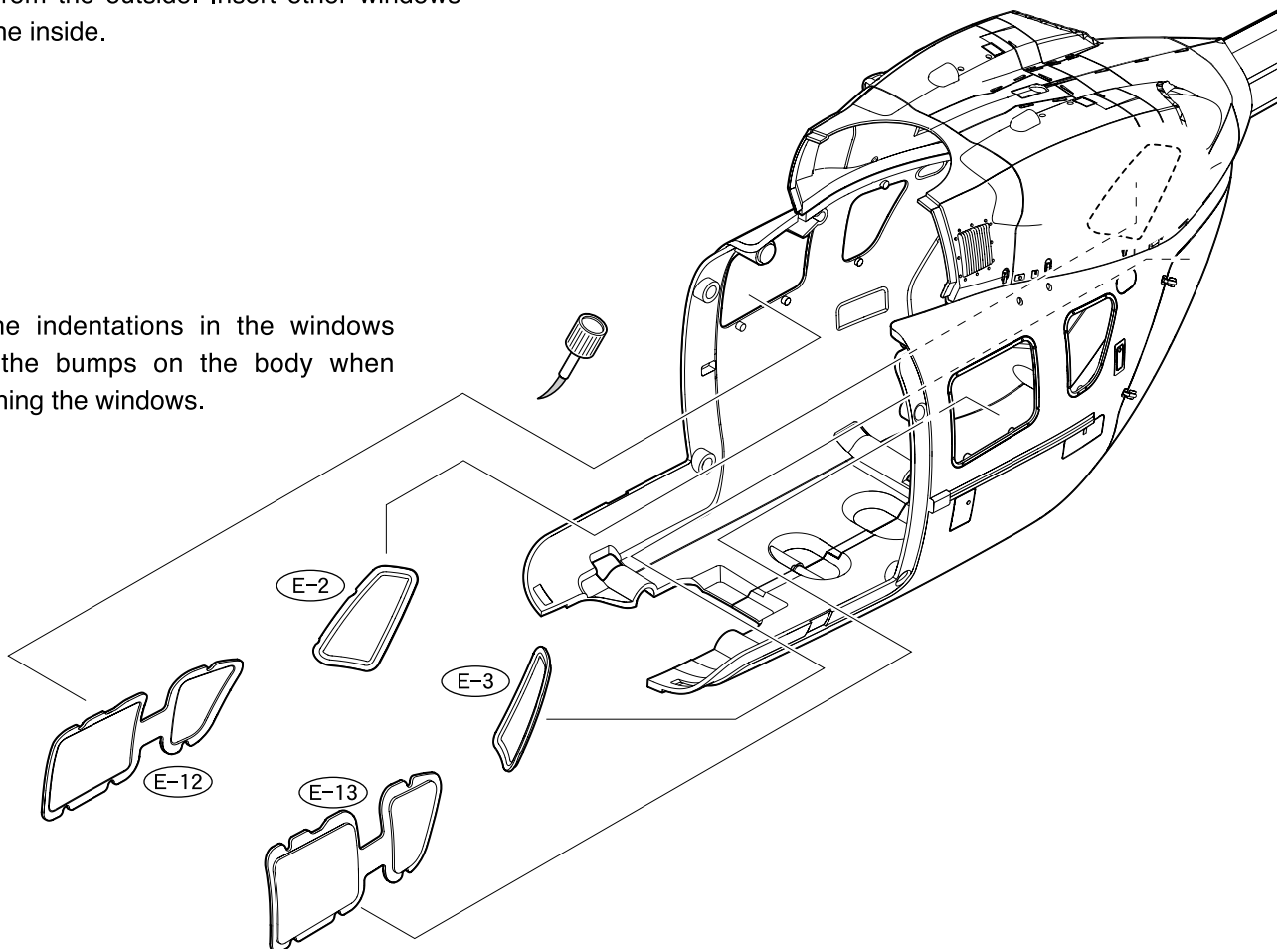

8. Accessories installation

For those who purchased a full set (or a set without the programmable transmitter) with the pre-painted body, attach accessories such as antennas by following the procedure specified here.



M1.4X4TS 1

Point

Attach accessory parts after painting the body. We recommend using a very strong epoxy adhesive when attaching accessory parts.

For the REGA and POLIZEI

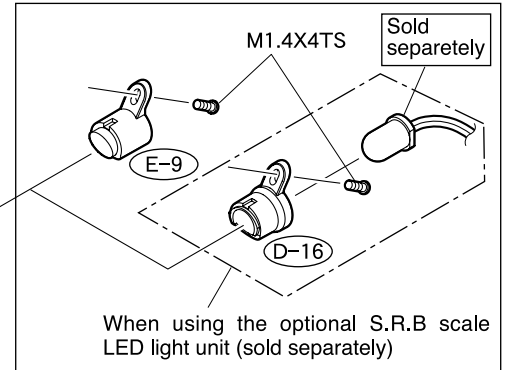

Point

Pay attention to the direction of **D-6** and **D-7** when installing. The protrusions should point down.

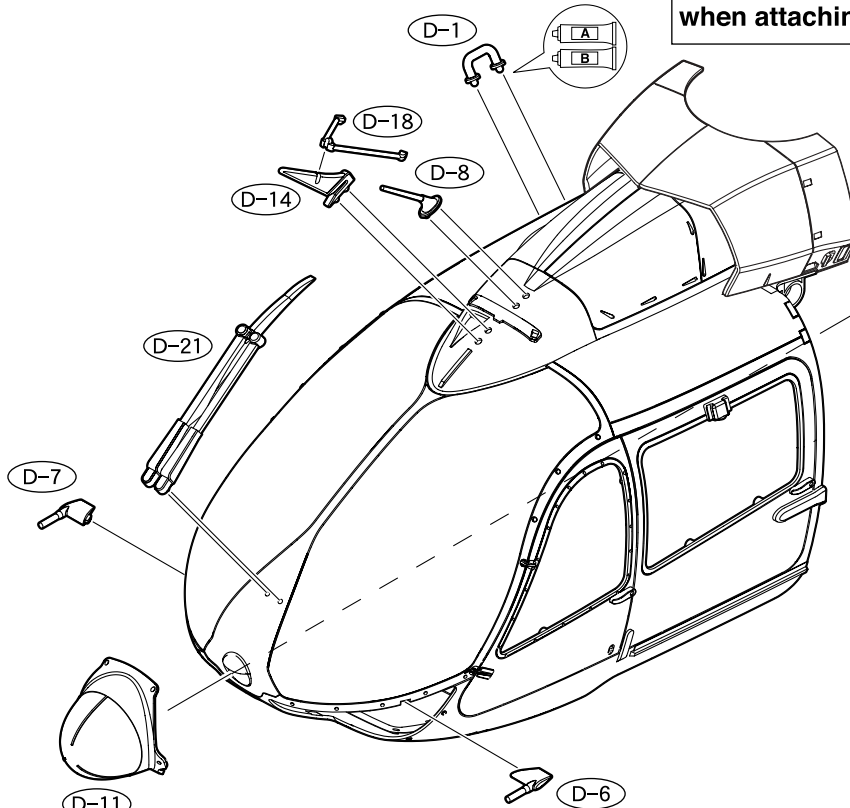
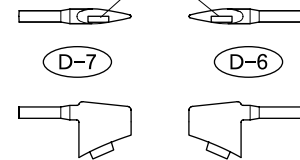

D-11

(Only attach to SÉCURITÉ CIVILE)

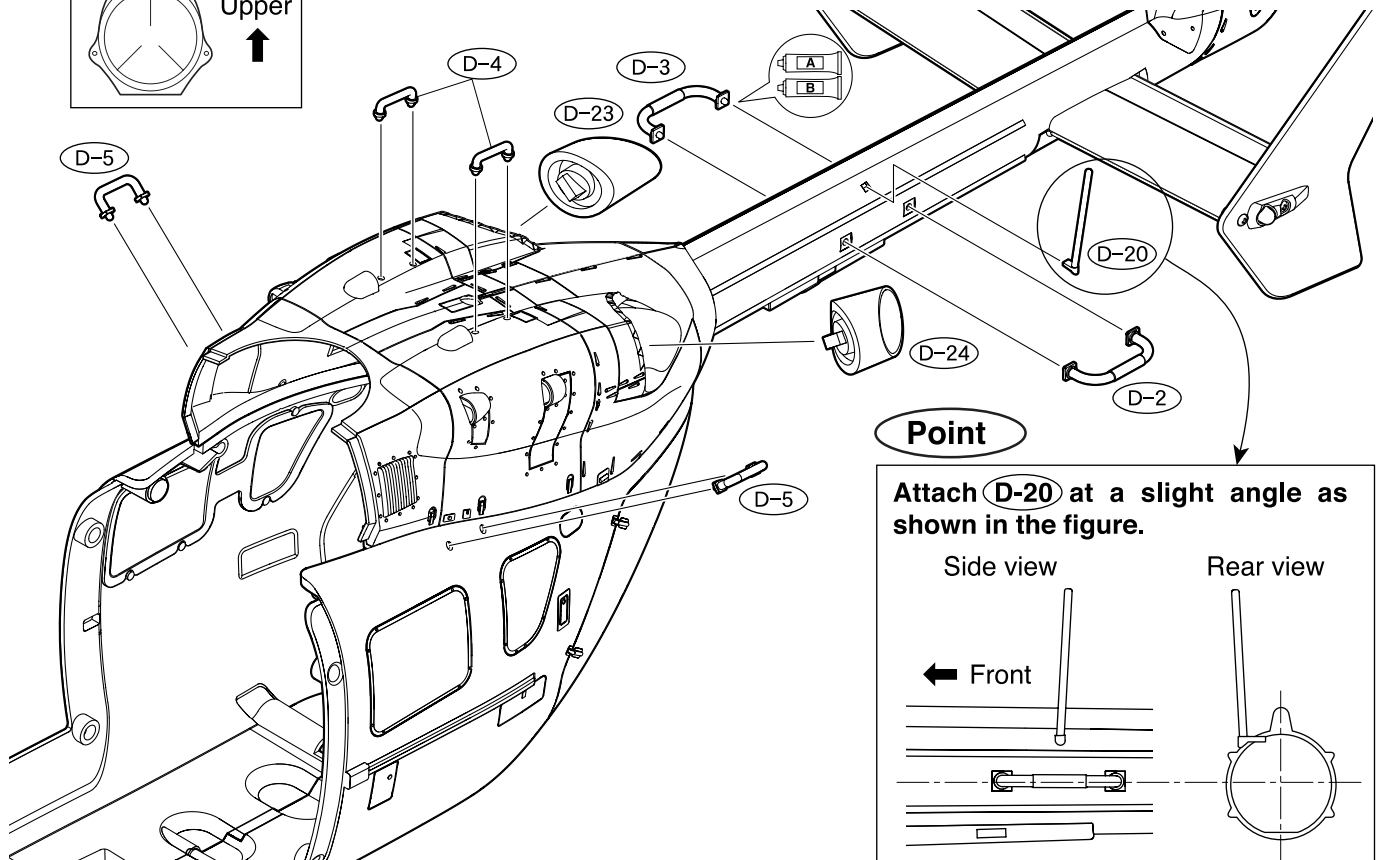
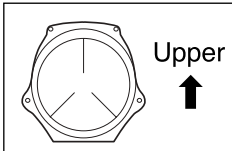

Point

Attach **D-20** at a slight angle as shown in the figure.

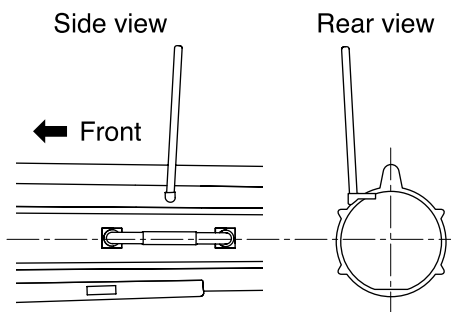

9. Accessories installation

Point

Attach accessory parts after painting the body. We recommend using a very strong epoxy adhesive when attaching accessory parts.

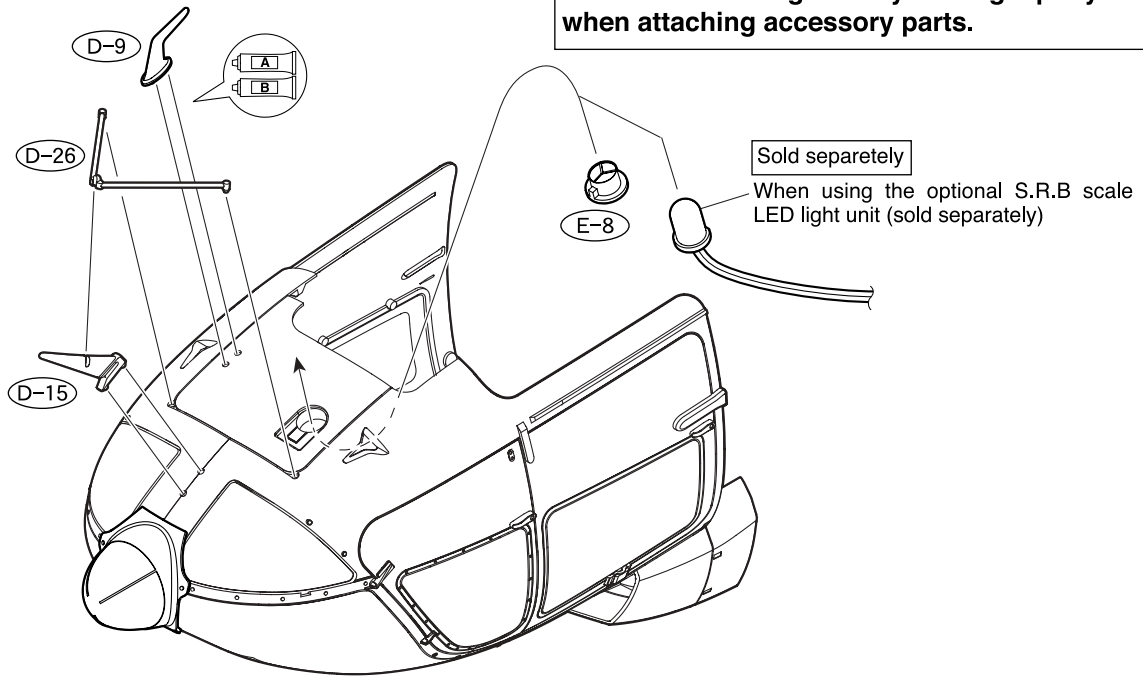

Point

Pay attention to the angle at which you attach.

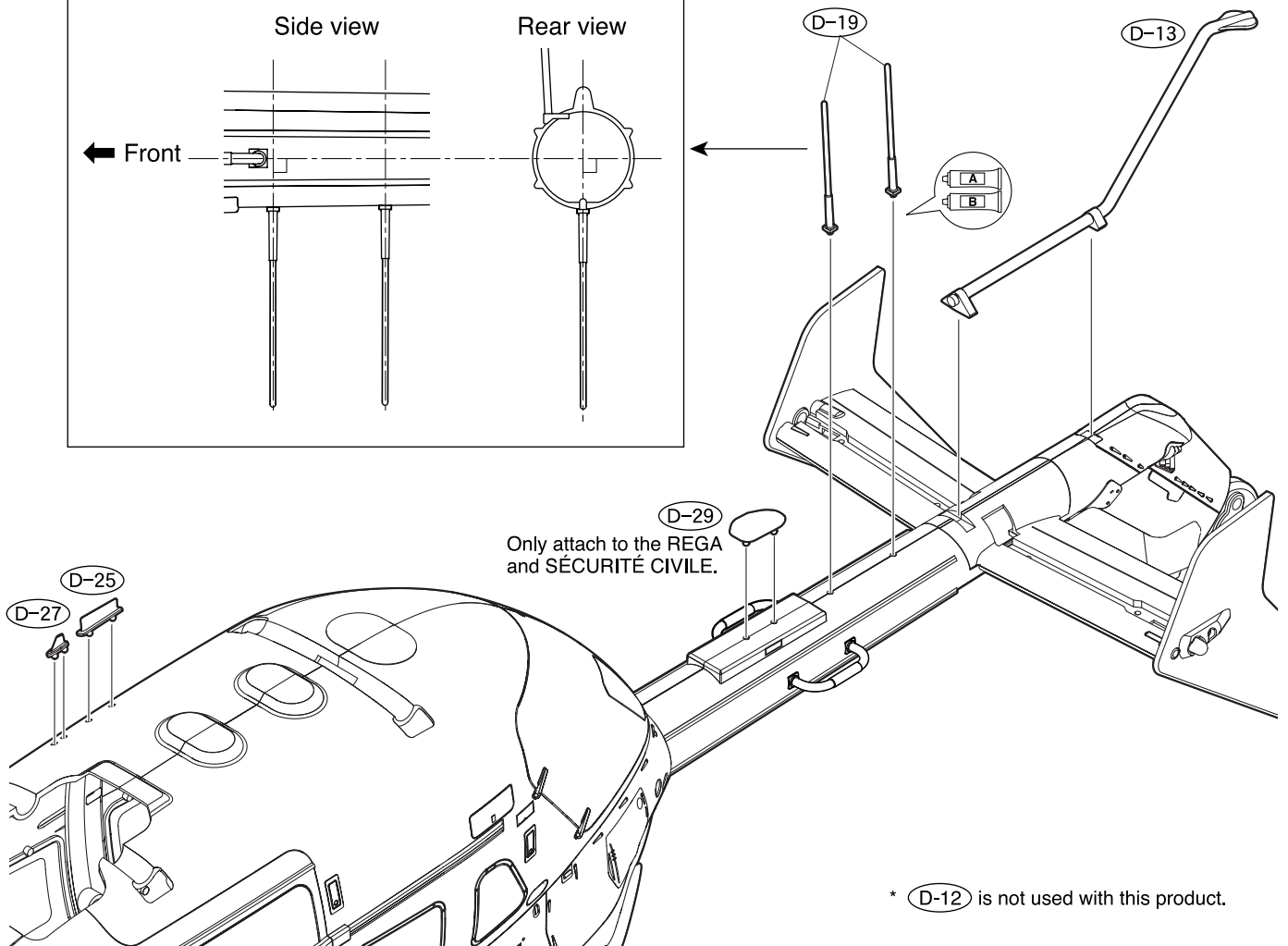
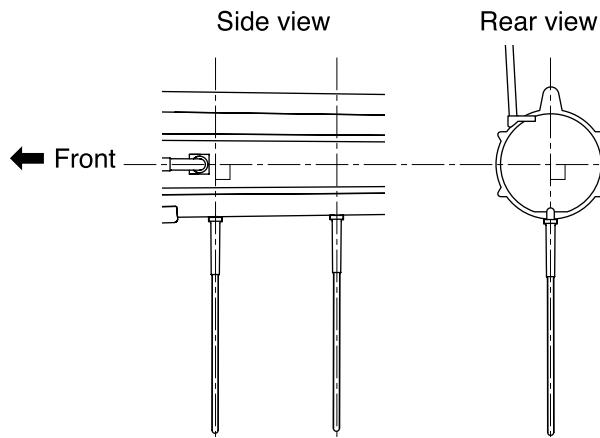

10. Skid installation

⊕ 
M1.4X3TS 6

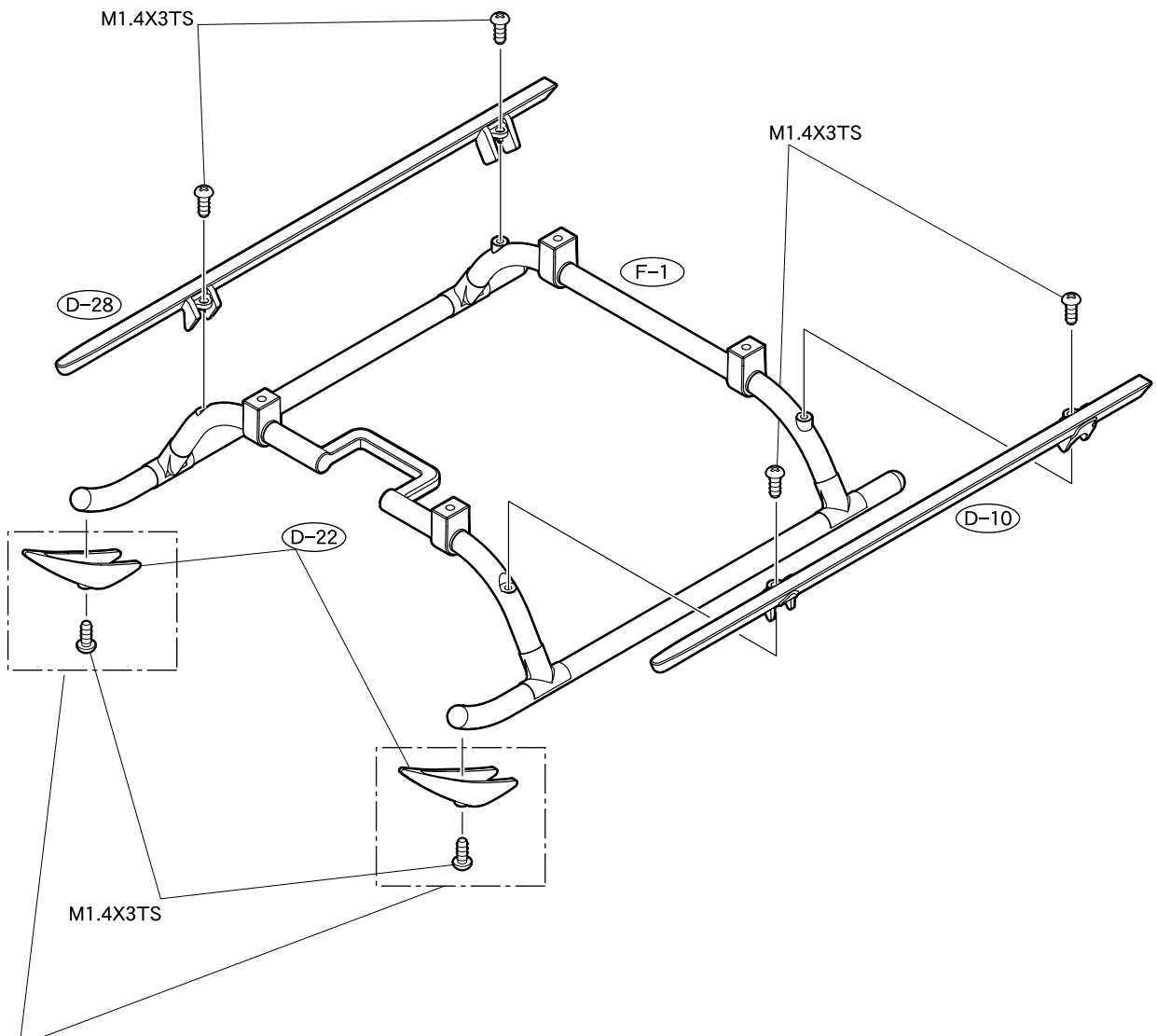

Do not attach to the POLIZEI.

Point

Cut the shaded section of **D-22** with a cutter or other tool.

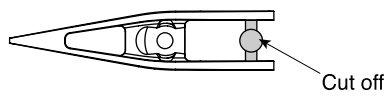

07 / Body Paint / Applying Decals

● Handling Decals

Decals are stickers that are used with water to transfer images onto plastic models. They can realistically create complex graphics and lettering because they are thinner and stick to parts better than normal stickers.

● Required Tools

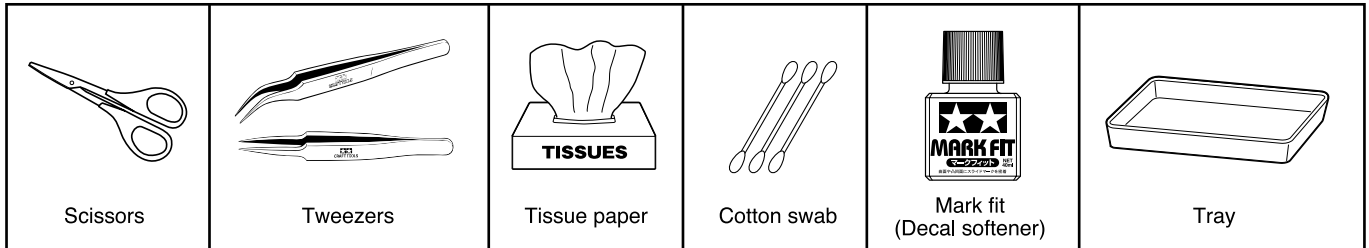

● How to Apply

- ① Cut out pieces of backing paper large enough for each decal.
- ② Submerge the decals you cut out on each piece of backing paper for 10 to 20 seconds in a tray containing a shallow amount of water.

⚠ Caution

Do not leave the decals submerged in water any longer than instructed. The adhesive glue on the film will melt into the water and make the decals adhere poorly.

- ③ It is okay if a decal moves about on top of the backing paper when you lightly touch it with your finger.
- ④ Take each piece of backing paper and decal to the location you want to place the decal and slide the decal onto the body.

⚠ Caution

Do not handle directly with your fingers. The decals will fold or get rolled up and cause problems. Use tweezers for small decals.

- ⑤ Be careful when changing a decal's position. Pushing too hard can tear it. To change position, drip some water on top of the decal and then move the entire decal together.
- ⑥ When you've finished moving the decal, press it softly with a tissue to soak up the excess water.
- ⑦ It is difficult to affix decals to bumpy parts. For these parts, rub Mark Fit (a decal softener) on top of the decal and let sit for about 30 seconds, then gently press the decal into place with a cotton swab.
- ⑧ Let the decals sit for at least 24 hours to completely dry them.

⚠ Caution

Decals that have not completely dried may tear easily, and melt or wrinkle when clear overcoat is applied.

● Applying Masking Stickers

SÉCURITÉ CIVILE

Use Masking Sticker F supplied with this product. Apply each numbered sticker by referring to the figures below.

Point

Test out how the front body, rear body and front top cover fit together, then apply the masking stickers. Paint the front body, rear body and front top cover separately. You cannot paint these parts well if you leave them joined together.

Point

- Apply after letting the TS-47 Chrome yellow paint dry for 3 to 6 hours.
- Apply masking stickers firmly so that no air gets underneath and the borders between paint look good.

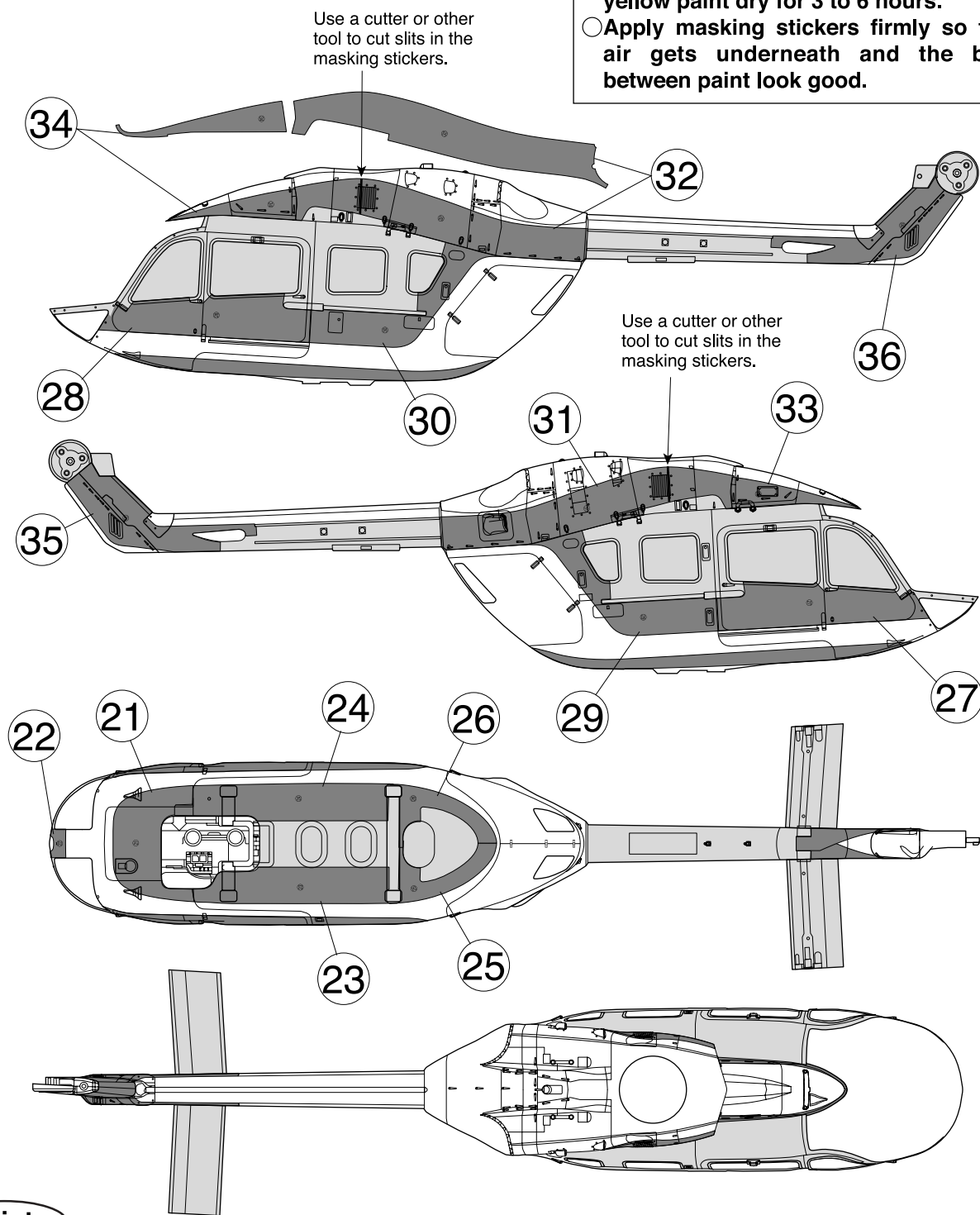

Point

Cover the windows from the inside so that no paint gets inside the body when painting. Cover the areas with masking tape.

Vertical fin

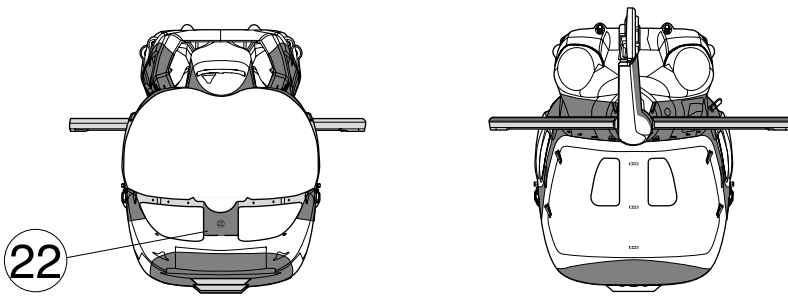
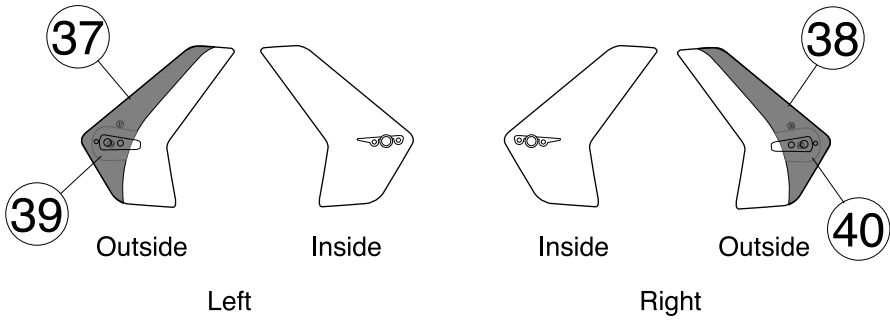

Front window

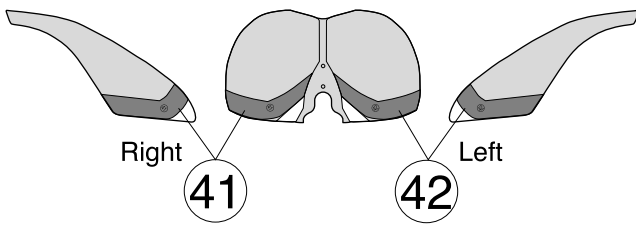

Masking seal F

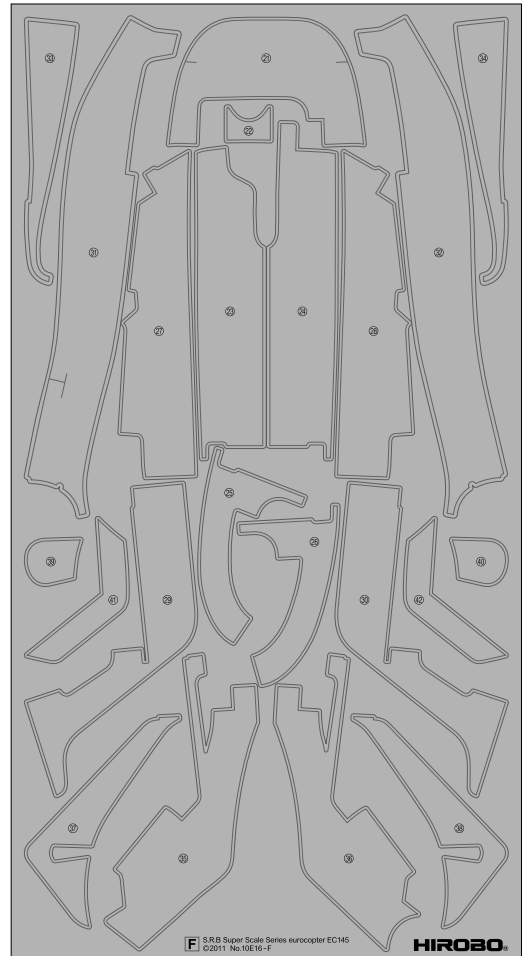

SÉCURITÉ CIVILE

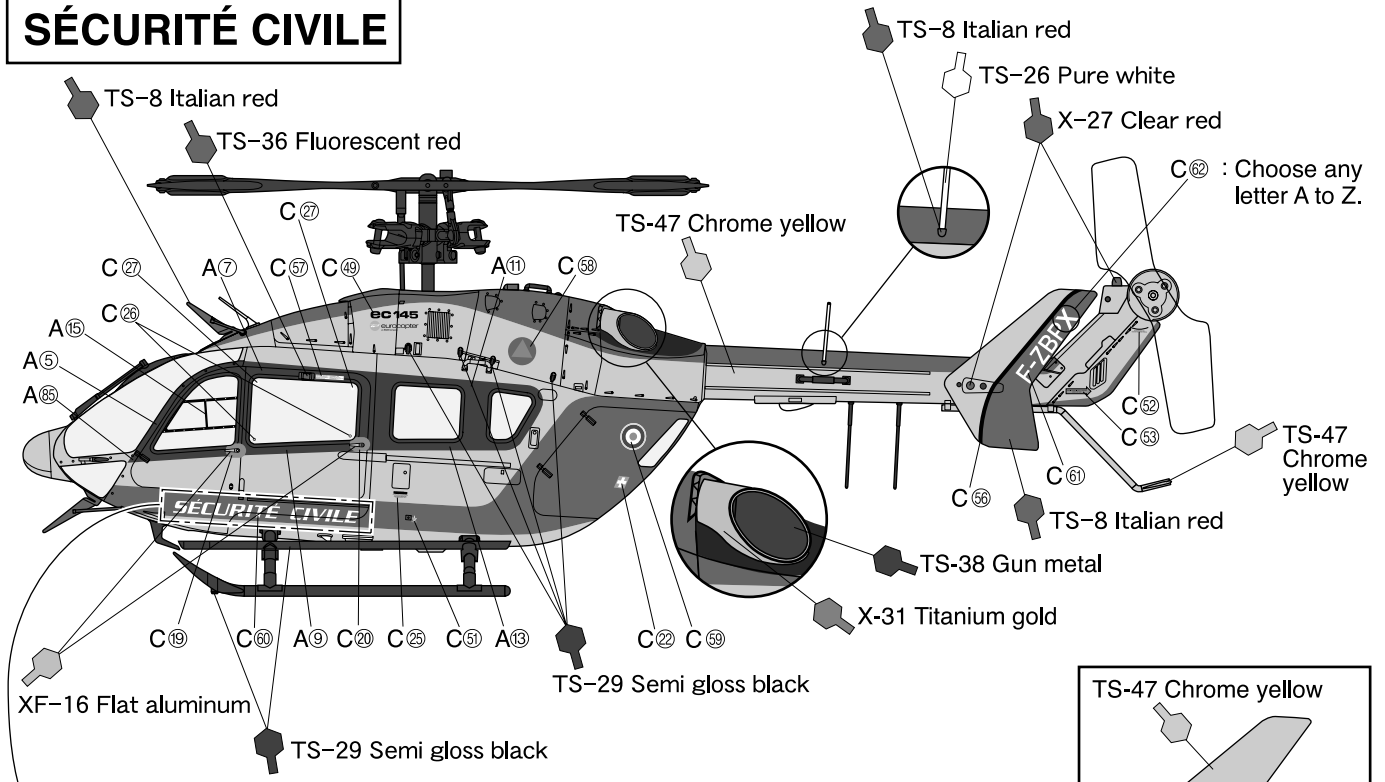





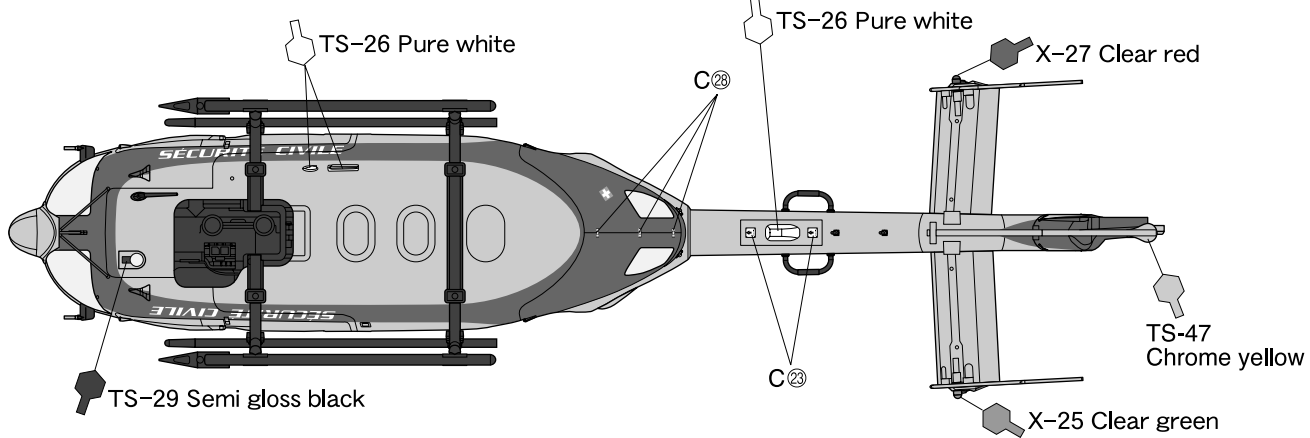
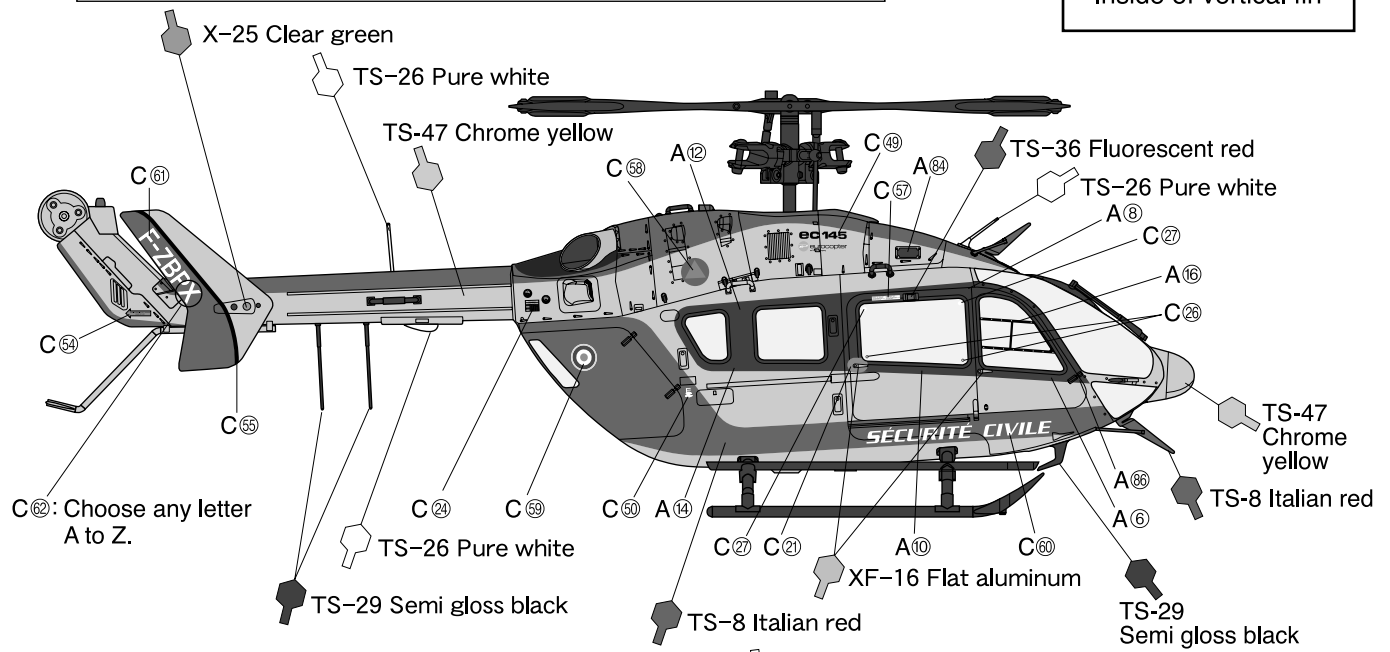
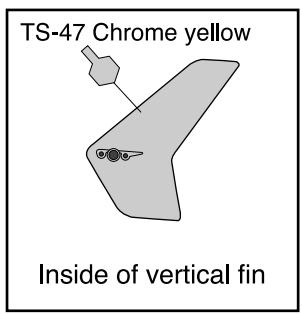

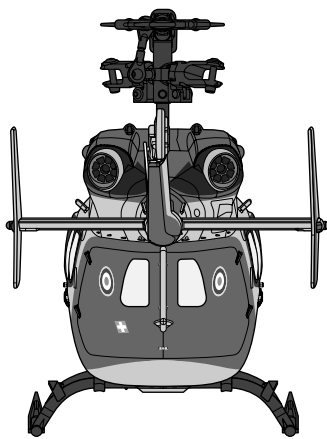
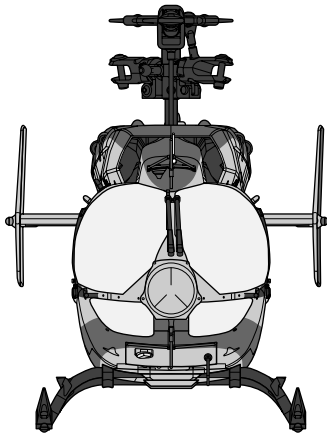





← **SÉCURITÉ CIVILE** ←

After applying decals, cut along the lines between body parts with a cutter or other tool.





-  TS-8 ● Italian red
-  TS-47 ● Chrome yellow
-  TS-29 ● Semi gloss black
-  TS-38 ● Gun metal
-  TS-26 ● Pure white
-  TS-36 ● Fluorescent red
-  TS-13 ● Clear * Use as finishing coat.
(See page 13.)
-  X-31 ● Titanium gold
-  X-25 ● Clear green
-  X-27 ● Clear red
-  XF-16 ● Flat aluminum

 This mark denotes numbers for Tamiya Paint colors.

Point

Tamiya Colors designated with the TS symbol are for Tamiya Color spray cans. X and XF represent Tamiya Acrylic Paint or Tamiya Enamel Paint.

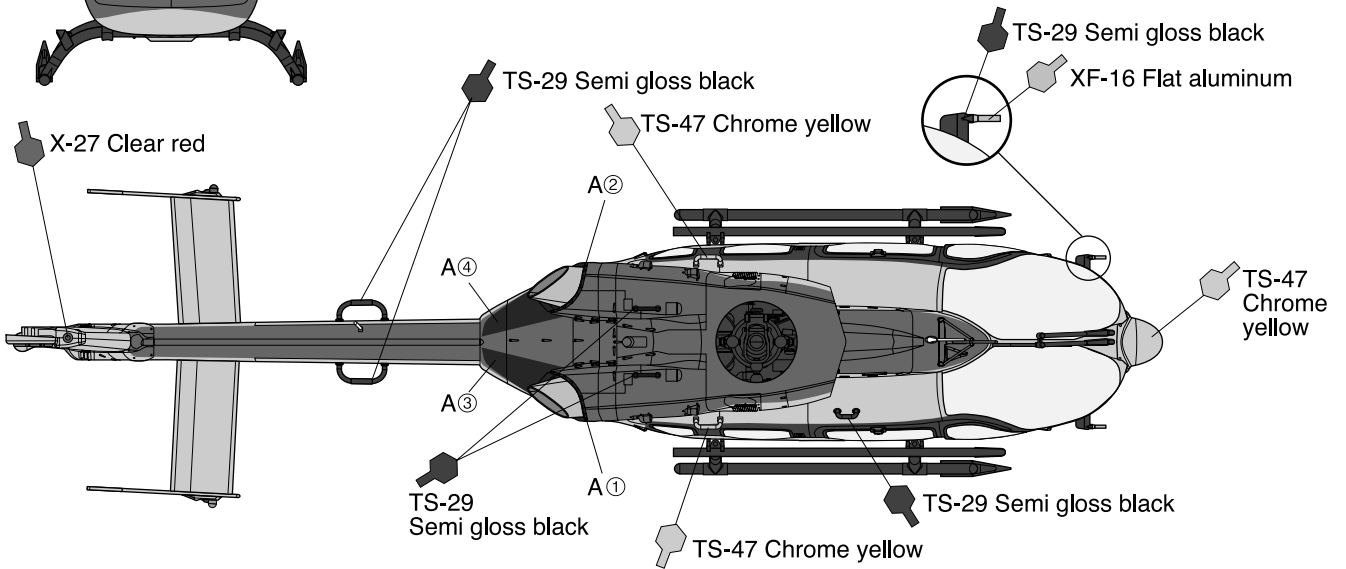

Decal A (Window frame decal is the same for all 3 models.)

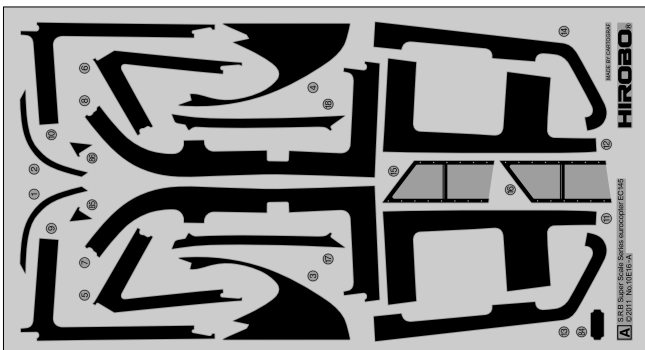

Decal C



REGA

Use Masking Sticker E supplied with this product. Apply each numbered sticker by referring to the figures below.

Point

Test out how the front body, rear body and front top cover fit together, then apply the masking stickers. Paint the front body, rear body and front top cover separately. You cannot paint these parts well if you leave them joined together.

Point

- Apply after letting the TS-26 Pure white paint dry for 3 to 6 hours.
- Apply masking stickers firmly so that no air gets underneath and the borders between paint look good.

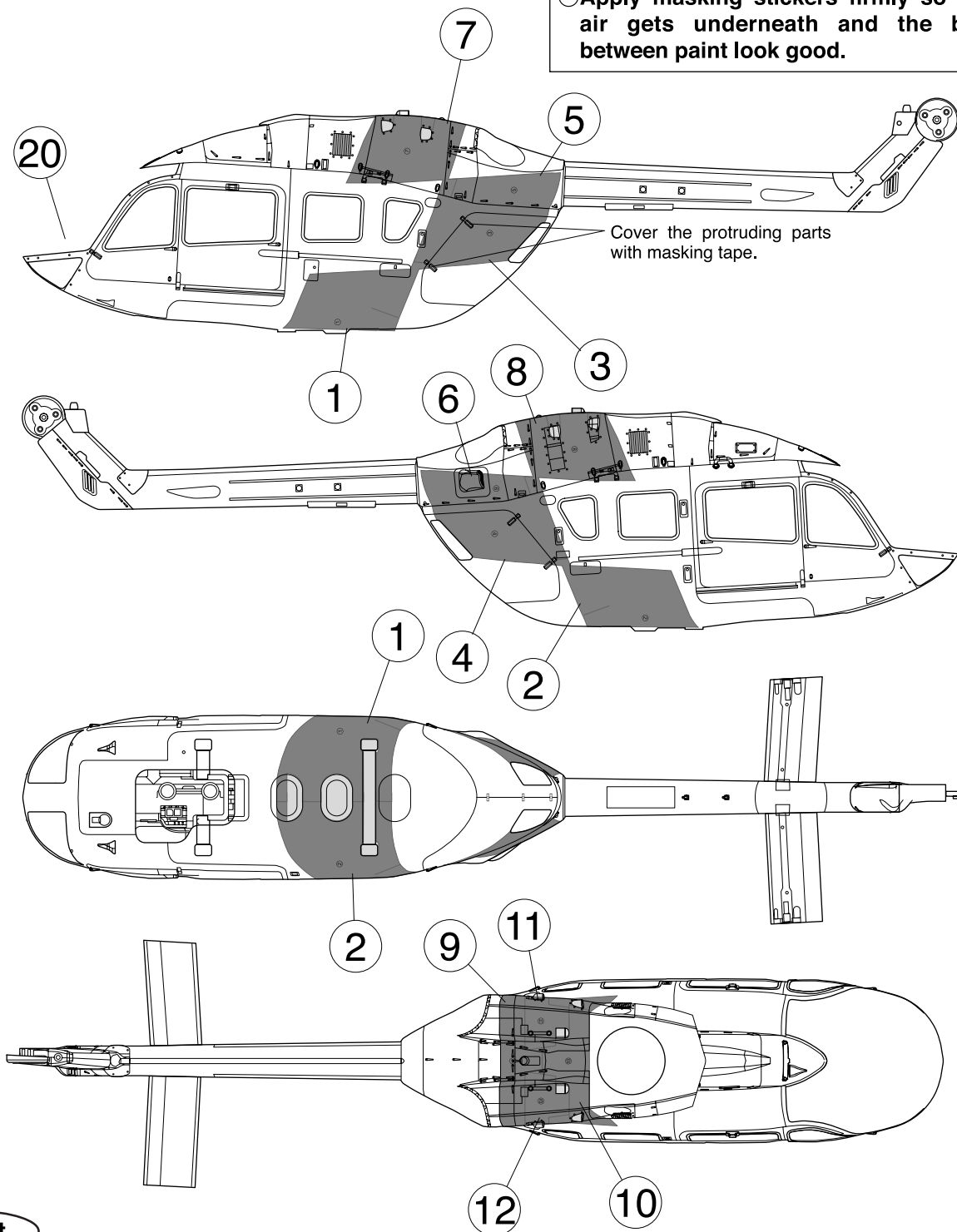

Point

Cover the windows from the inside so that no paint gets inside the body when painting. Cover the  areas with masking tape.

Vertical fin

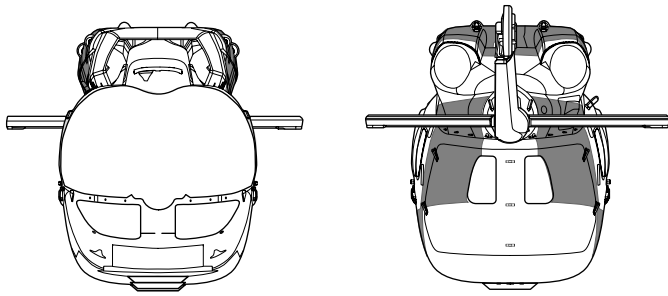
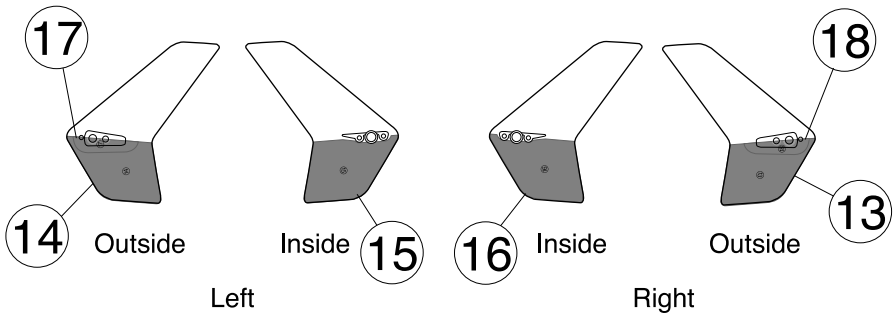

Front window

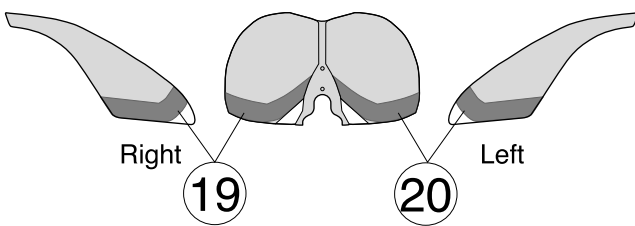



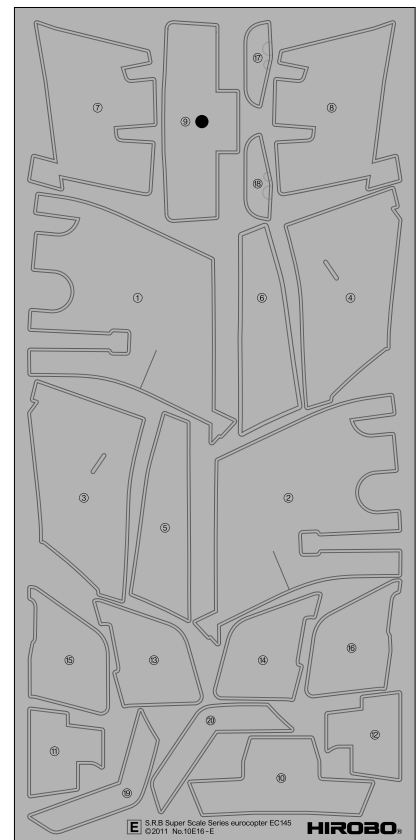



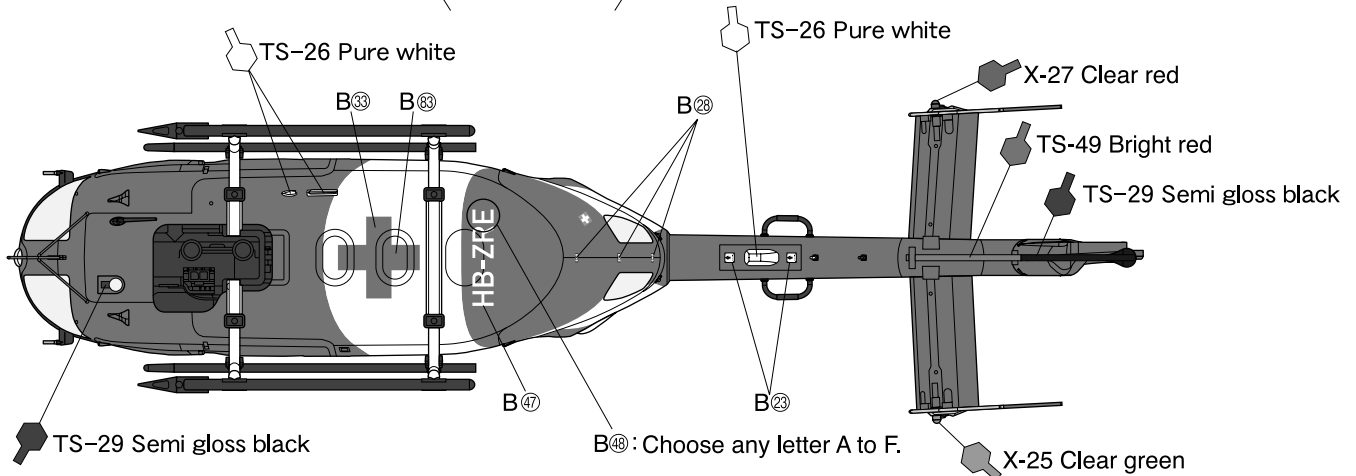
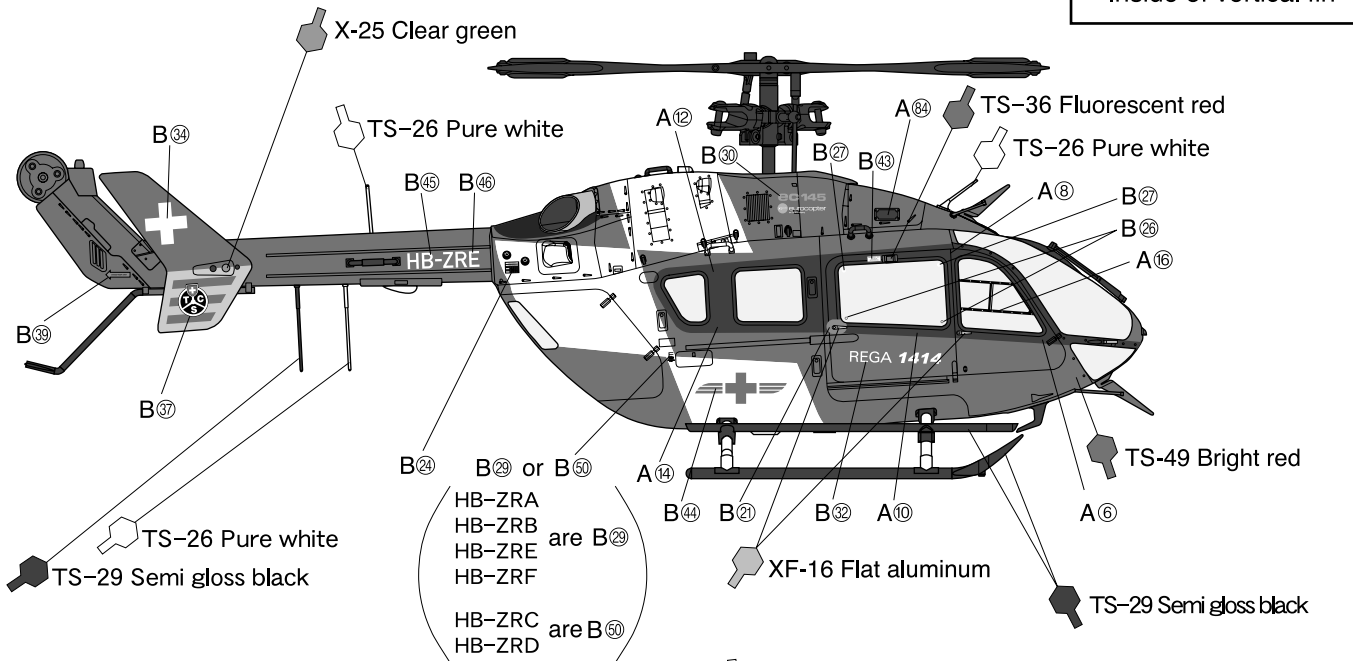
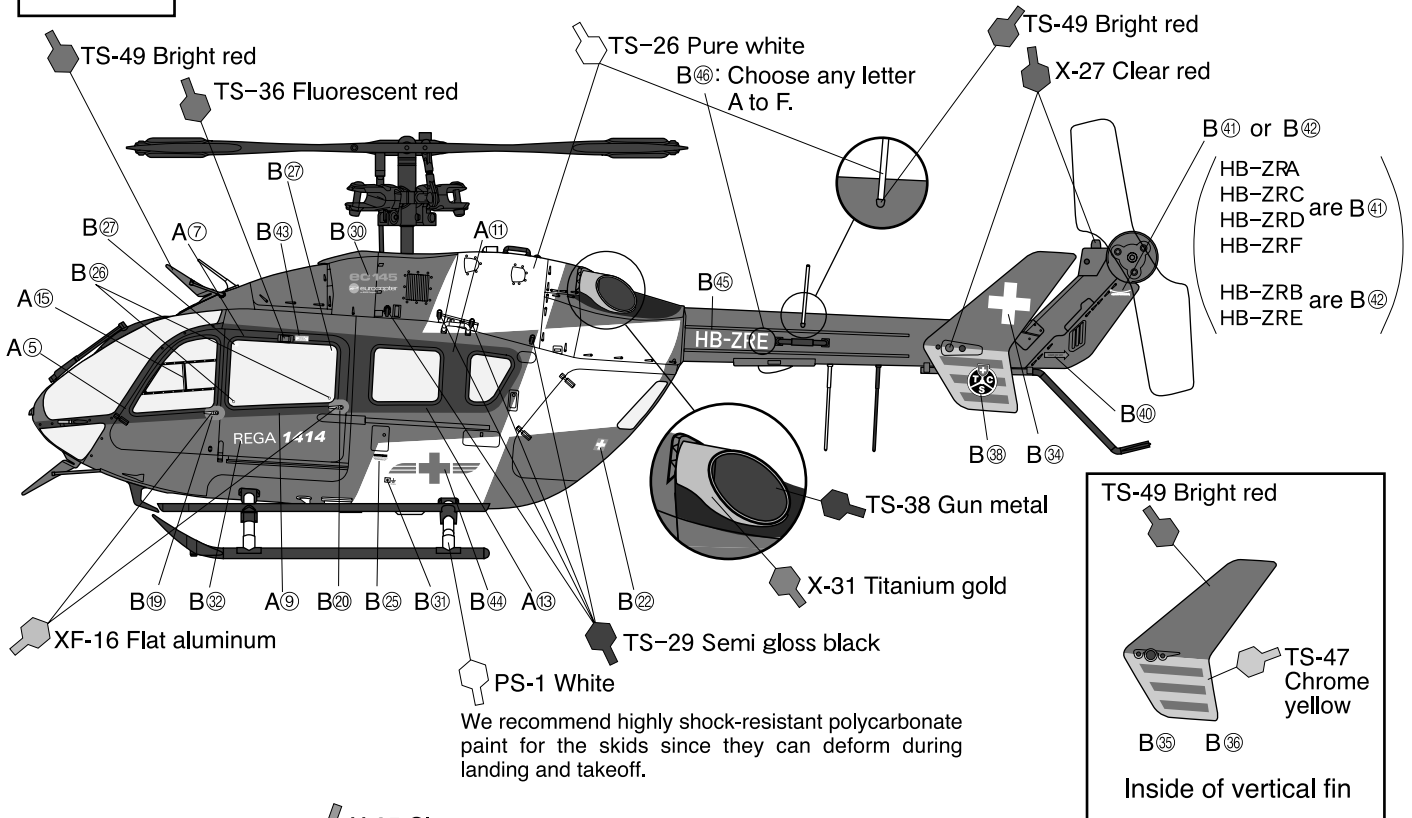

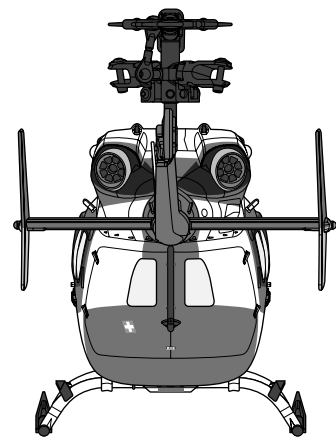



Masking seal E



REGA





-  TS-49 ● Bright red
-  TS-47 ● Chrome yellow
-  TS-29 ● Semi gloss black
-  TS-38 ● Gun metal
-  TS-26 ● Pure white
-  TS-36 ● Fluorescent red
-  TS-13 ● Clear * Use as finishing coat. (See page 13.)
-  X-31 ● Titanium gold
-  X-25 ● Clear green
-  X-27 ● Clear red
-  PS-1 ● White
-  XF-16 ● Flat aluminum

 This mark denotes numbers for Tamiya Paint colors.

Point

Tamiya Colors designated with the TS symbol are for Tamiya Color spray cans. X and XF represent Tamiya Acrylic Paint or Tamiya Enamel Paint. The PS symbol indicates polycarbonate paint.

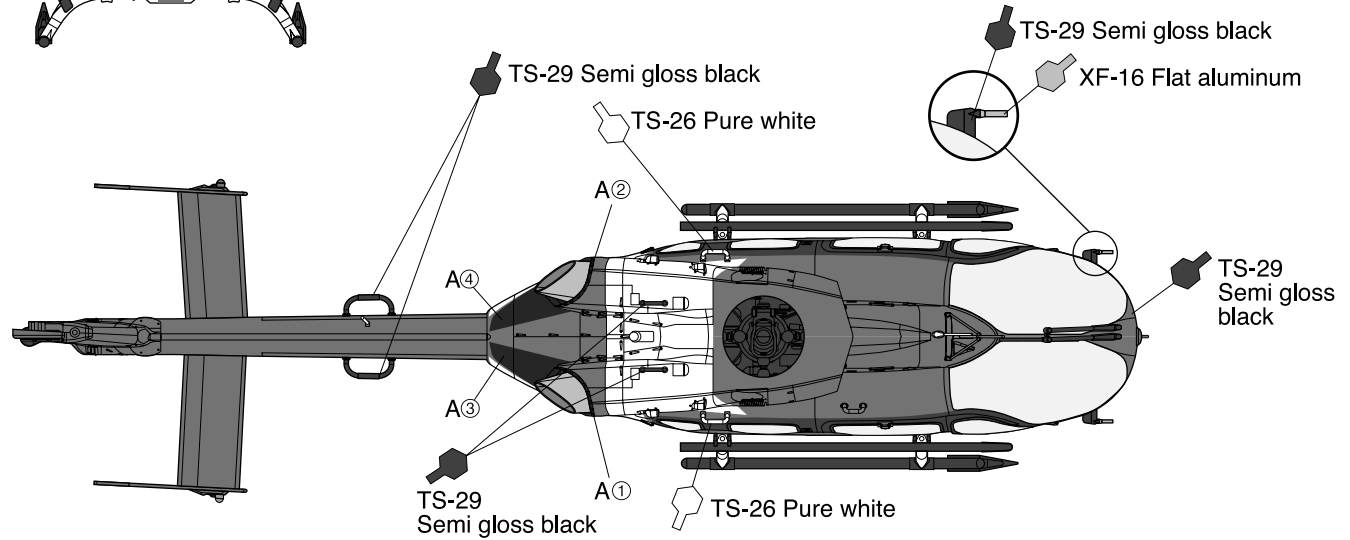

Decal A (Window frame decal is the same for all 3 models.)

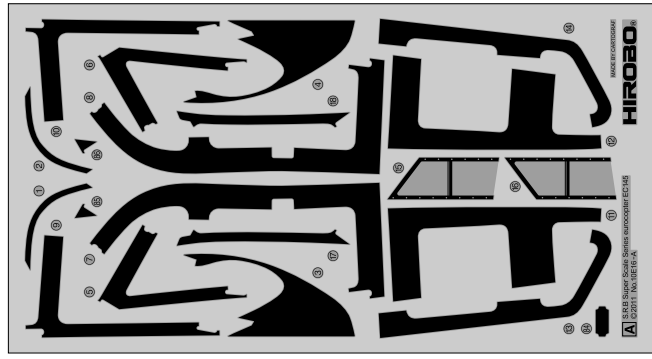

Decal B

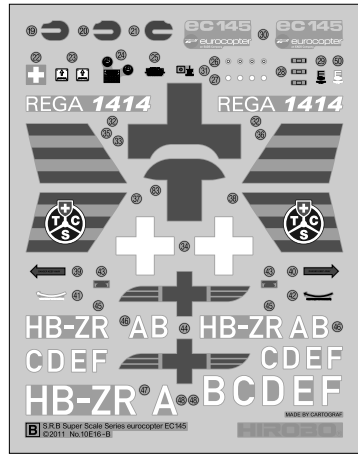

HESSEN POLIZEI

Use Masking Sticker G supplied with this product. Apply each numbered sticker by referring to the figures below.

Point

Test out how the front body, rear body and front top cover fit together, then apply the masking stickers. Paint the front body, rear body and front top cover separately. You cannot paint these parts well if you leave them joined together.

Point

- Apply after letting the AS-20 Insignia white and TS-65 Pearl clear paints dry for 3 to 6 hours.
- Apply masking stickers firmly so that no air gets underneath and the borders between paint look good.

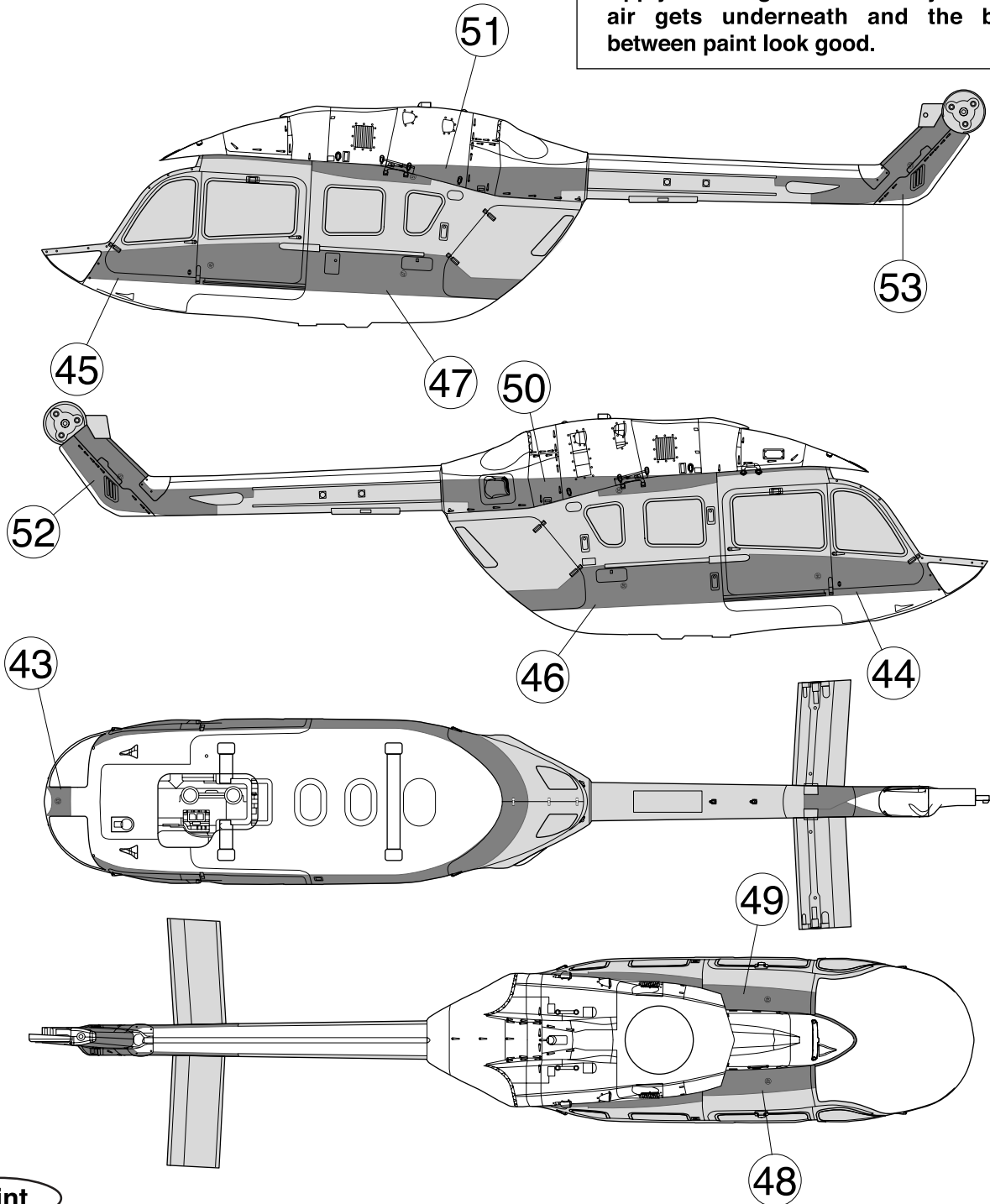

Point

Cover the windows from the inside so that no paint gets inside the body when painting. Cover the  areas with masking tape.

Vertical fin

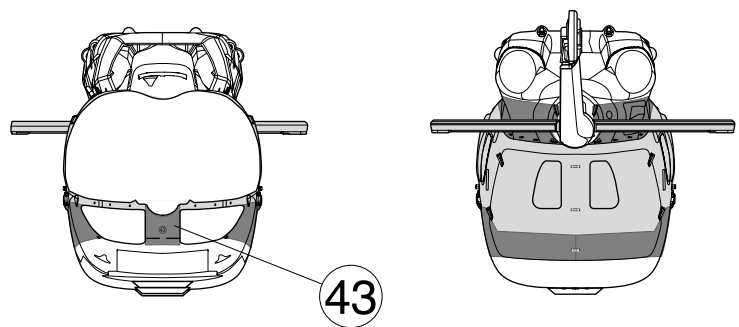
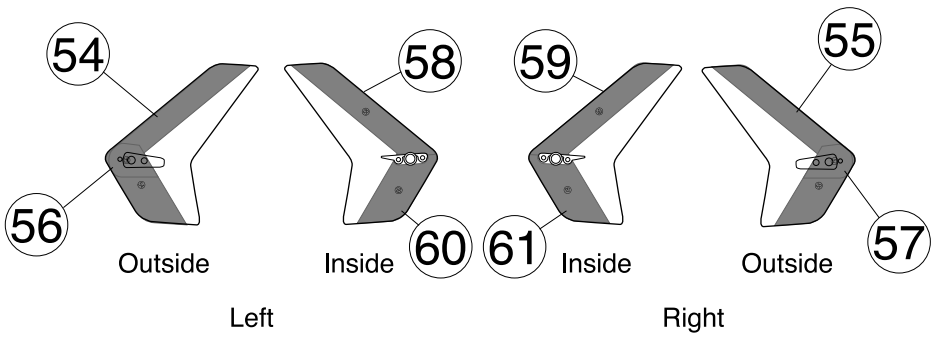

Front window

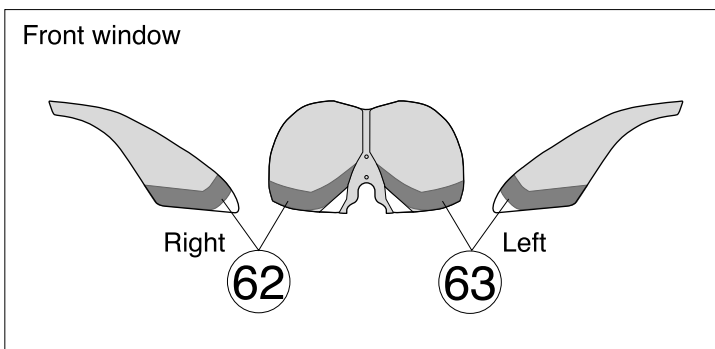

Masking seal G

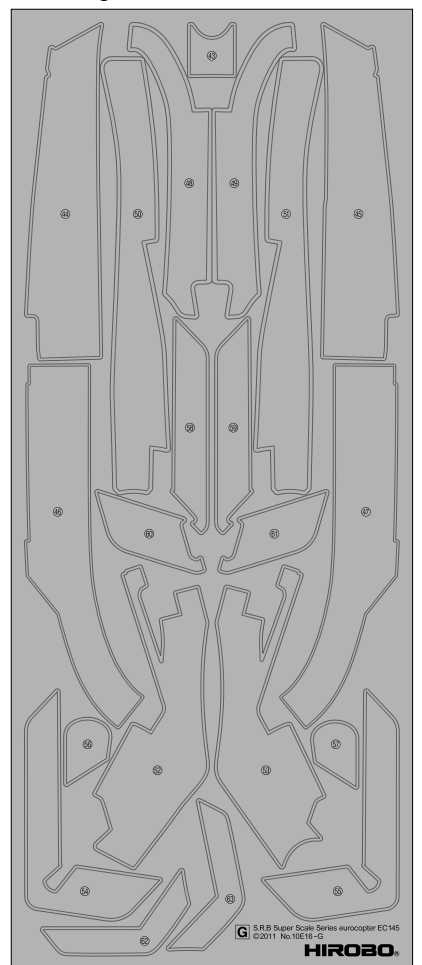

HESSEN POLIZEI

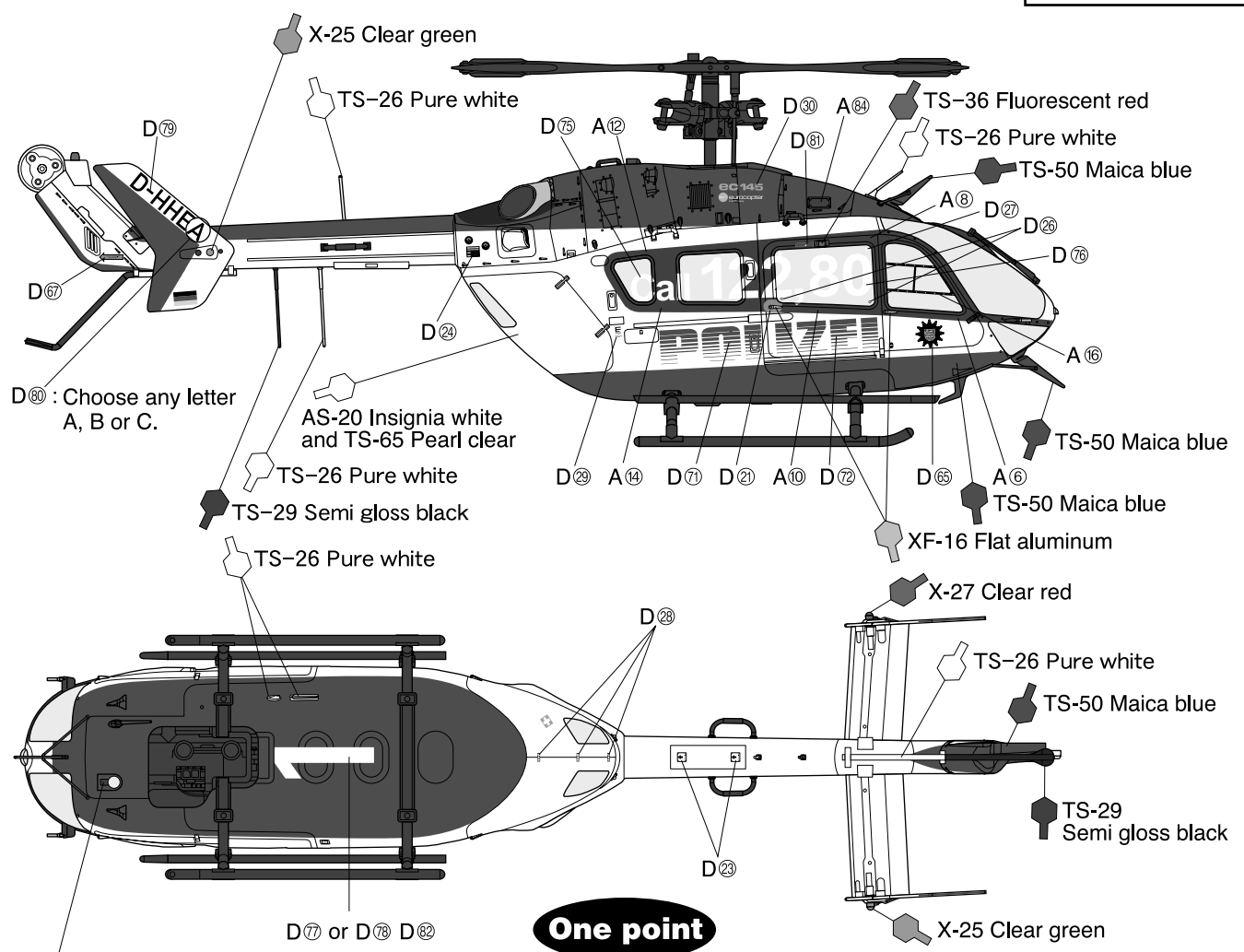
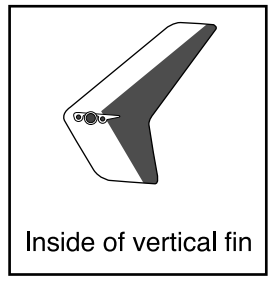
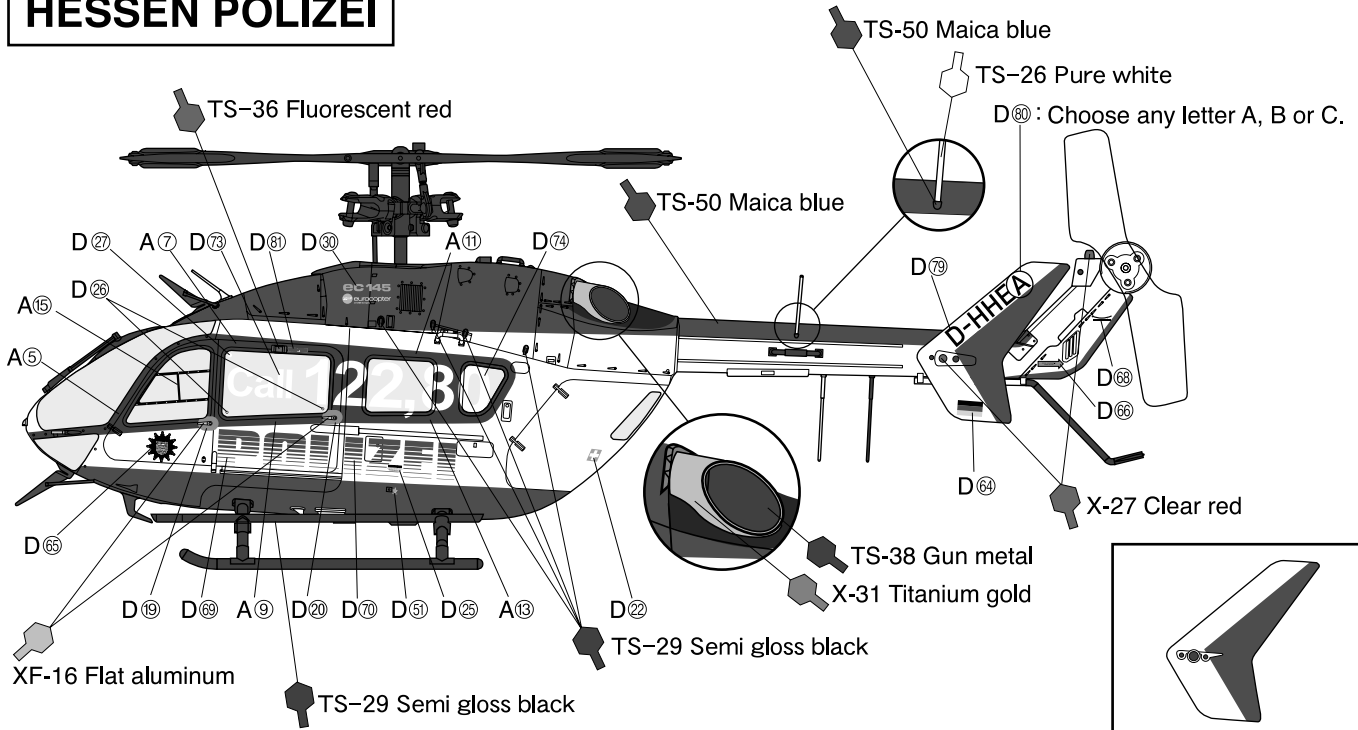

D⁷⁷ or D⁷⁸ D⁸²

- D-HHEA → 1
- D-HHEB → 2
- D-HHEC → 3

TS-29 Semi gloss black

One point

The "Call 122,80" lettering on parts D-⁷³, ⁷⁴, ⁷⁵ and ⁷⁶ was displayed by the Land Hessen Police until 2010. Since 2011 it is no longer used. Apply it to your model if you'd like.

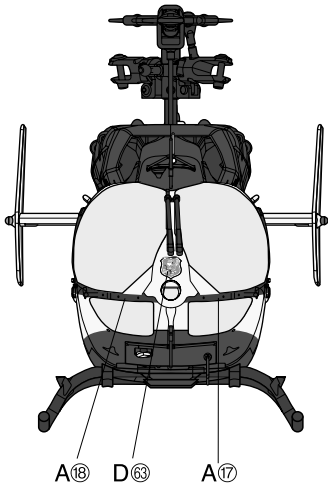

- TS-50 ● Maica blue
- AS-20 ● Insignia white+
- TS-65 ● Pearl clear * Paint TS-65 after AS-20.
- TS-29 ● Semi gloss black
- TS-38 ● Gun metal
- TS-26 ● Pure white
- TS-36 ● Fluorescent red
- TS-13 ● Clear * Use as finishing coat. (See page 13.)
- X-31 ● Titanium gold
- X-25 ● Clear green
- X-27 ● Clear red
- XF-16 ● Flat aluminum

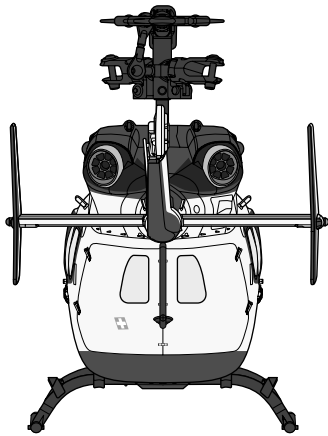

This mark denotes numbers for Tamiya Paint colors.

Point

Tamiya Colors designated with the TS and AS symbols are for Tamiya Color spray cans. X and XF represent Tamiya Acrylic Paint or Tamiya Enamel Paint.

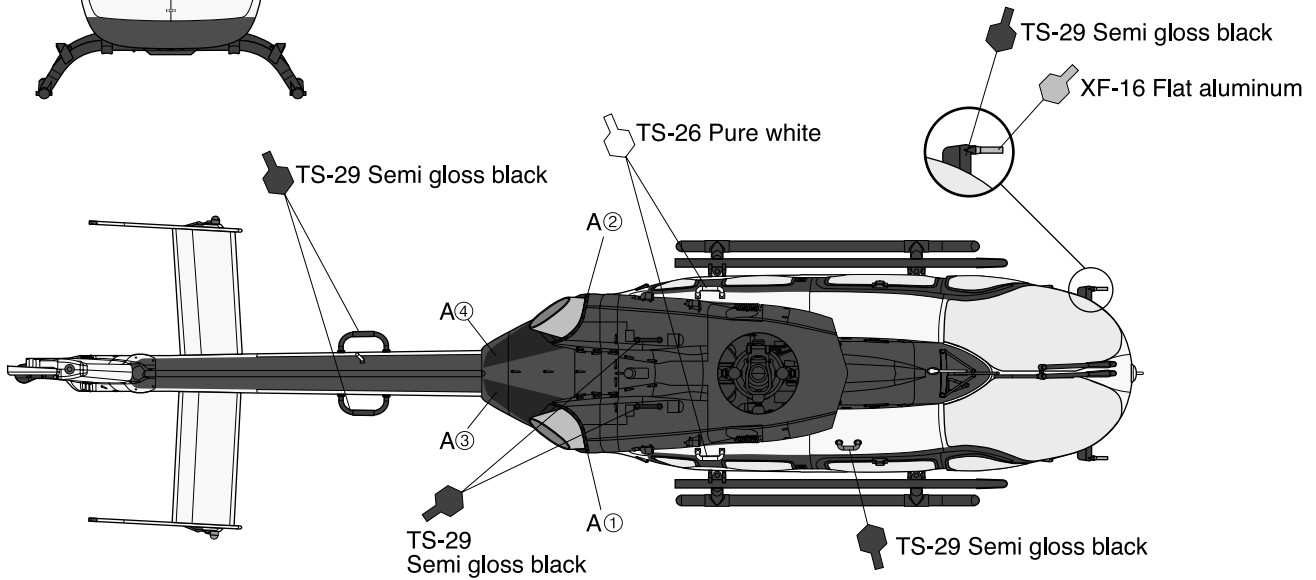

Decal A (Window frame decal is the same for all 3 models.)

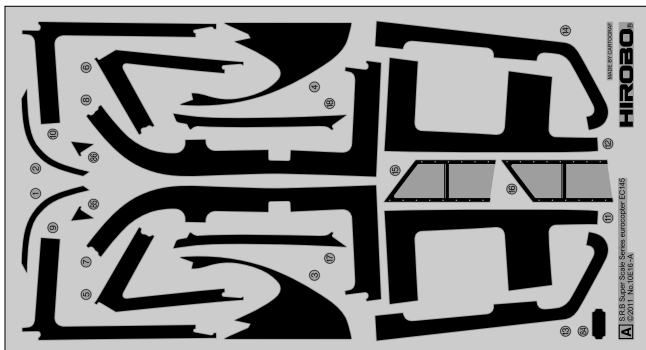





Decal D



08 / Unit Assembly

Please be advised to start recharging the battery before assembly. (Refer to page 8.)

1. Center hub and seesaw assembly

-  M1.4X5TS 3
-  M1.4X8 shoulder 1
-  M2X10TS 2
-  EX ø4 ball 3

Point

Pay attention to the direction of the EX ø4 ball when installing.

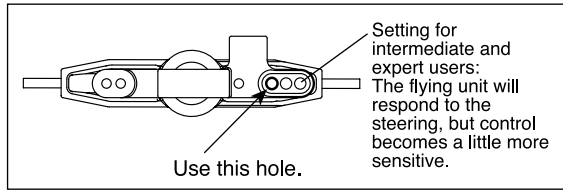
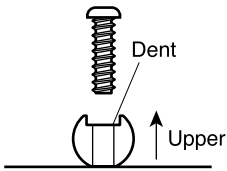

Completely tighten the screw, then loosen it by about 1/4 or 1/2 a turn so that the seesaw moves slightly.

M1.4X8 shulder

Pay attention to the direction of the screw when inserting.

M2X10TS
Temporarily set

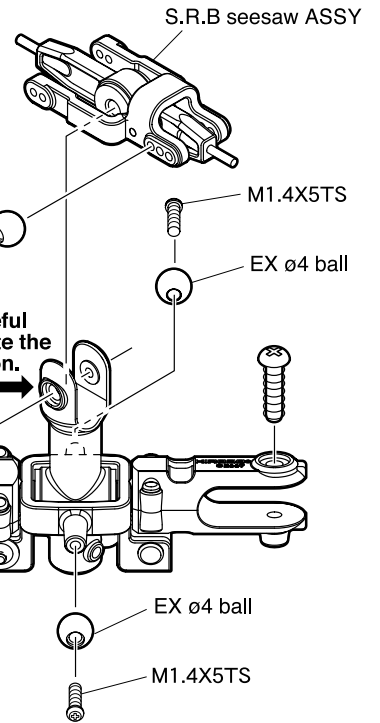

Be careful and note the direction.

S.R.B center hub
Blade holder ASSY
(Cannot disassemble)

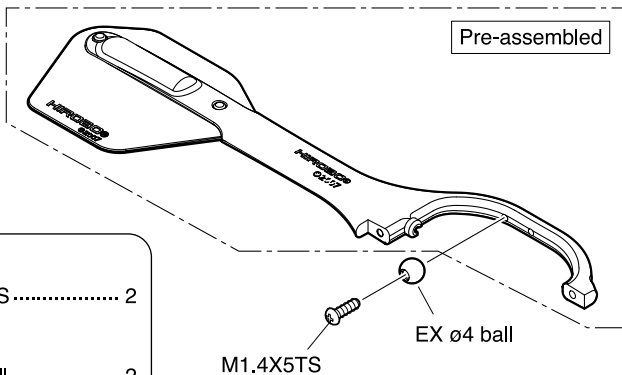

2. Stabilizer assembly



-  M1.4X5TS 2
-  EX ø4 ball 2

Point

Pay attention to the direction of the EX ø4 ball when installing.

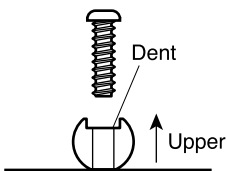

Regarding the position of the ø4 balls in the stabilizer

Setting for beginners:
The flying unit will be stable, and steering will be easy.
The balls are attached in these positions when the unit is shipped from the factory.

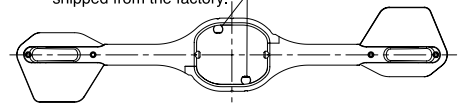

Setting for intermediate and expert users:
The flying unit will respond to the steering, but control becomes a little more sensitive.

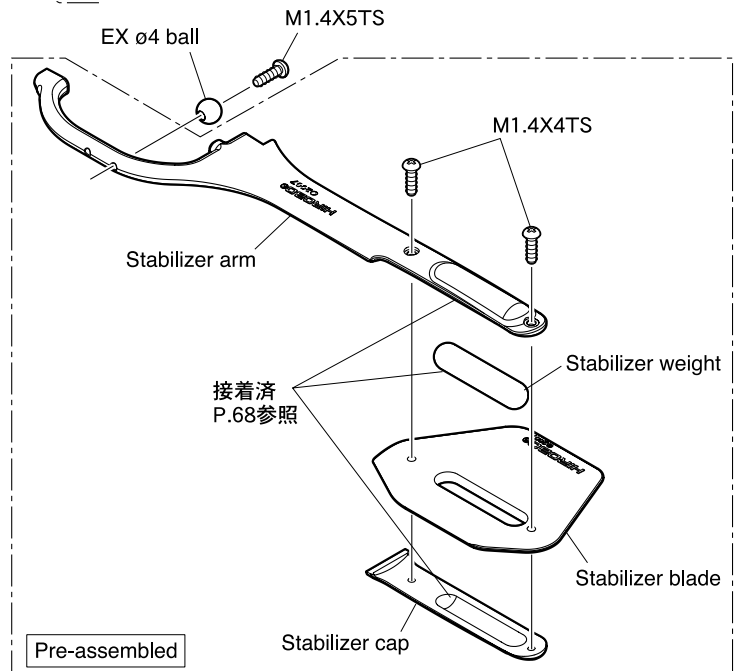
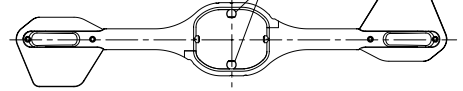

3. Rotor head assy assembly

- ⊕  M1.4X4TS 2
- ⊕  M1.4X3TS 4

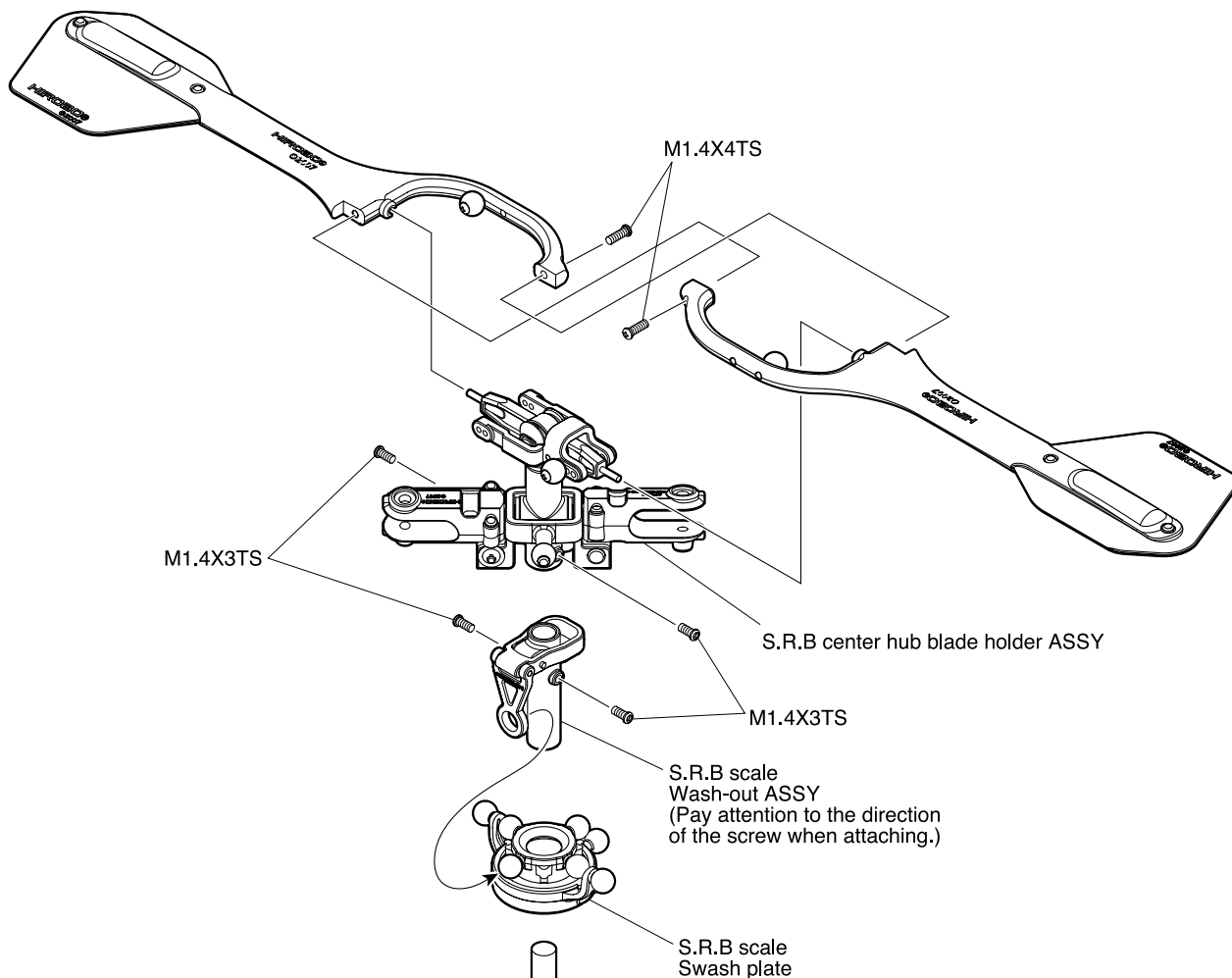

Point

【Note about the rod end】

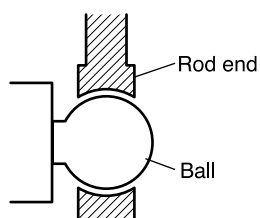

The rod end functions as a joint. When you attach it, be sure it clicks and correctly fits to the ball. If it is out of position or pressed too far inside, the rod end cannot function correctly resulting in a crash.

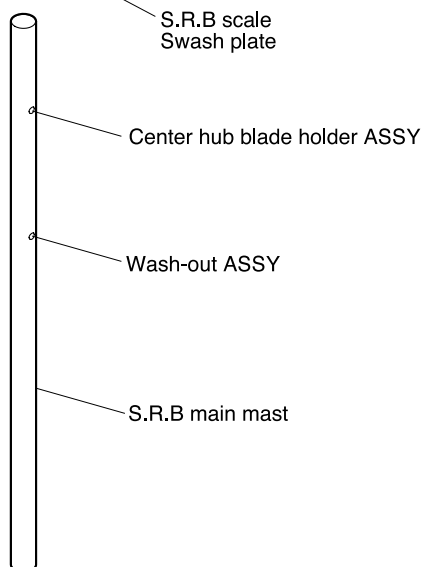

Sectional drawing

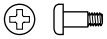

4. Main frame assembly

	M1.4X5TS..... 5
	M1.7X5.1 shulder..... 1
	EX ø4 ball..... 1
	Brg. ø4Xø7X2.5ZZ..... 2

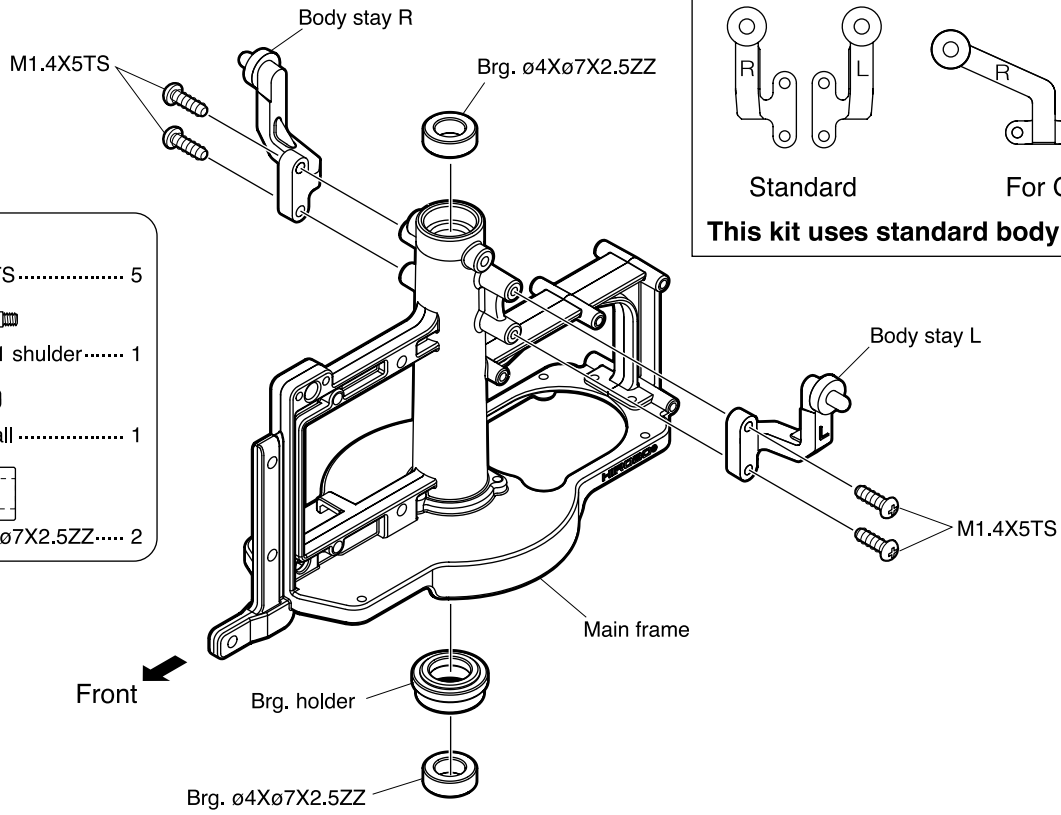

Point

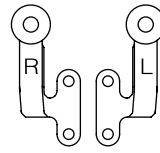

Standard

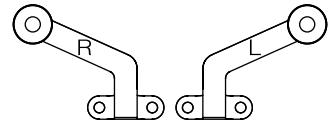

For Quark SG

This kit uses standard body stays.

Point

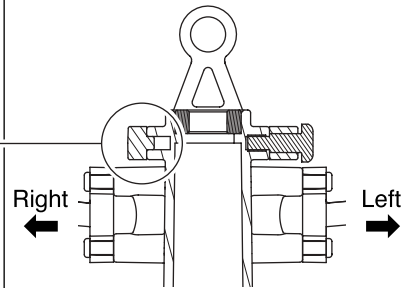

Insert the protrusions straight into the main frame's holes.

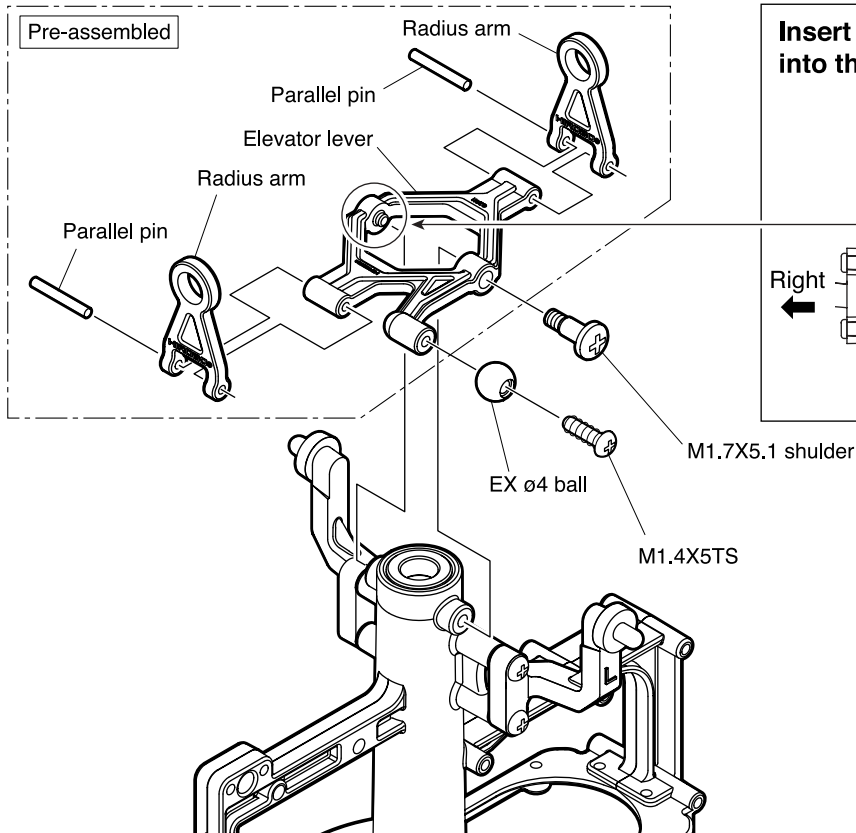

Cross-section



5. Main motor assembly

-  M1.4X3TS..... 5
-  M2X3SS..... 1
-  M2X4 truss 2

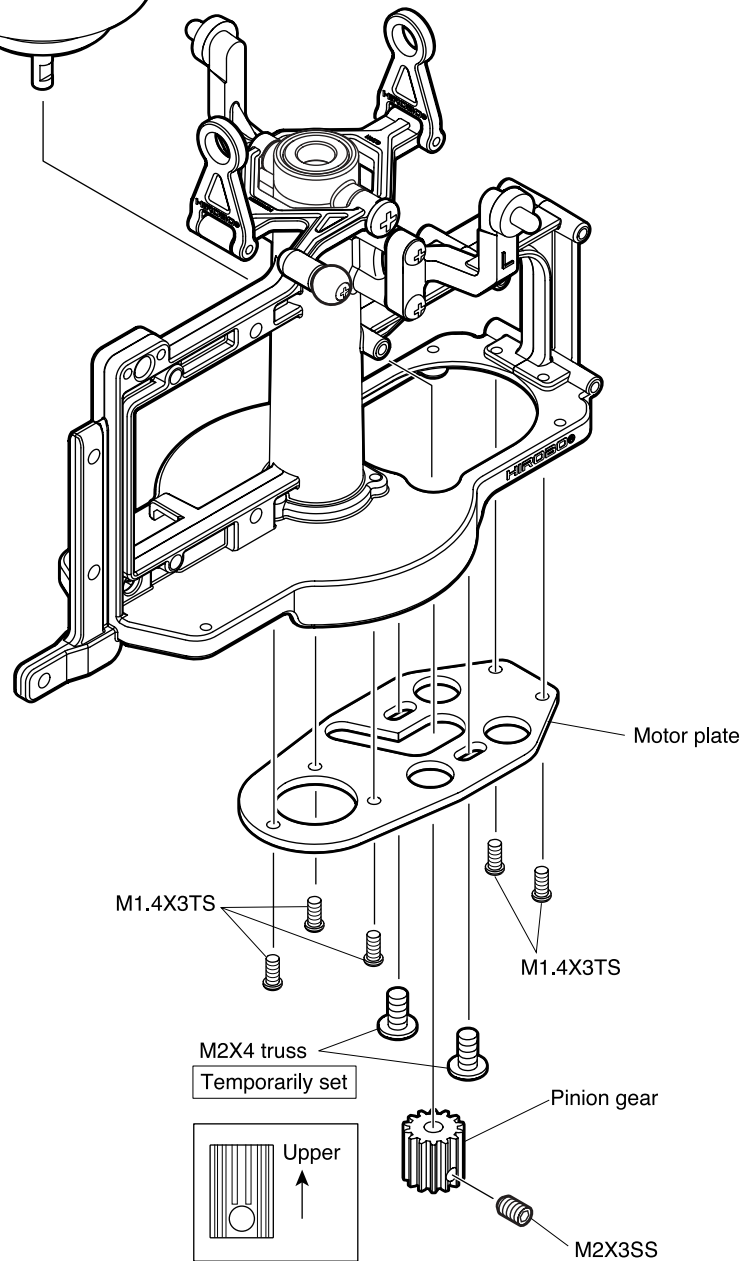
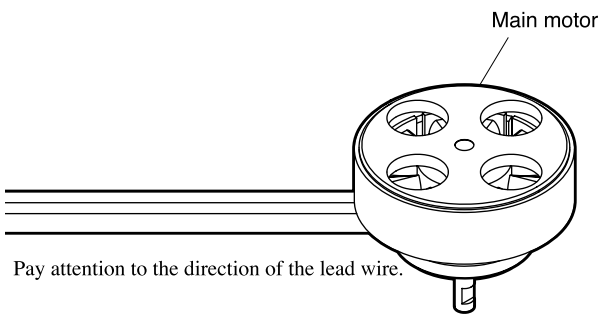
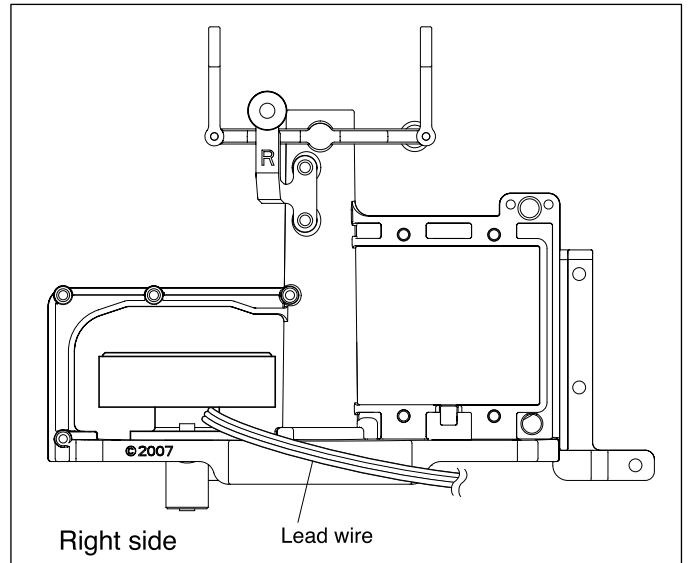

Point

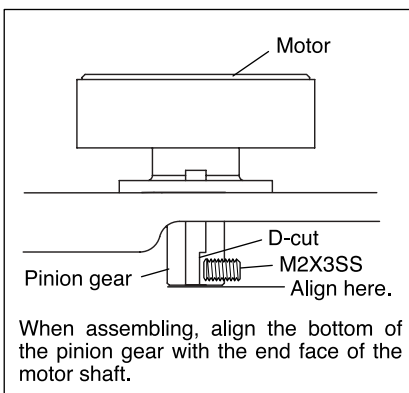

6. Rotor head assy installation



 M2X6CS 1

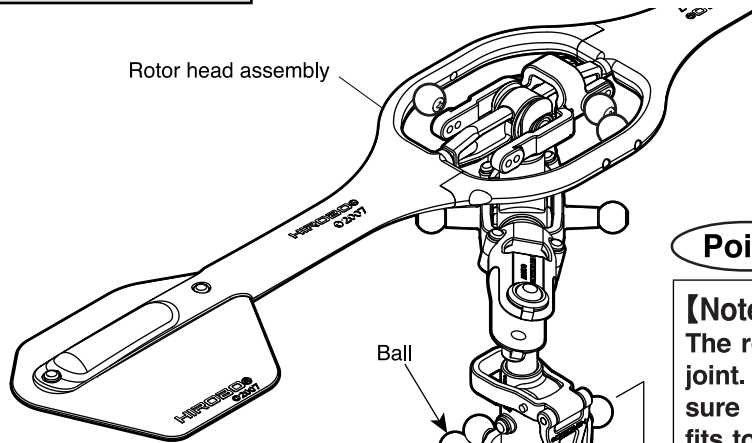

Point

[Note about the rod end]
 The rod end functions as a joint. When you attach it, be sure it clicks and correctly fits to the ball. If it is out of position or pressed too far inside, the rod end cannot function correctly resulting in a crash.

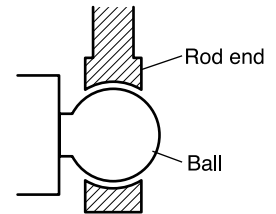

Sectional drawing

Point

In order to stop the rotor head from wobbling up and down, when tightening the M2X6CS bolt, press the wash-out assy against the upper bearing and the main gear against the lower bearing.

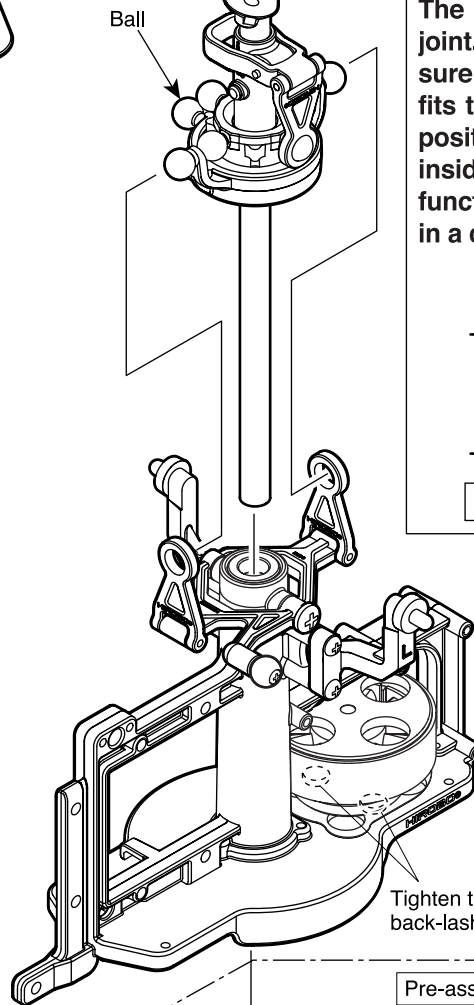
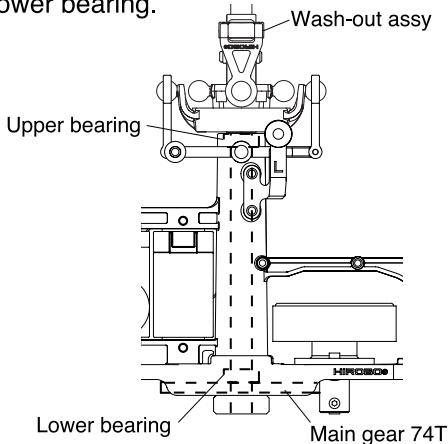

Tighten the M2X4 trusses after back-lash adjustment.

Point

○ Adjusting the backlash

Adjust the position of the main motor in order to create enough space for the main gear to rotate easily. If a sheet of plastic (from plastic bags used for product packaging) can fit between the main gear and the pinion gear, the backlash is adjusted ideally.

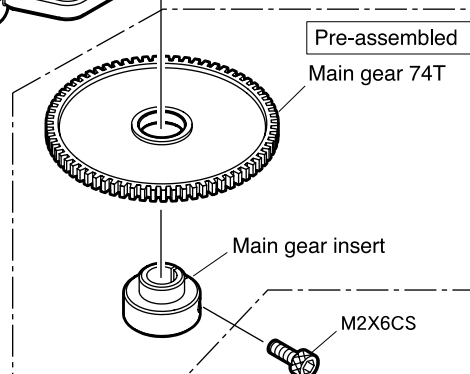
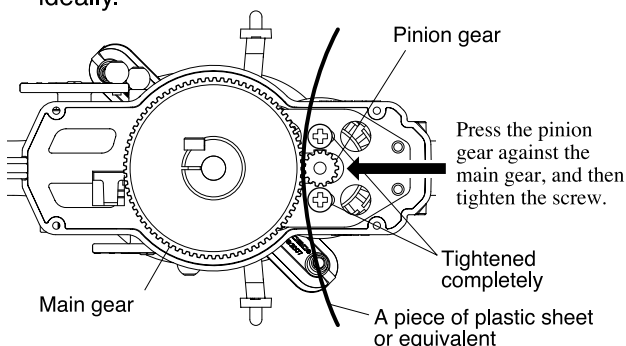

7. Control unit and servos installation

- ⊕ M1.7X8TS 3
- ⊕ M2X5TS 4

Point

Attach straight onto the rear section of the main frame. Make sure there is no interference with the servo horns or linkage.

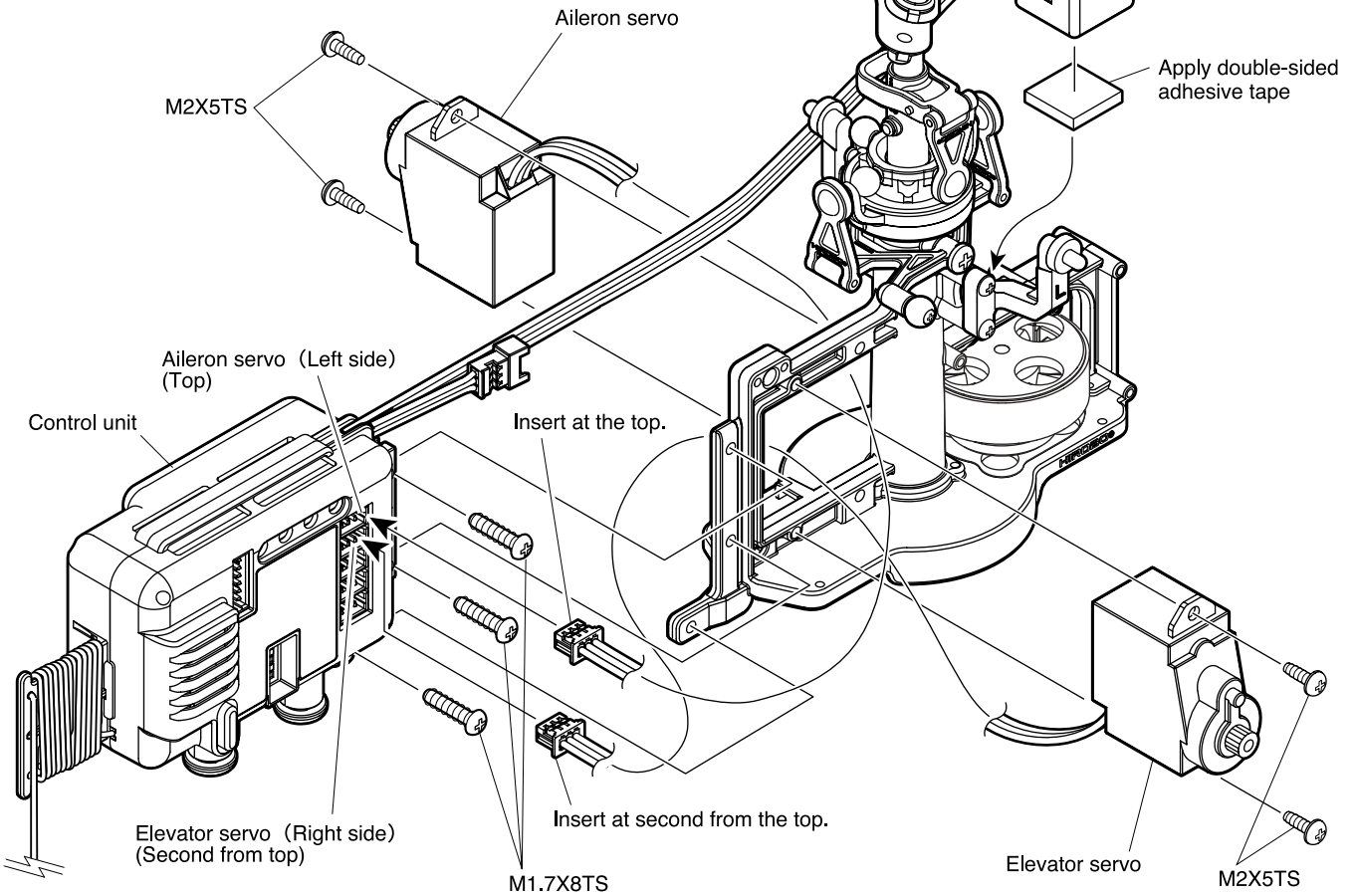
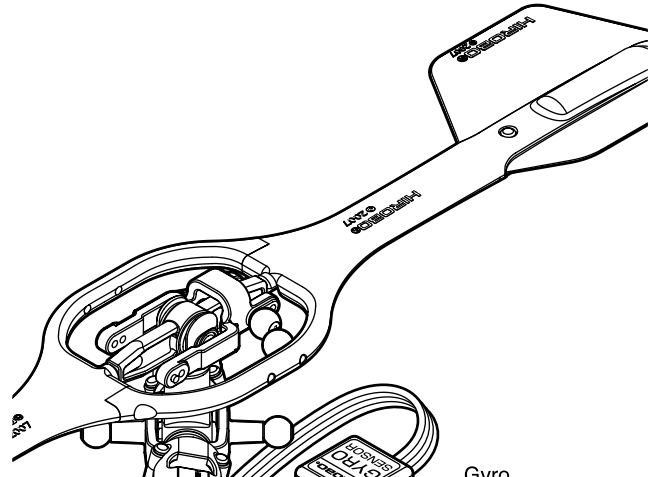
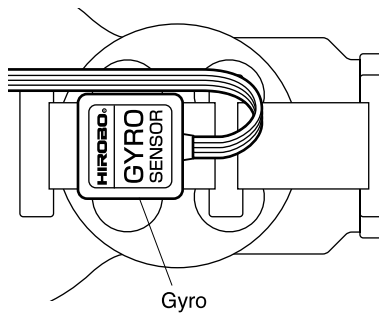

Connection Diagram

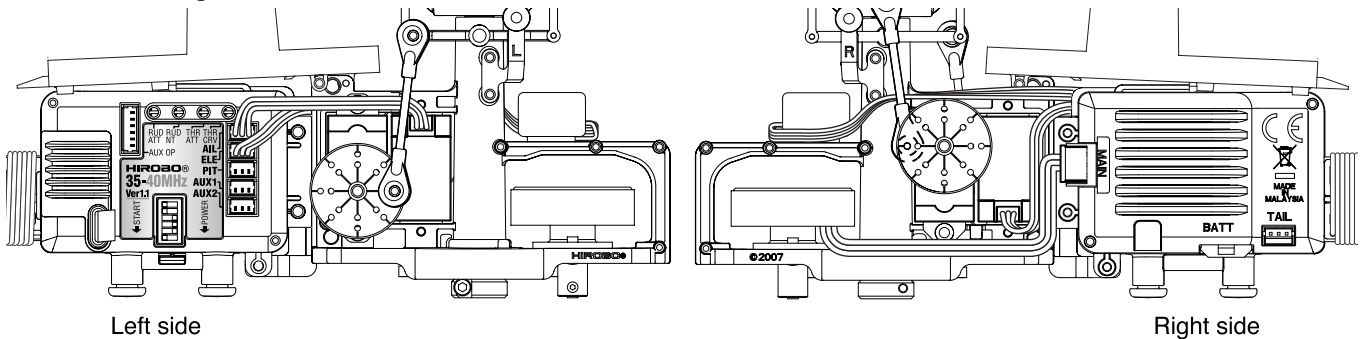

Left side

Right side

8. Servo horn assembly

⚠ Caution

Cannot adjust properly if the servos and servo horns are out of place from each other. Due to improper adjustments, at worst, the servo or the control unit may be damaged.

① Connection of the servo

Connect each servo, battery and back LED to the control unit as shown in the figure, then turn on the power switch while pressing the start switch.

The back LED will then start flashing in red.

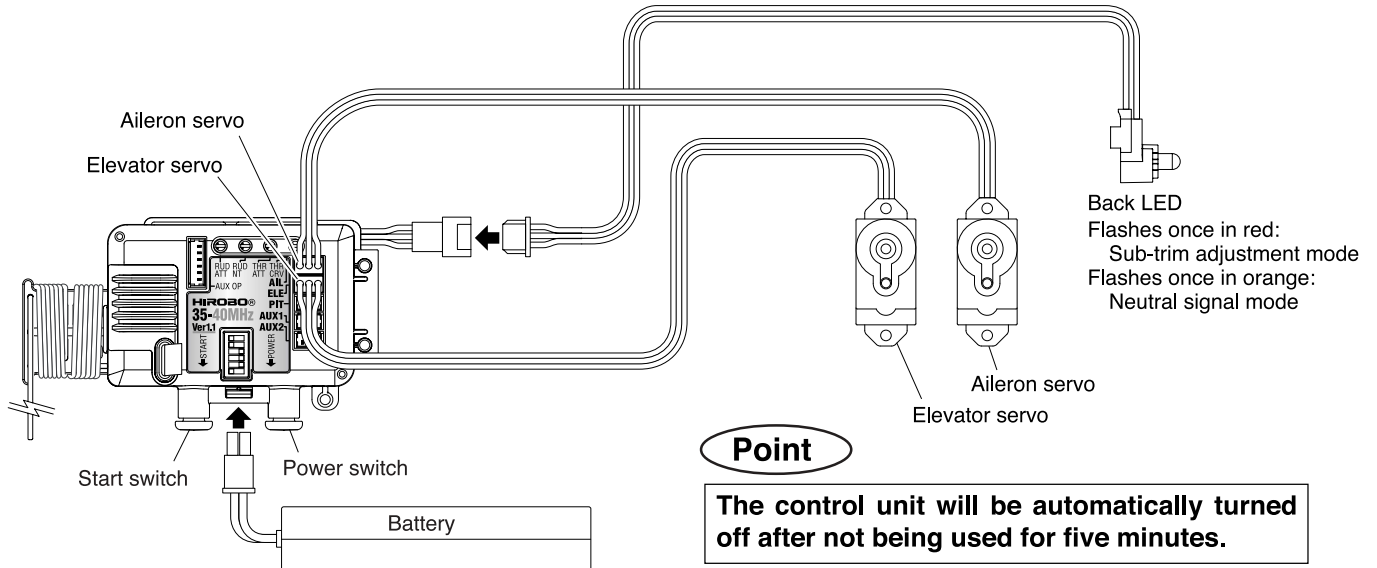
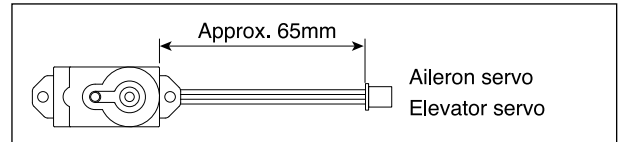

② Installation of the servo horn

If you press the start switch once, the LED starts flashing in orange and the control unit outputs the neutral position signal to the servo.

Position each servo and their horns as shown in the figure.

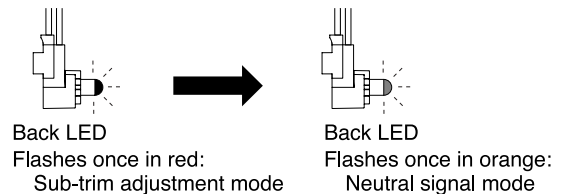

Point

⊕ ()	M1.7X4TS-2	2
⊕ ()	M1.4X5TS	2
⊙ ⊖	EX ø4 ball	2

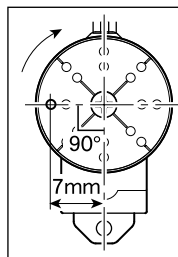

Slowly rotate the servo horn as you fit it into the servo's grooves and find the holes to put it into position as shown in the figure.

Point

Here you adjust the attachment position of the servo horns without using the control unit's sub-trim adjustment feature. The control unit's sub-trim is set to zero when shipped. See page 78 for how to use the sub-trim's adjustment feature.

③ Attach an EX ø4 ball to the servo horns connected in Step ② as shown in the figure.

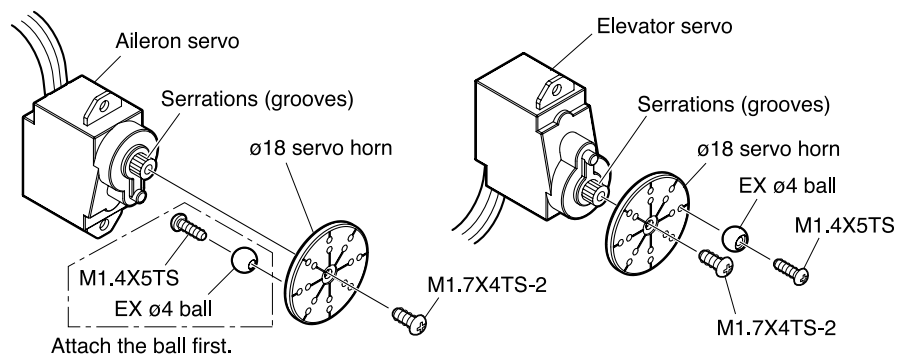

④ Hold down the power switch. The back LED and power will turn off.

⑤ Remove the battery.

9. Linkage rod assembly



ø4 rod end 9

Adjust rod M1.4X45 1

Adjust rod M1.4X40 1

Adjust rod M1.4X21 1

Adjust rod M1.4X18 1

Adjust rod M1.4X7 1

Point

【Note about the rod end】

The rod end functions as a joint. When you attach it, be sure it clicks and correctly fits to the ball. If it is out of position or pressed too far inside, the rod end cannot function correctly resulting in a crash.

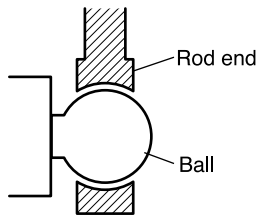

Sectional drawing

Assemble each adjust rod and the ø4 rod end as shown below.

Full scale

Elevator rod (1 set)

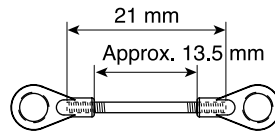

Stabilizer control rod (1 set)

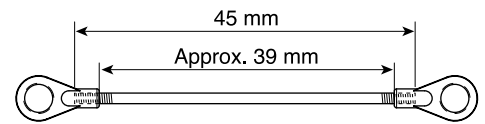

Pitch rod (1 set)

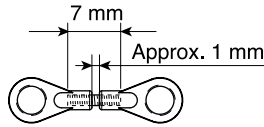

Aileron rod (1 set)

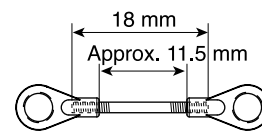

Mixing arm rod (1 set)

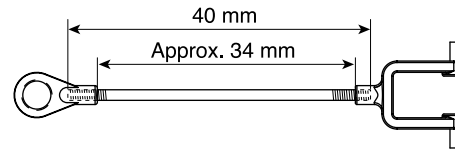

Stabilizer control rod

Pitch rod

Mixing arm rod

Use this hole to attach the mixing arm rod.

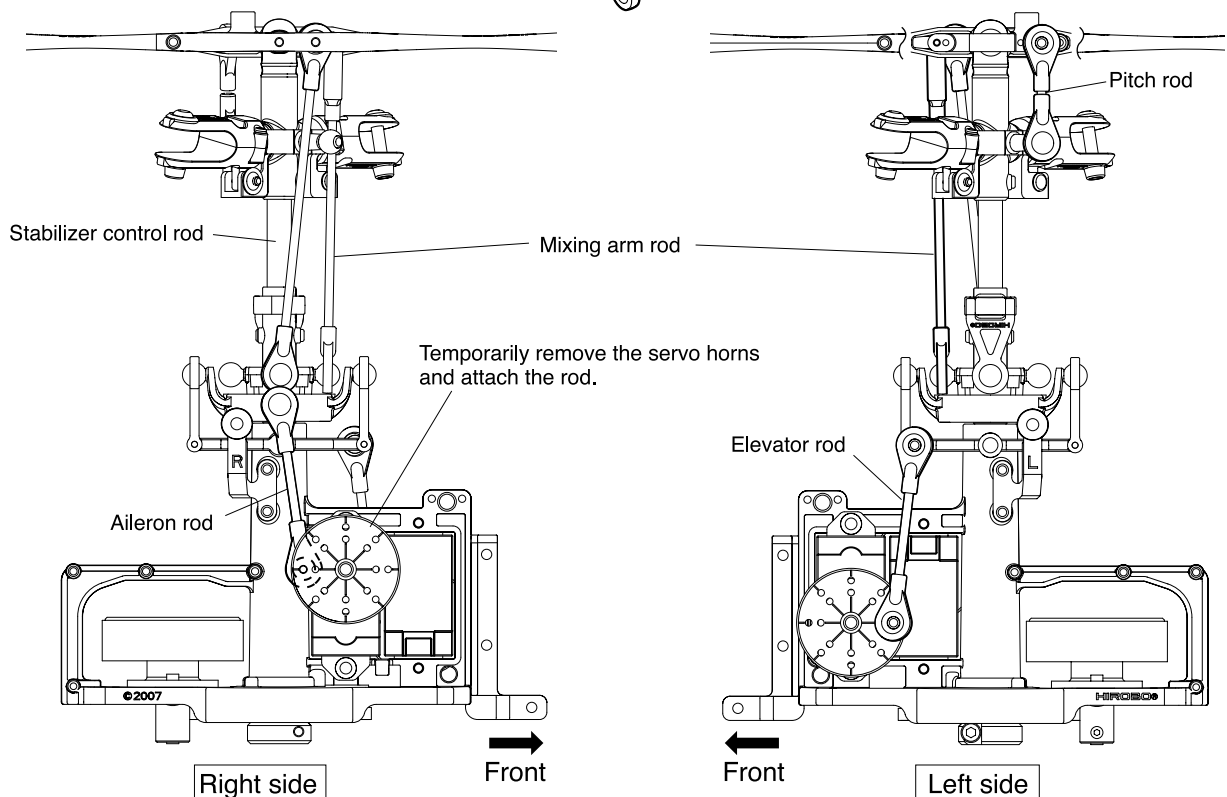

10. Battery holder installation

For those who purchased a full set (or a set without the programmable transmitter) with the pre-painted body, assemble the body by following the procedures specified here.

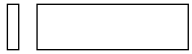
-  M1.4X5TS..... 6
-  Double sided adhesive tape 6X20 ... 2

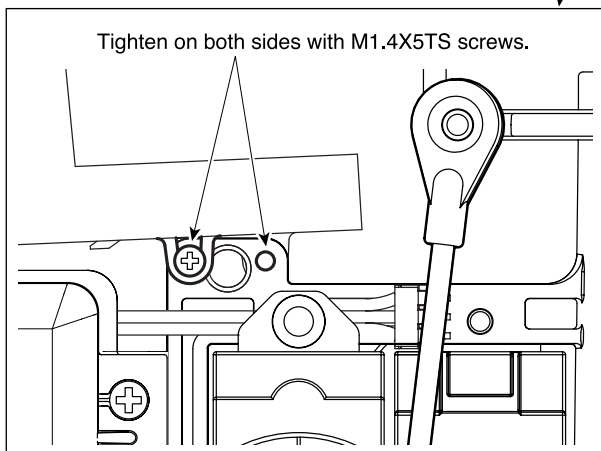
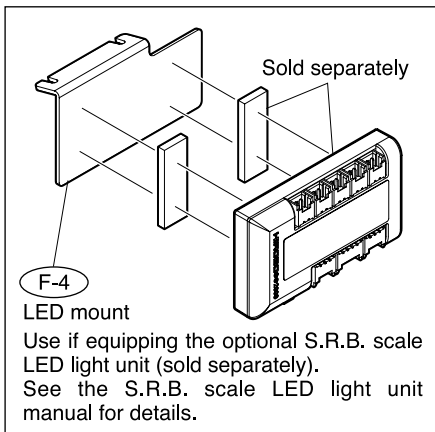
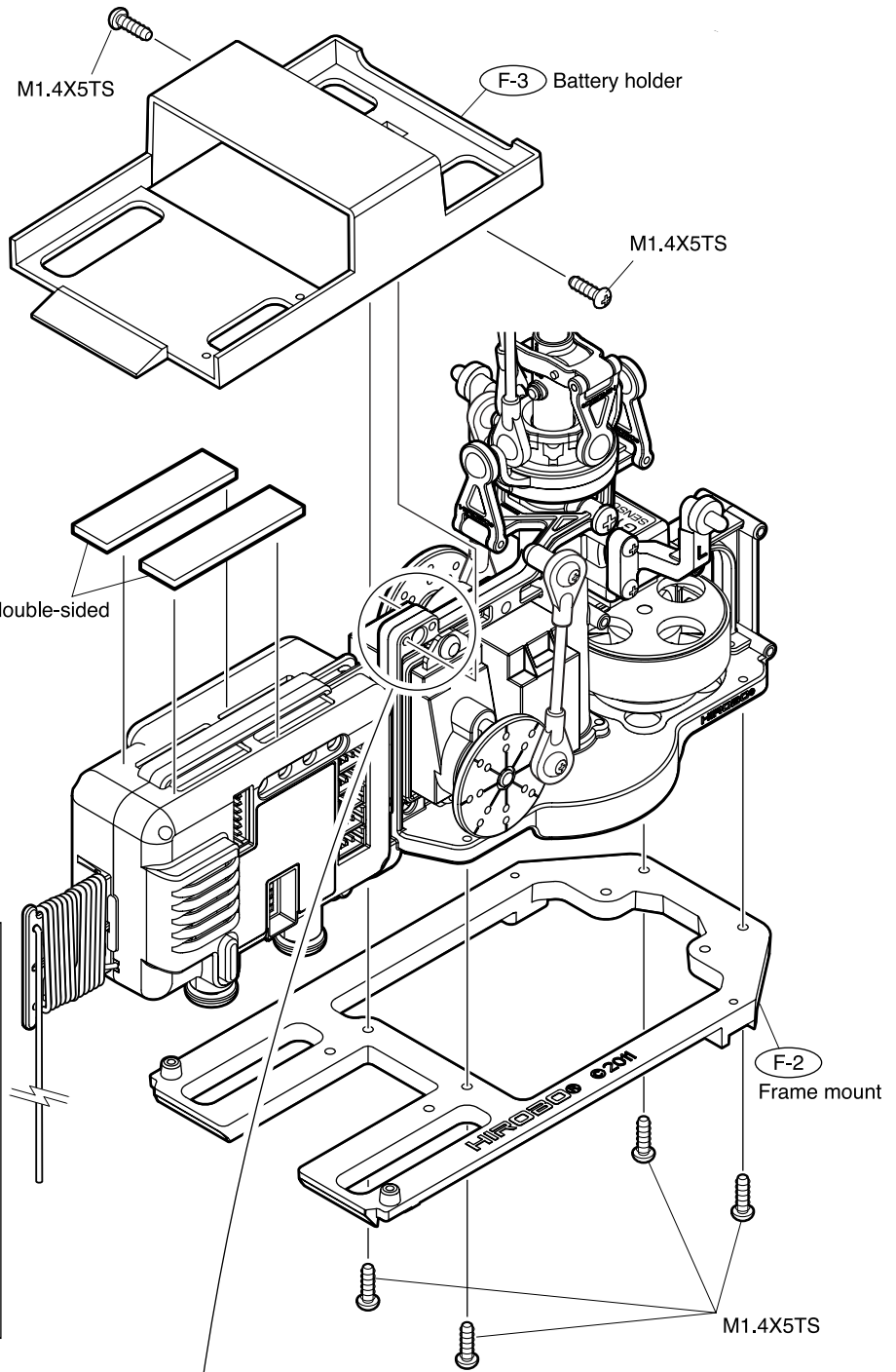

Point

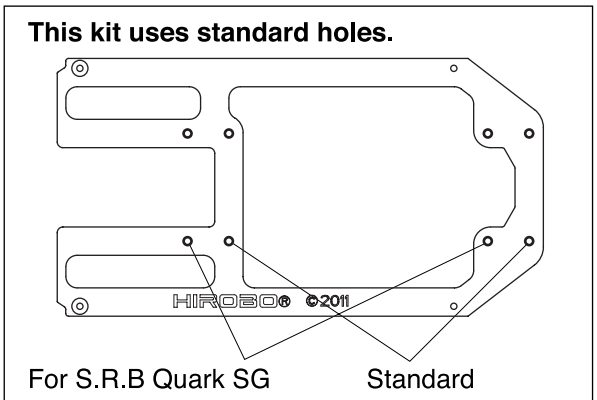

11. Tail motor installation

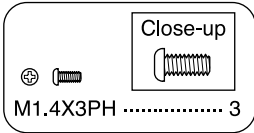

⚠ Caution

Verify screw length and type to prevent motor damage.

⊘ Do not use tapping screws.

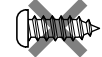

⊘ Do not use long screws.

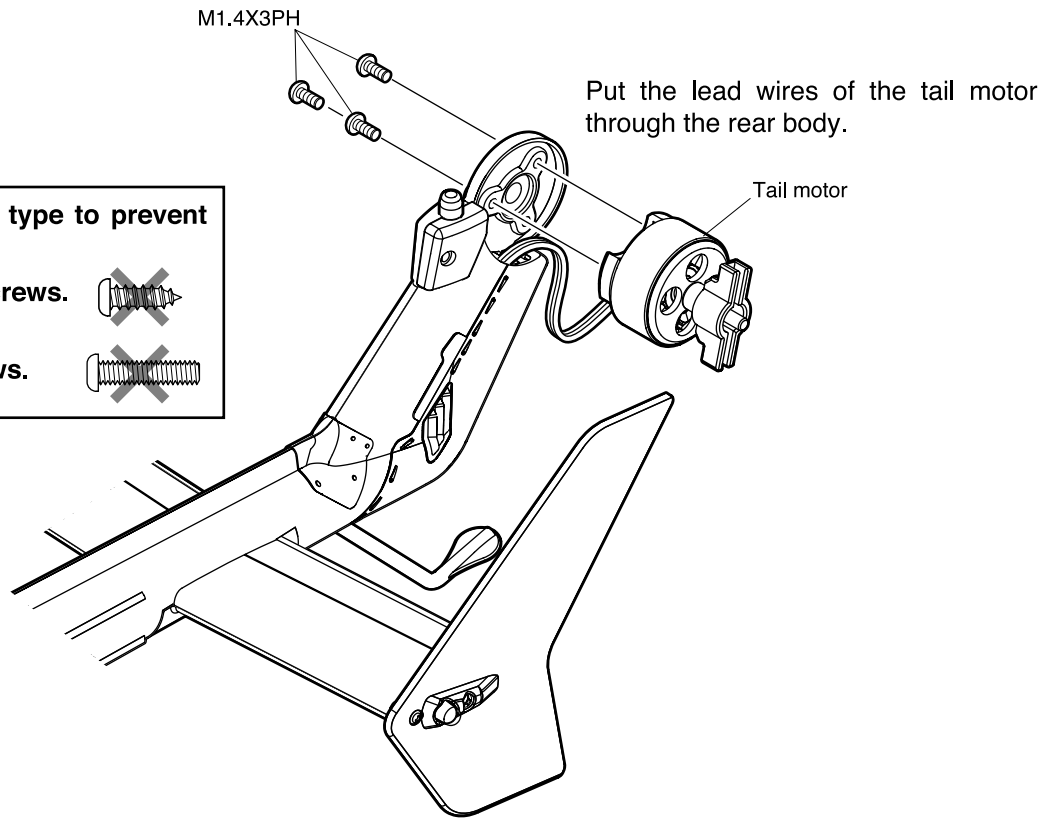
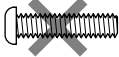

12. Back LED installation

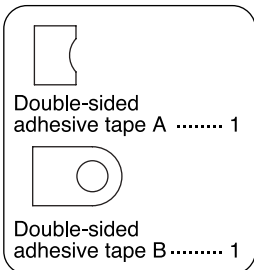

Apply the supplied double-sided adhesive tape

Double-sided adhesive tape A

Back LED

Double-sided adhesive tape B

Affix so that the lead wire runs to the front of the body.

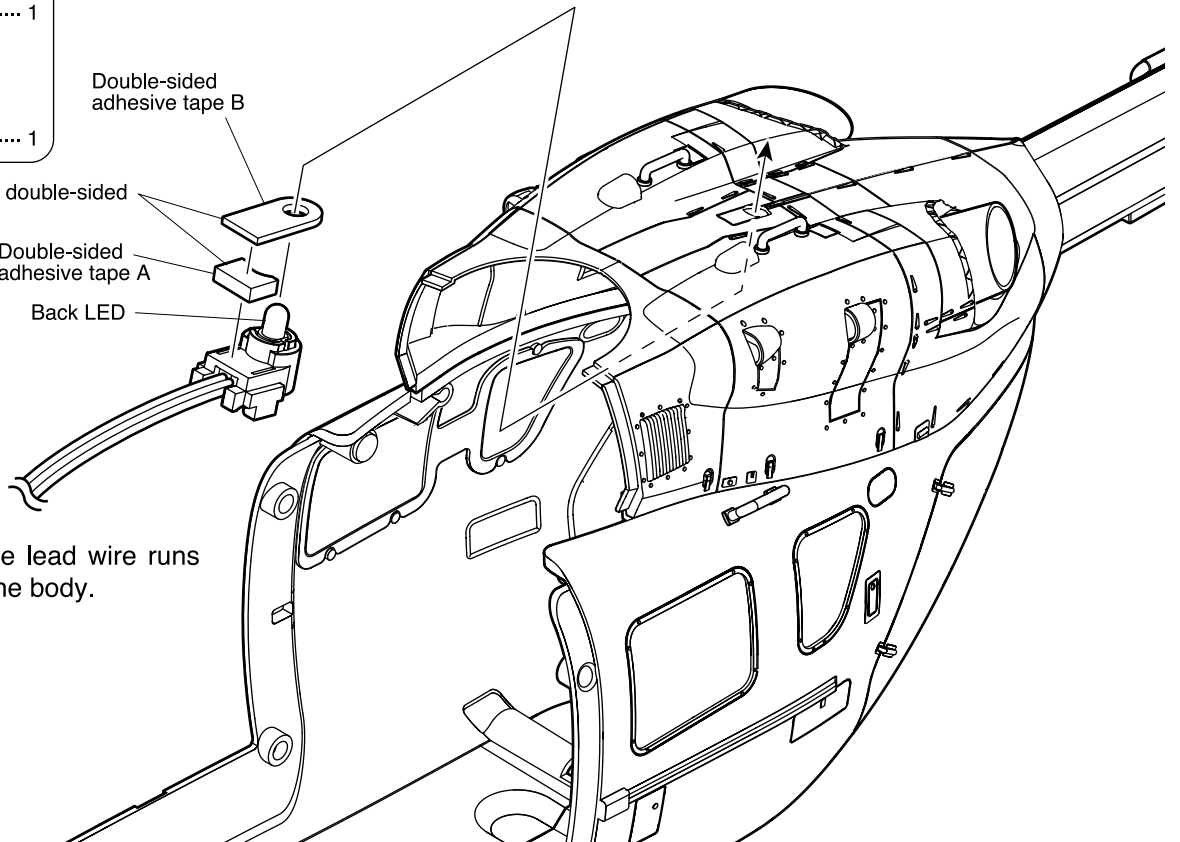

13. Body installation

⊕  M1.4X5TS 4

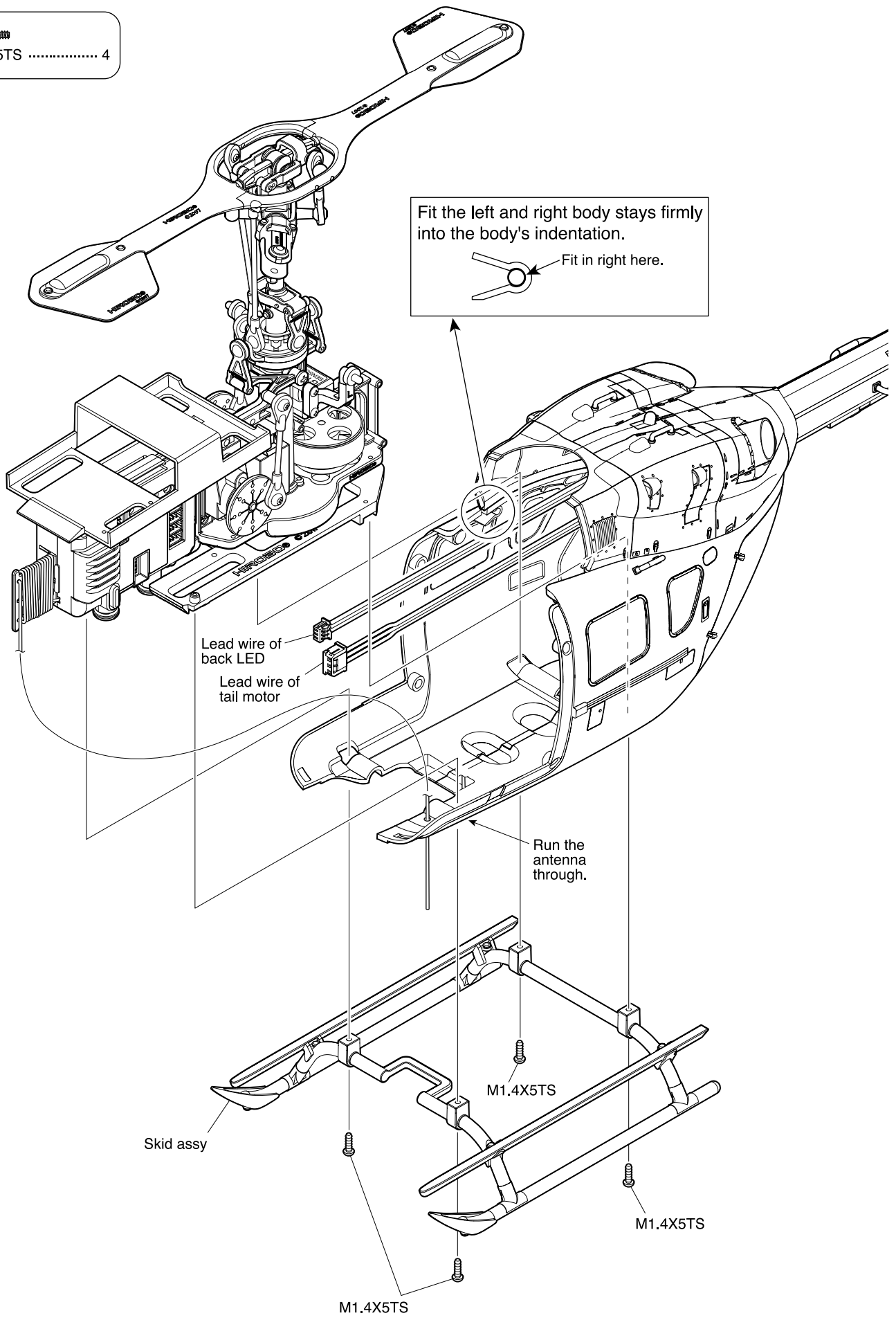

14. Connecting Tail Motor & Back LED

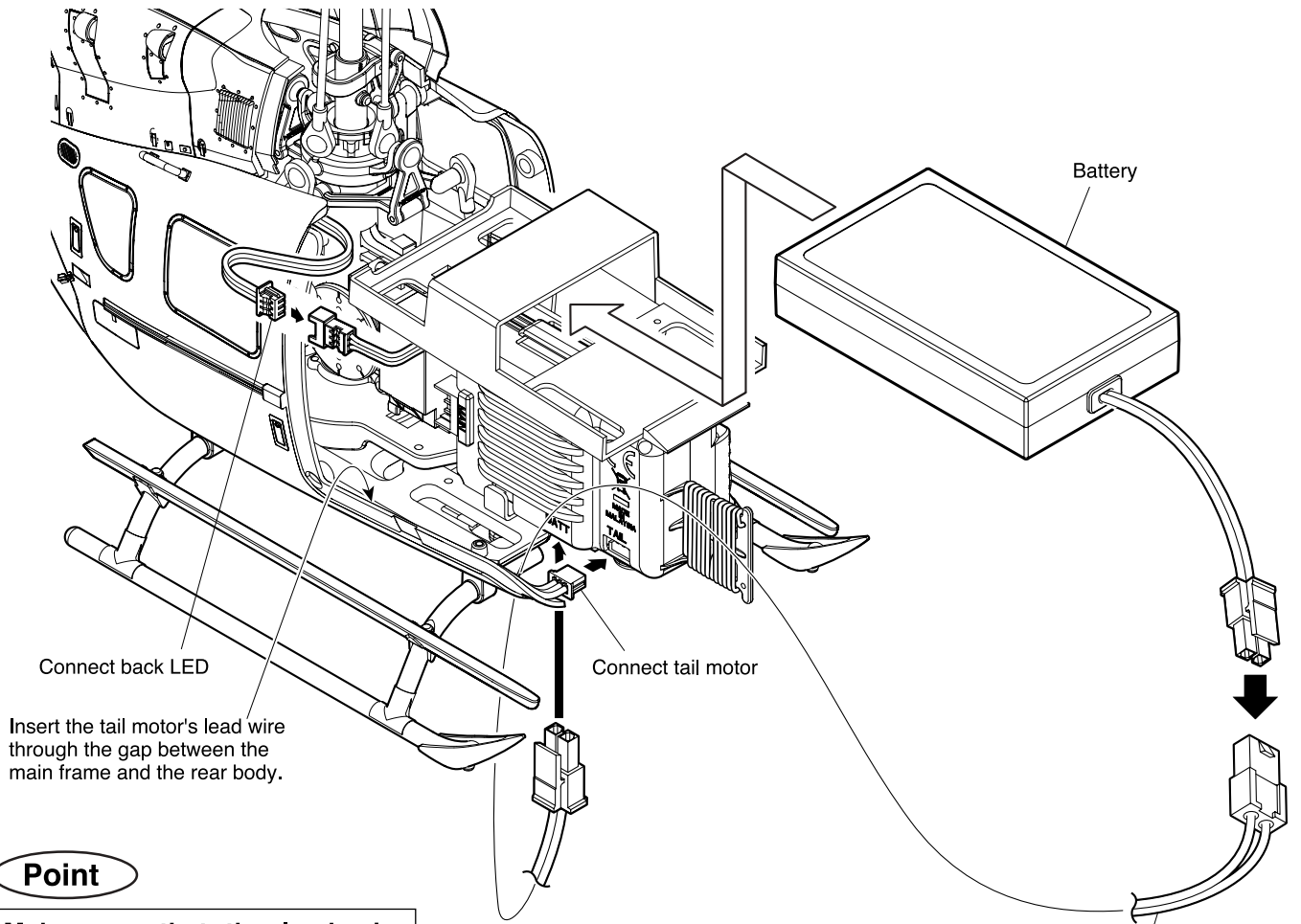

Point
 Make sure that the lead wire does not interfere with the servo, motor or other parts.

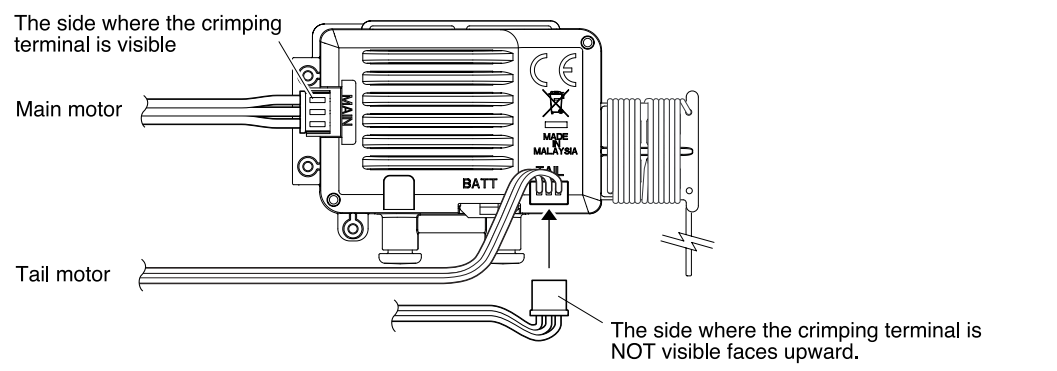

Connection Diagram

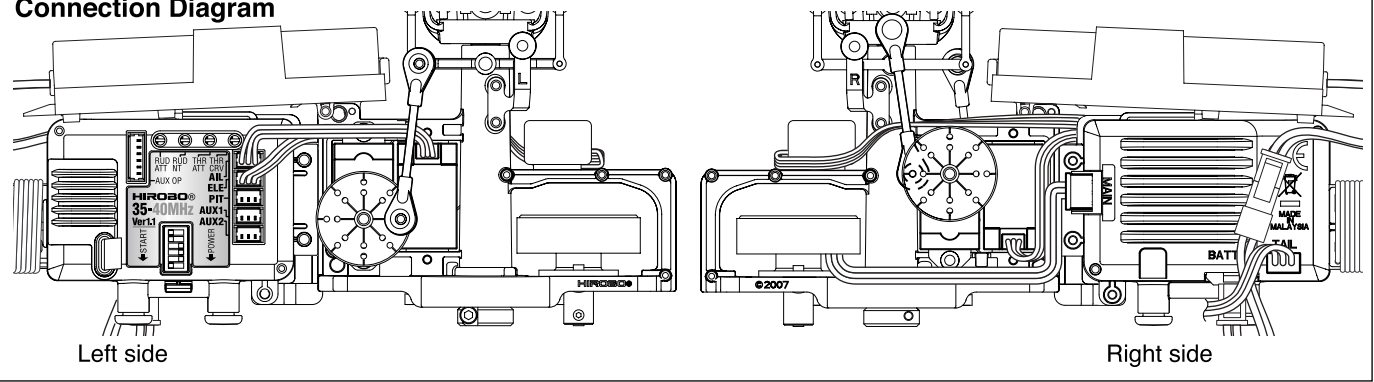

15. Front body installation

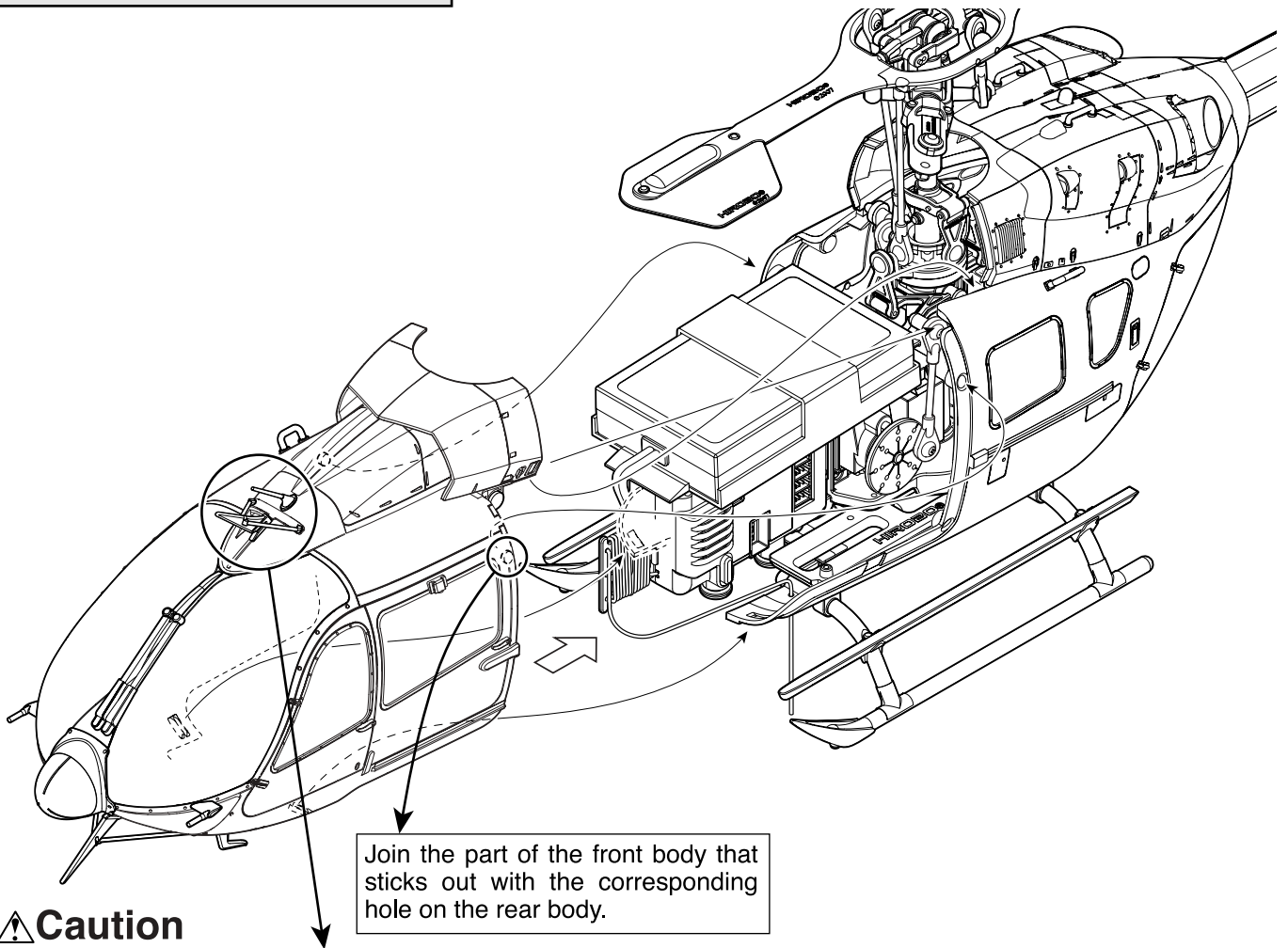

⚠ Caution

The stabilizer does not normally come into contact with the antennas, but commanding the ailerons or elevators to make big movements may cause them to come into contact when the blades are spinning slowly (e.g. right after they begin or before they stop).
Be careful not to operate the ailerons or elevators when the blades are spinning slowly.

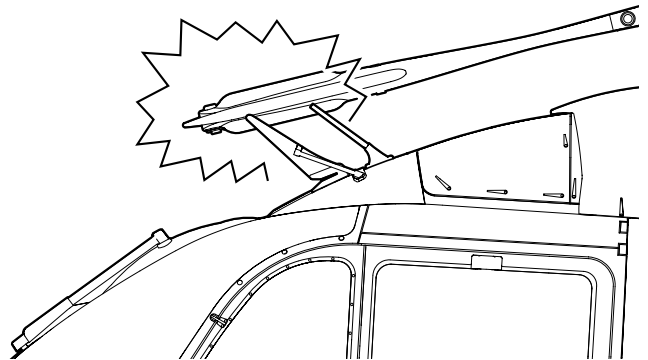

To attach

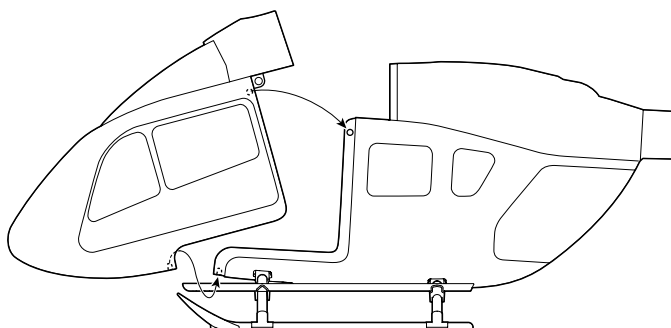

To remove

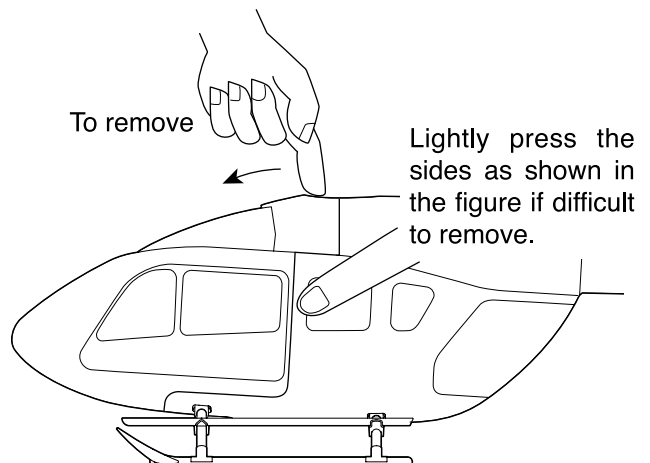

09 / Setting the Transmitter and Control Unit

1. Usable Transmitters

Settings for the transmitter and the control unit are different according to the type of transmitter.

Transmitter included in the full set product: Futaba T5YBF

Full set products are already adjusted when shipped and, therefore, do not need further setting.

In the default setting, the control unit is adjusted for use with the Futaba T5YBF.

Transmitter bought from stores

● Transmitters that can be used

Manufacturer: Futaba Corporation, Sanwa Electronic Instrument, or Japan Remote Control Co. Ltd., (JR)

Frequency: 40MHz/72MHz (Choose according to your transmitter.)

Modulation system: FM-PPM (you cannot use AM or PCM.)

Channels: At least 4 channels

- Most transmitters now on sale are computerized transmitters, and even if not all their functions are used, generally it will be possible to fly the unit with them.
- Either reset the transmitter data before use, or use a model that had not had data input into it yet.
- When initializing the unit, having the data already input into the transmitter will prevent initialization from being performed correctly, and there is a chance that the unit will not operate.
- Transmitters other than computerized transmitters, including airplane transmitters, can also be used to fly the unit.

Point

For experienced users: Settings for swash mixing and pitch curve can be adjusted through the transmitter instead of using the internal settings. Please see page 80 for details.

Point

Transmitters with four channels, that come with X.R.B or S.R.B full set, can also be used.

Point

Transmitters that use a frequency other than 40MHz and 72MHz, for example 2.4GHz, cannot be used.

⚠ Caution

- ⊘ Never use revolution mixing (tail curve).
- ❗ Always set the trim controls in the center position.
- ❗ Always set the modulation to PPM. (You cannot use PCM.)
- ❗ Always select normal type if using a swash plate type.
Futaba: HELI SWH1
Sanwa: NOR
JR: 1SERVO
- ❗ Only set the servo direction in reverse for the elevator channel.

2. Selecting the manufacturer setting

Turn the power switch on the control unit side off, and use a thin-end rod (such as the 0.89 allen wrench included with the unit) to change the control unit switches.

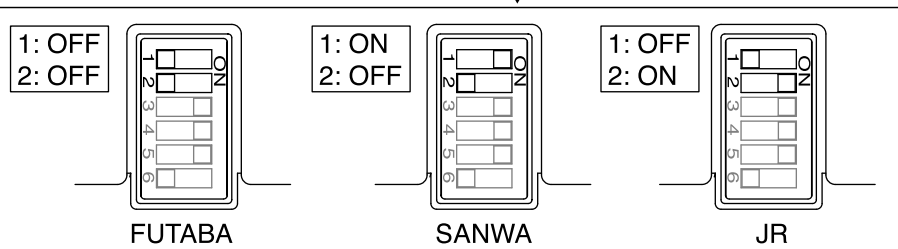
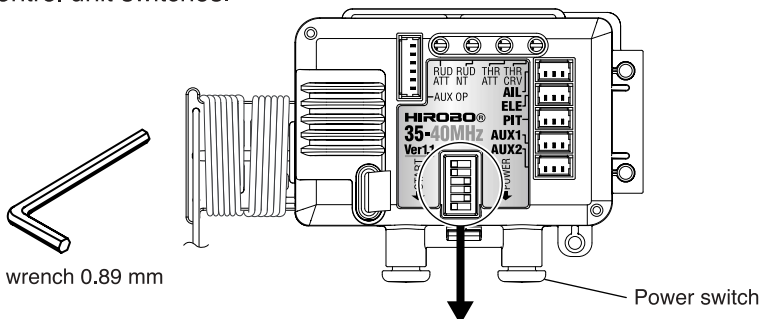

Channel setting for each transmitter manufacturer

Channel	1ch	2ch	3ch	4ch
Manufacturer				
Futaba (Initial setting)	AIL	ELE	THL	RUD
Sanwa	ELE	AIL	THL	RUD
JR	THL	AIL	ELE	RUD

Point

The transmitter selection switches are numbers 1 and 2. Note that both 1 and 2 switches must be in the correct combination.

3. Switching the Receiver Mode

* Please see P.80 for more information on the receiver mode switching function.

The receiver mode 5 is used here. Please set the switch as shown in the picture on the right.

* Receiver mode 5 is selected as the default setting.

4. Checking the operability

① How to turn on

Do not forget to turn on the transmitter before turning on the control unit.

*** DO NOT press the start switch on the control unit.**

Do not move the unit while the LED is flashing.

You can operate the servo when the LED has stopped flashing and stays

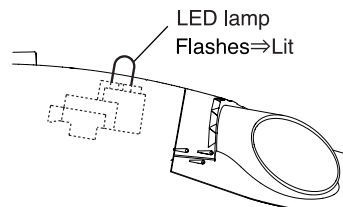
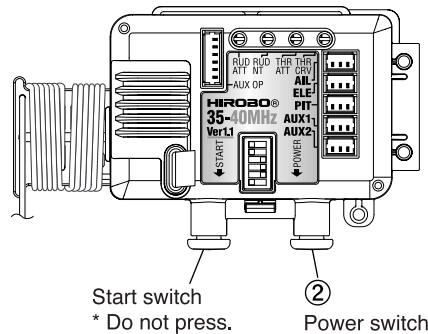
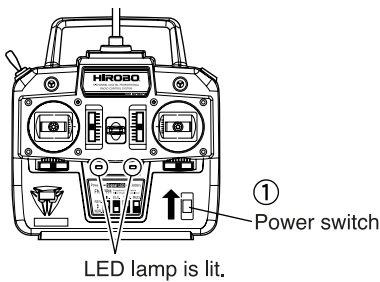

② Checking the servo operation

Check to ensure that operating the transmitter sticks moves the swash plate as shown in the diagram below.

If the allocation or movement direction of the servo differs from the diagram, reset the setting as shown in the table of "Channel setting for each transmitter manufacturer" in the previous page, according to the transmitter's instruction manual.

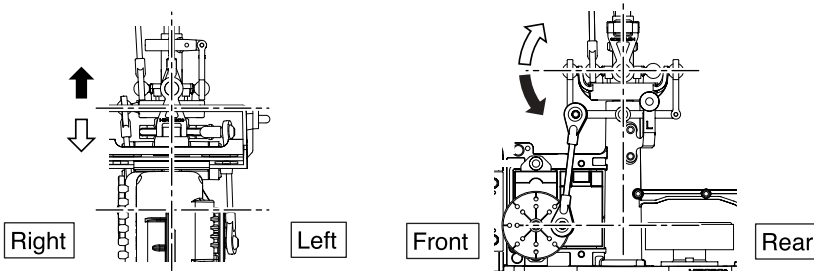

Aileron

Elevator

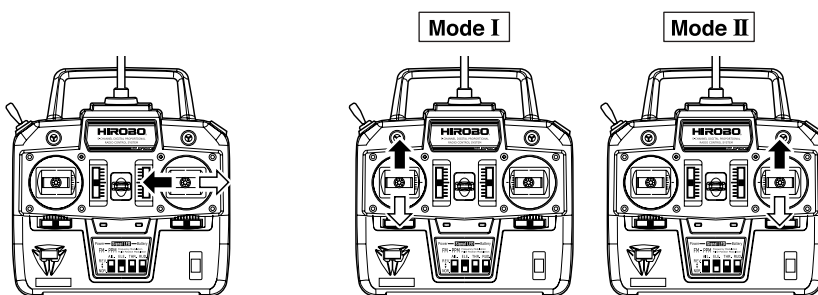

Switch on the Control Unit

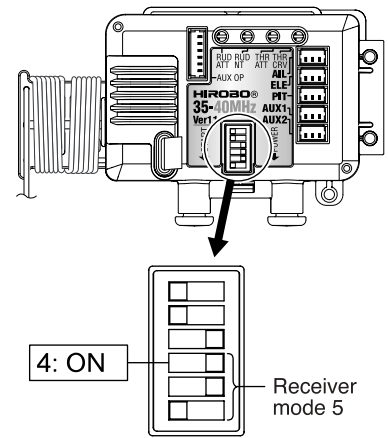

⚠ Caution

If a linkage is too long and places pressure on the servo, the servo or the control unit may be damaged when the power is turned ON. Before flight, please make sure that the servo horns are in the neutral position and the linkages are assembled correctly.

⇒ Adjusting neutral position

P.41 8-8. Servo horn installation and sub-trim adjustment

⇒ Assembling linkage

P.42 8-9. Linkage rod assembly

Point

If the LED starts flashing two consecutive orange flashes at a time and the motor sounds loud, it indicates a communication error. Refer to the page 48, and check the transmitter for the following.

1. Analog modulation (see that FM is used.)
2. Digital modulation (see that PPM is used.)
3. Do the transmitter and the receiver use the correct band?

Point

Please do not change the position of the servo horn hole.

Point

If the rudders do not move as described, there are two possible causes.

1. Channel setting is not performed according to the manufacturer of the transmitter
2. The servo may be incorrectly connected. Please check these two points referring to page 40 and 48.
3. The elevator channel is not in reverse.

5. Checking the neutral and linkage of the servo

The neutral position of the servo is already adjusted when shipped for full set products and products without the programmable transmitter.

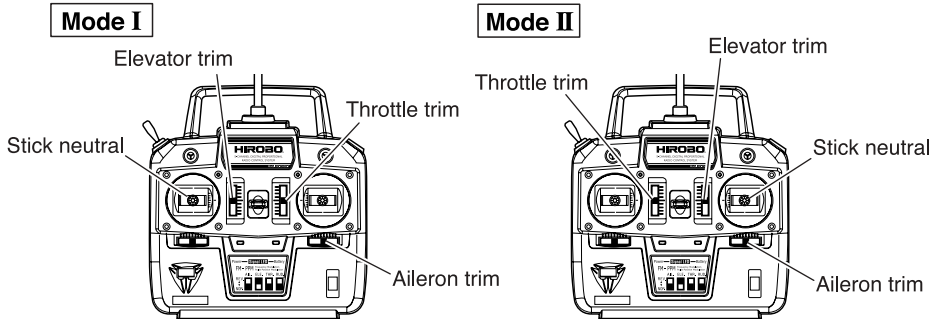

Point

Please check that the trims and sub-trims on the transmitter are in 0 or neutral.

- ① Make sure that the swash base plate, swash plate, wash arm, mixing arm and stabilizer blade are horizontal when each servo horn is horizontal to its servo.
- ② If they are not horizontal, adjust the length of each linkage rod.

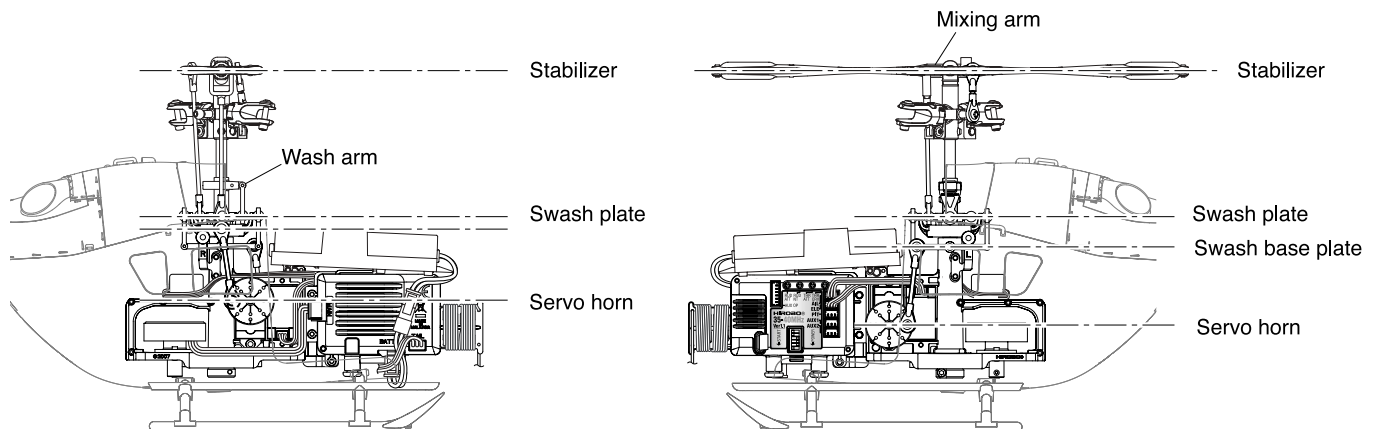

⚠ Caution

Wiggle the servos to see if any of the wiring comes into contact with the linkage rod or servo horns. Adjust the wiring configuration if there is any such improper contact.

Point

If the two servo horns are not level, refer to 08 Unit Assembly, 08-8. Servo Horn Assembly and adjust.

10 / Flight Preparations

1. Main blade installation

The main rotor blades most affect the flying performance. Not only a broken main blade, but also the adhesive tape's peeling off the leading edge, scratches, wrinkles, or a bend on the main blade can all cause the flying unit to vibrate and/or crash.

● Adjusting the balance of the main blade

Depending on whether the main blades are correctly balanced, the flight quality differs drastically. Adjust the balance of the main blades using the provided blade balancer.

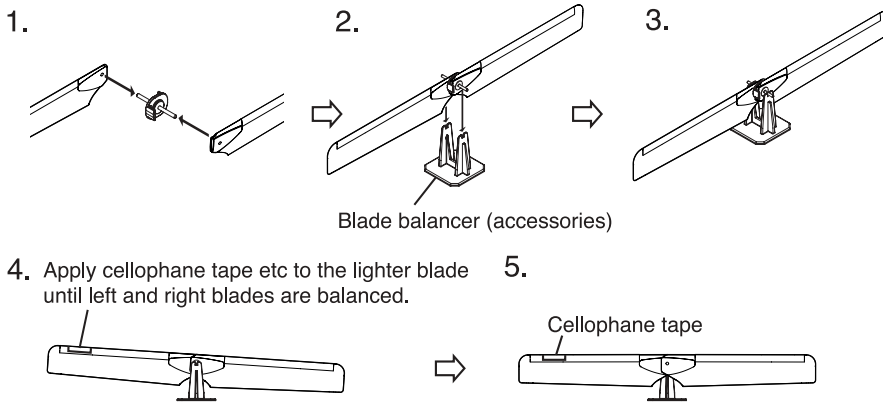

Point

- Adjusting the balance of the blades dramatically improves the hovering stability of the unit.
- If the blades are seriously out of balance, change their combination and try to apply the least amount of adhesive tape possible.

● Attaching the main blades

In attaching the main blades, both tight and loose screws adversely affect the flight performance of the unit, causing vibrations and other problems. When you attach the main blades, first gently tighten the drag bolts (tapping screw M2X10) and then loosen the bolts by one revolution, so that the main blades can move slightly back and forward.

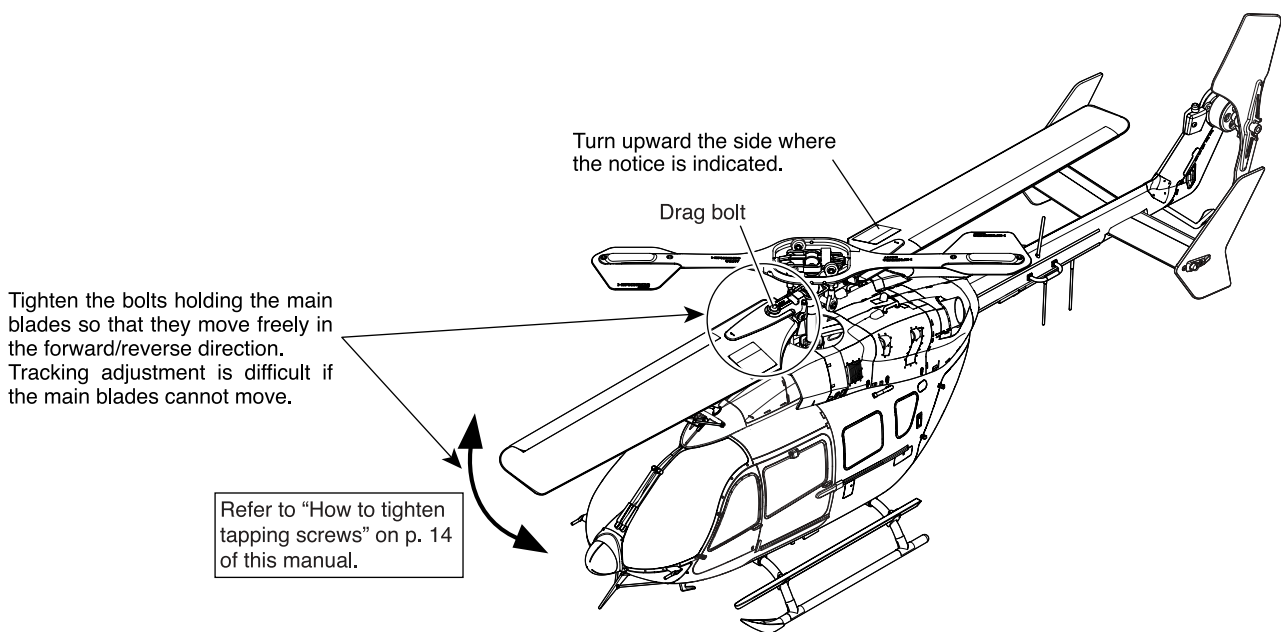

2. Tail blade installation

Please attach the tail blade in a manner so that the 'Caution' notes are clearly visible from the right of the unit. When attaching the tail blade, push firmly until it clicks into place in the tail housing.

* Please press the central plastic part of the blade. Be careful not to press the foam polystyrene parts.

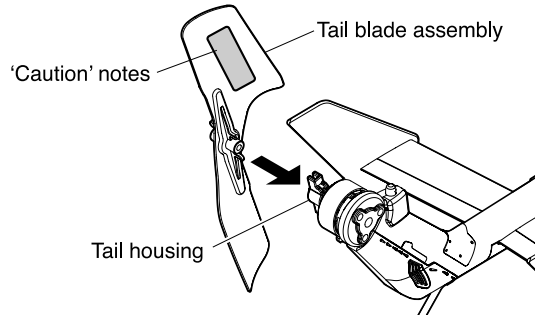

Point

Is the tail vibrating (hunting)?

If the tail vibrates side to side or sways slightly from side to side, it is possible the tail blades are out of balance. To check balance, pass the included .89 mm allen wrench through the tail blade center mounting hole and notice if one side goes up or down. If the tail blade moves, add a small piece of tape to the high side (lighter side) until the tail blade does not move when checked again. A properly balanced tail blade will lay horizontal as pictured below.

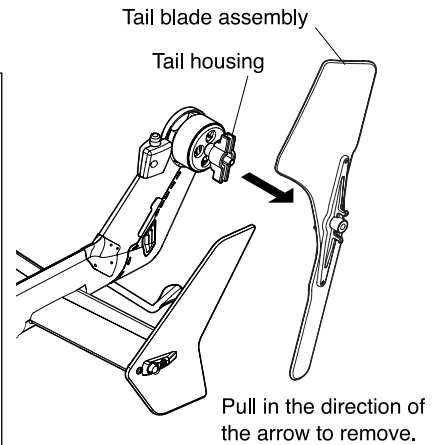
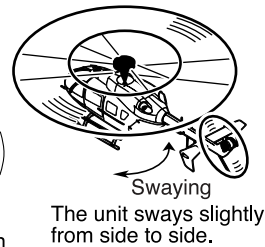
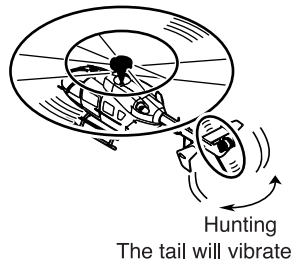
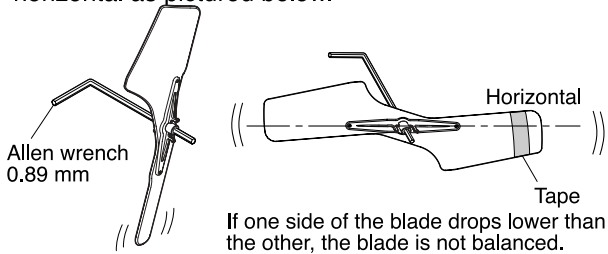

* If the tail blade is difficult to remove, use a metal flat-bladed screwdriver or similar tool to help remove it.

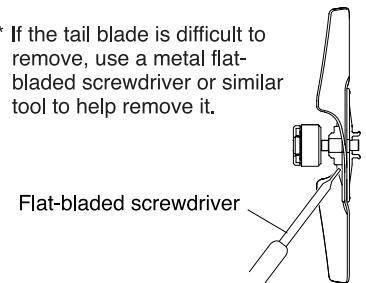

3. Installing the Battery

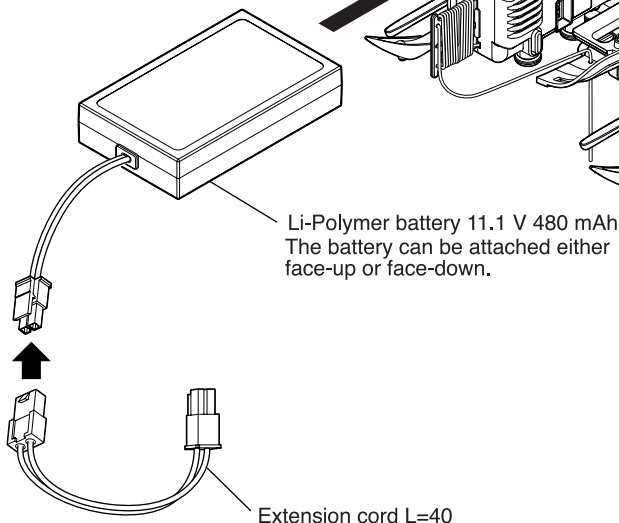
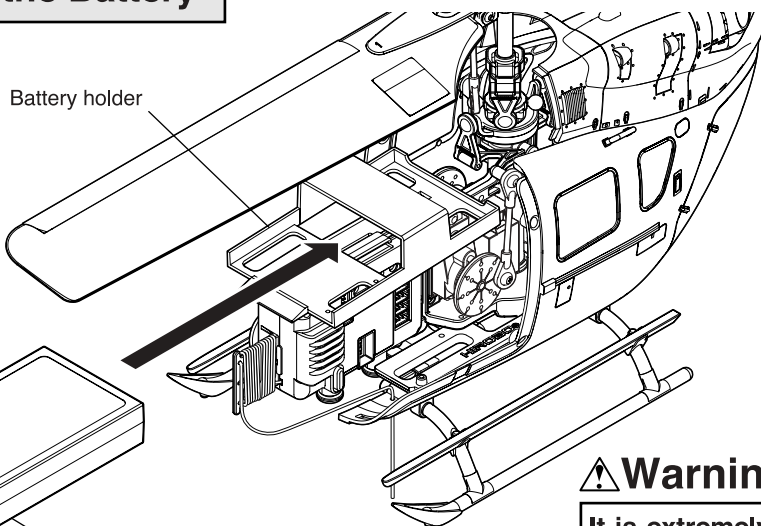

Warning

It is extremely dangerous to modify or use Extension Cord L=40 for something other than its original purpose.

Caution

To prevent over-discharging, be sure to pull off the connector when you do not fly the flying unit. With the connector plugged in, the unit continues to consume electricity resulting in over-discharging.

4. Procedure for ON/OFF Power switches

- A safety apparatus is mounted on this product to prevent malfunction from incorrect operation.

The helicopter is designed to ensure that the motor will not turn unless the switch is turned ON with the correct procedure.

Turn the switch ON with the following procedure.

- Turn the switch ON following the procedure 1. - 5 below.

- ① Set the flying unit on a flat surface.

- ② Extend the antenna of the transmitter, and turn the power switch ON.

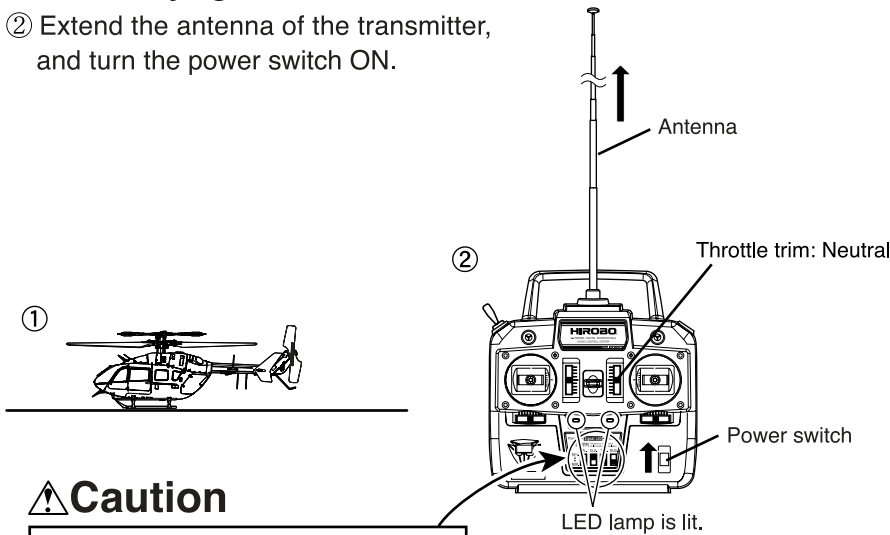

⚠ Caution

Make sure that only the elevator is set in reverse.



⚠ Caution

When turning the power switches ON, first turn the transmitter switch ON, followed by the power switch on the flying unit. When turning the power switches OFF, first turn the power switch on the flying unit OFF, followed by the power switch on the transmitter.

Point

Do not move the unit until the flashing green LED lamp turns to a constant green.

While the green LED lamp is flashing, the gyro tries to find the neutral position. If you move the unit during this period, the gyro will be unable to accurately find this position, causing an error.

* If the red and green LED lamps alternately flash on and off, it indicates that an error has occurred. If an error occurs, please turn the unit off and then switch the power back on again.

- ③ Press the power switch on the unit. (Do not move the unit until the flashing green LED lamp turns to a constant green.)

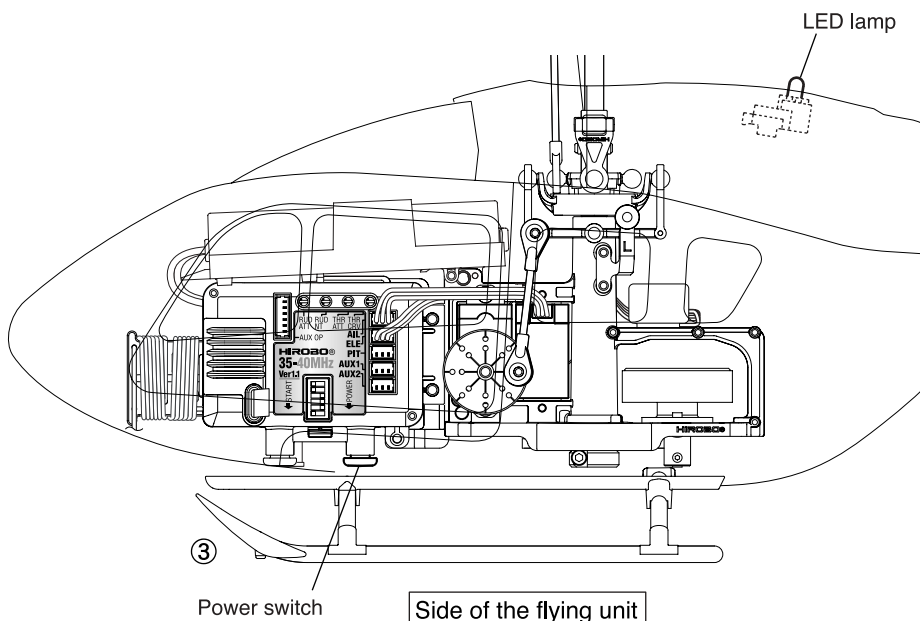

Point

If the unit is not operated within five minutes of turning the power on, it will automatically turn off.

【Turning the power off】

Before turning the power off, please disconnect the battery connector.

If the power switch is held down for longer than one second, a series of tones will sound and the power will turn off.

④ Move the throttle stick to the very bottom.

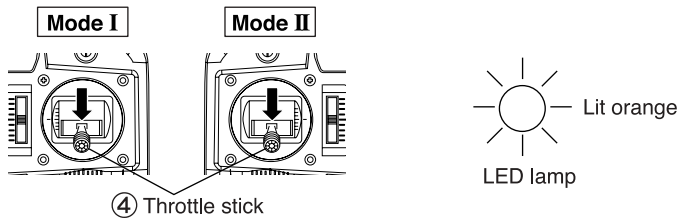

The orange LED is lit when the throttle stick is moved to the very bottom.

* The motor will not turn when the Start switch is pressed unless the orange LED is lit.

If the LED stays lit in green even when the throttle stick is in the “slowest” position, adjust it by turning the THR ATT volume adjuster to a position where the LED color becomes orange.

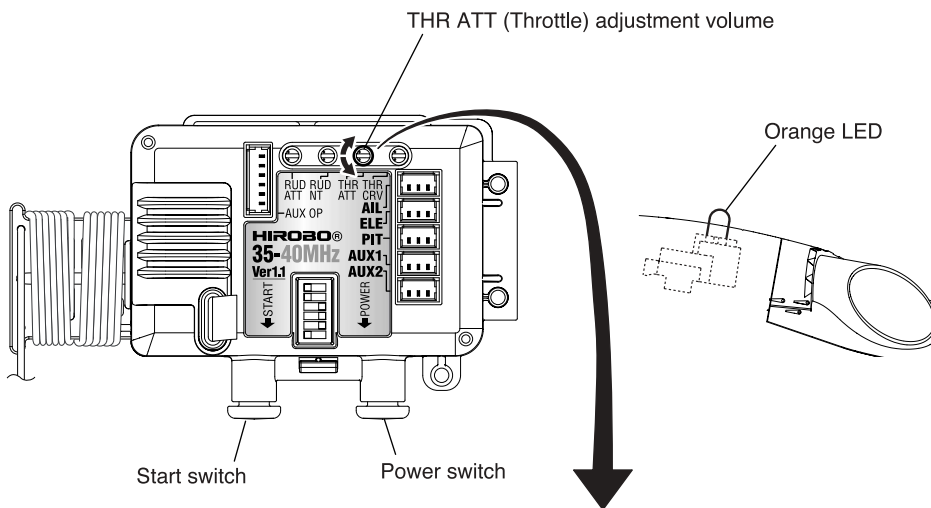

Point

You cannot disengage the safety device until the orange LED lights up.

Point

The THR ATT volume adjuster is not enabled while it is in reception mode 3 or 4. Adjust the throttle trim on the transmitter side.

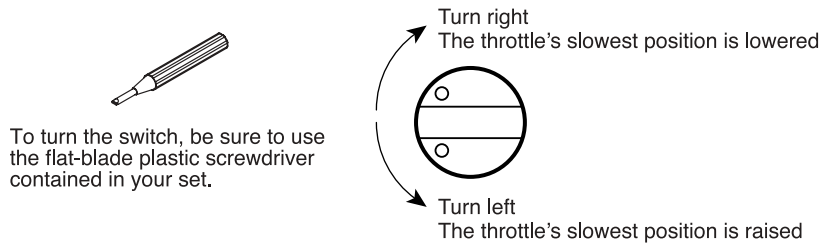

Raise the throttle stick, and check that the orange LED has turned off. The stick position at which the orange LED turns green is the position at which the motor starts.

⑤ Press the Start switch.

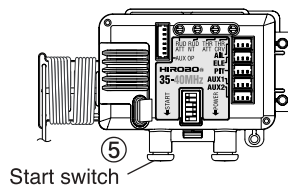

The LED light will turn green to indicate that the unit is ready for flight.

With the transmitter throttle stick in the slowest position and with the orange LED on the control unit on, pressing the start switch will disengage the safety device and allow the motor to start.

5. Tracking adjustment

● Adjusting the Tracking

When turning the main blades, adjust so that they both trace the same path and appear to overlap. This is referred to as "tracking adjustment". Vibration will occur, having a negative effect on flight, if the blades do not track correctly.

Adjustment required if blades appear like this when rotating the main blade

Determine whether the marked blade is above or below.

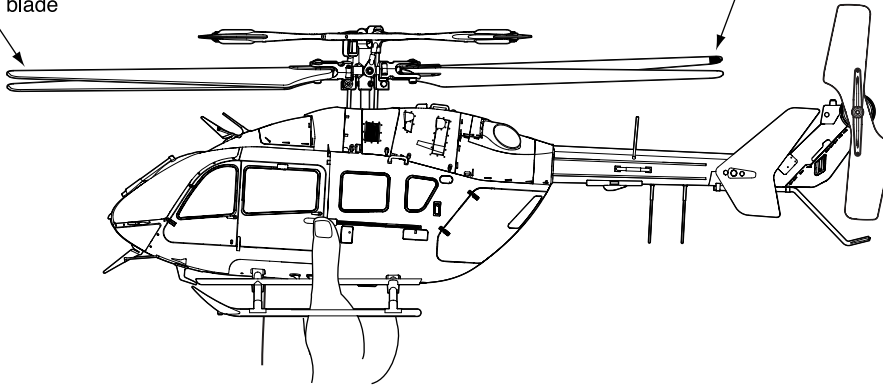

Point

Make a mark on the edge of one main blade with a red felt-tip pen or something similar.

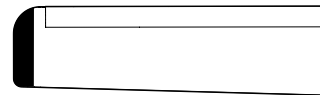

<Adjusting main blade tracking>

Adjust the length of the pitch rod so that, when the rotor is turned, the pitch angle of the blade which appears to be above is small, and the pitch angle of the blade which appears to be below is large.

Mark the main blade whose pitch rod is in the direction of rotation (forward edge side).

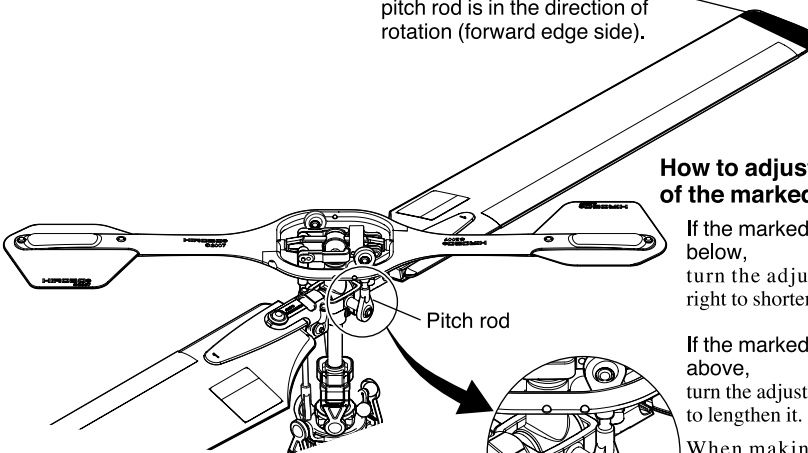

How to adjust the tracking of the marked blade:

If the marked blade appears below, turn the adjusting rod to the right to shorten it.

If the marked blade appears above, turn the adjusting rod to the left to lengthen it.

When making adjustments, turn the adjusting rod a half or one revolution at a time, and find the location where the tracking matches the marked blade.

Longer
Shorter



Threaded - turn to right to shorten, to left to lengthen.



Make sure that the rod ends are mounted at a 40° - 50° angle to each other or the stabilizer will not operate properly and the helicopter may crash.

Point

【Note about the rod end】

The rod end functions as a joint. When you attach it, be sure it clicks and correctly fits to the ball. If it is out of position or pressed too far inside, the rod end cannot function correctly resulting in a crash.

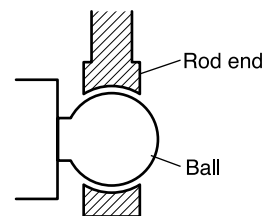

Sectional drawing

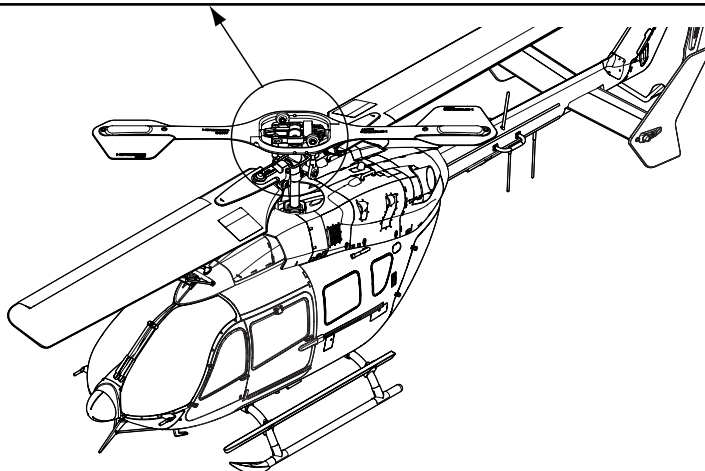

6. Adjusting the rotation speed of the main blade

This section describes how to adjust the rotation speed of the main blade by adjusting the main blade pitch.

With the S.R.B., you can check the rotation speed of the main blade while hovering by looking at the LED display.

Confirm that the appropriate rotation speed has been reached before adjusting.

The rotation speed of the S.R.B.'s main blade while hovering is around 2,150 to 2,400 rpm. The LED will turn orange once the speed is within this range.

[Procedures]

- ① Turn on the power of the transmitter.
- ② Place the unit on a flat surface, and turn on the power switch. Do not move the unit until the flashing green LED turns to a solid green.
- ③ Press the start switch (with the transmitter throttle stick at the lowest position). Hold the unit in your hand and gently increase the throttle speed until hovering speed is reached and a rotation speed, where the unit is just able to lift itself, is reached.

When the rotation speed is right:

The orange LED will light up. → This indicates the right rotation speed has been reached, and there is no problem.

If the orange LED does not come on even though the hovering speed has been reached, stop the unit and adjust the pitch angle adjustment screws of the two main blades by turning each of them by the same number of rotations.

When the rotation speed is too high:

If the orange LED turns on and then off before hovering speed is reached, it indicates that the rotation speed is too high.

→ In such cases, adjust the pitch angle by turning the pitch angle adjustment screw to the right to reduce the rotation speed.

When the rotation speed is too low:

If the orange LED does not flash or turn on even once, the rotation speed is too low.

→ In such cases, adjust the pitch angle by turning the pitch angle adjustment screw to the left to increase the rotation speed.

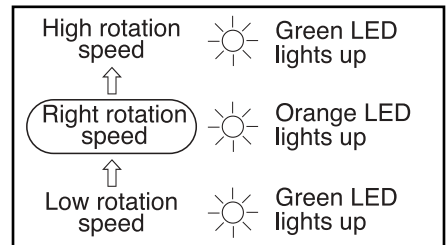
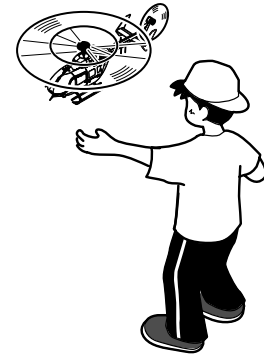
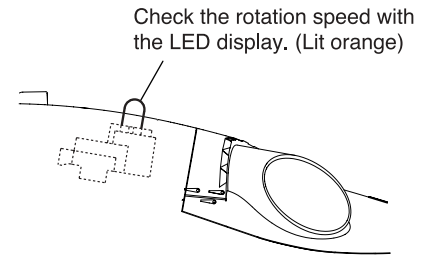
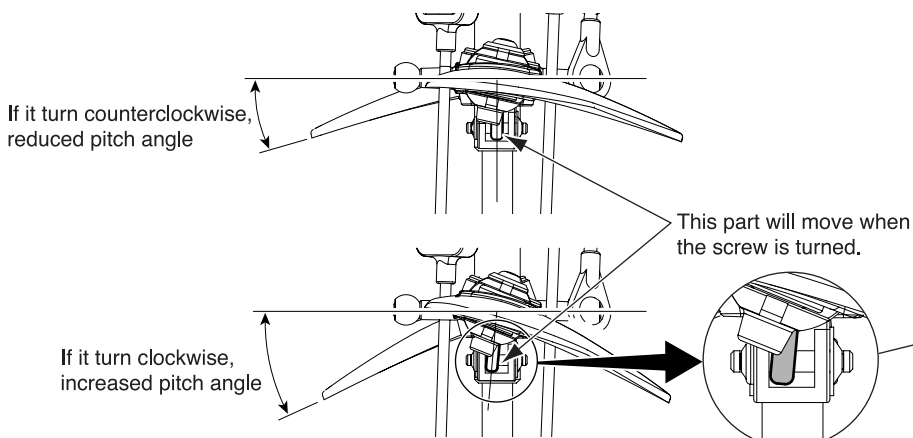
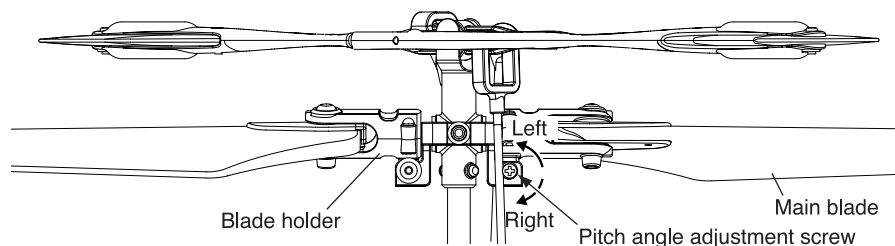

Point

Be sure to turn equally both of the two pitch angle adjustment screws. Use the Philips screwdriver.

Caution

Do not turn the pitch angle adjustment screws too tight. If you do, you can damage their threads. Moreover, please note that they are fixed with a special kind of nut known as a lock nut so that they cannot be disassembled.

Point

If the pitch angle adjustment screws of the two main blades are turned by different amounts of rotations, the tracking will be out of position. If you are unsure of the tracking, check this area to see if they are both at about the same angle, and readjust them until both appear to be at the same angle.

11 / Flight Practice

1. Preflight Inspection

● Are the servo and motor operating correctly?

The safety lock is not cleared, and the motor will not turn, if the throttle trim is at the top of its range. If the servo moves but the motor does not turn, set the throttle trim to a position below neutral, and turn the switch ON again following the correct procedure.

If the safety lock is not cleared by adjusting the throttle trim, check whether the throttle reverse switch is set correctly. See page 9 for details, or read the instruction manual for the transmitter.

If the transmitter throttle trim is at the top of its range, set it to a position below neutral.

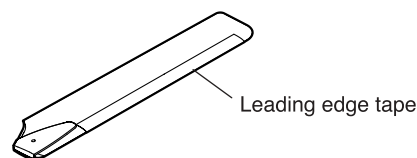
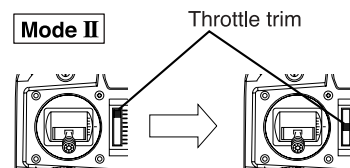
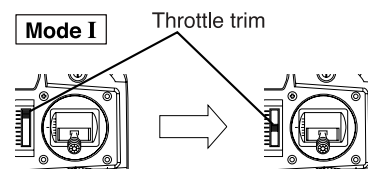

● Is the leading edge tape on the main blades peeling?

White tape is attached to the leading edge of the main blades.

Any lifting or peeling of this tape will have adverse affects on flight characteristics, and it should therefore always be checked before flight by pressing it lightly with the fingers.

* Any lifting of the tape will increase the amount of vibration.

● Is the transmitter antenna extended?

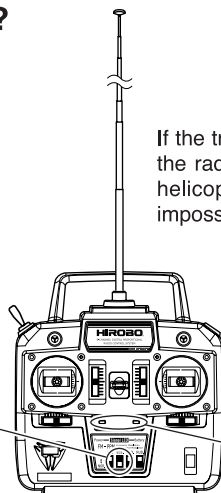

If the transmitter antenna is not extended, the radio transmissions will not reach the helicopter, and control may become impossible. Always extend the antenna.

● Is the elevator in reverse?

If the remaining battery power indicator's color turns from green and starts flashing red, change the batteries.

● Is sufficient power remaining in the batteries?

The radio transmissions become weaker as the batteries discharge, and control may become impossible. Check the battery level display, and replace the batteries if necessary.

Stick operation must become second nature. Think of learning to ride a bicycle for the first time. Once you have learned how, you no longer have to think about which way to move the sticks. Your body just does it automatically. Practice using the sticks until you no longer have to think about it.



Place the helicopter on a flat floor. The operator should stand at a distance of 1-2 m behind the helicopter.

By standing behind, you can face in the same direction as the helicopter. It is easier to understand direction of helicopter.

Point

- Stand behind the flying unit.
- Secure the largest flight area possible.

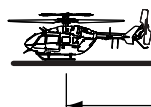

〈The correct way to hold the transmitter〉

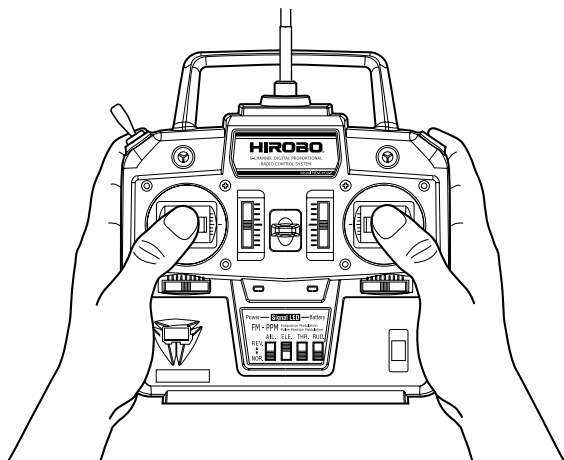

Place both of your thumbs on the ends of the sticks.

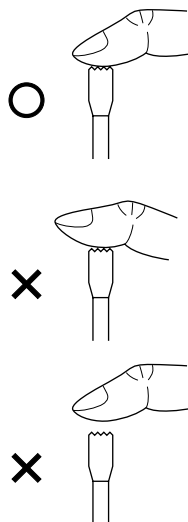

Point

Place the tips of your thumbs on the sticks.
If you control the sticks with the balls or the sides of your fingers, you cannot respond when a quick movement is necessary.

【Fail-safe feature】

If the battery runs low during a flight or the flying unit stops receiving a signal, then the throttle will automatically and gradually slow down. If this occurs, please land the flying unit immediately.

If the voltage of the battery drops lower than the required level, the LED starts pulsing in orange (slow). The flight can be continued for one minute after the LED starts pulsing. Please land the unit within this time. After one minute, the throttle is automatically shifted to slow. Also, if the unit is not successfully receiving signals, the LED starts pulsing two consecutive flashes at a time, and the throttle is automatically shifted to slow.

⚠ Caution

Both main / tail motors are outrunner motors.
Do not touch them while they are rotating.
The motor or the control unit may be damaged if the rotation of the motor is forcibly slowed down.
Ensure that there is no string, or a similar object, tangled to the motor and that the inside of the motor is clear of foreign object such as small screws.

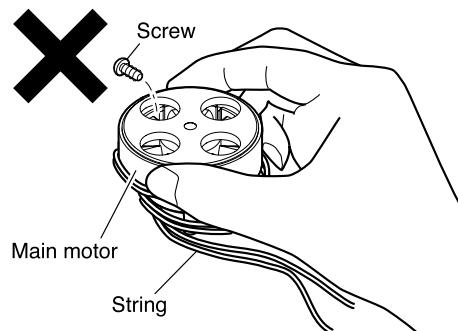

⚠ Caution

Do not run the helicopter continuously for more than 8 - 9 minutes (the maximum time for one battery). Since overheating of the motor may negatively affect performance and the life of the product may be reduced, wait for five minutes between each flight.

Point

Be sure to charge the battery as soon as your flight is over.



**Do not fly the model continuously.
Continuously flying the model will dramatically shorten the life of the motor.**

Although the S.R.B. EC145 uses a compact and light-weight high-performance brushless motor, continuous operation exerts a load on the motor and causes its temperature to increase.

Using the motor while it is hot dramatically shortens its life.

Using the spare battery and flying the model on two batteries one after the other may cause the motor temperature to increase. After flying the model with one battery, allow enough time for the motor to cool down before flying the model again.

2. Taking off a single-rotor helicopter

In the case of a single-rotor helicopter, then the unit will not rise vertically when the throttle is raised. When taking off, the unit will attempt to rise on a slant to the left of the aileron. Accordingly, the aileron will need to be pushed to the right during take off.

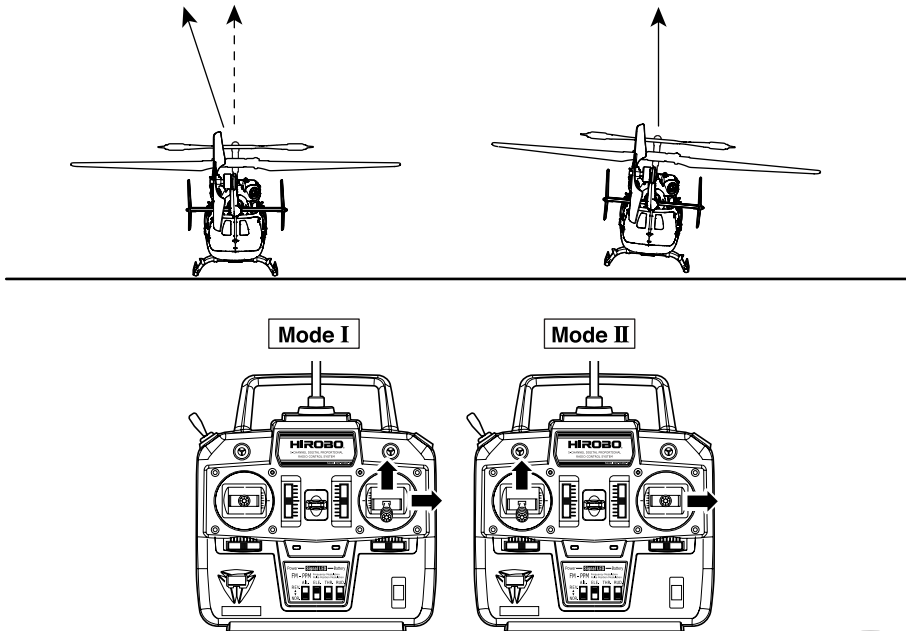

Slowly bringing up the throttle stick will cause the flying unit to drift to the left of the aileron. You need to practice pushing the aileron to the right to make the flying unit rise vertically upwards. Please note that the flying unit hovers slightly on a slant to the right of the aileron.

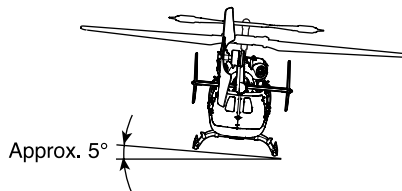

Point

Tail rotor drift (horizontal sliding) occurs with single-rotor helicopters. To eliminate this tendency, the flying unit hovers on a slight angle.

Notes on general single-rotor helicopters

Single rotor helicopters generally use tail-rotor lift in order to eliminate torque. This type is easy to build and provides excellent flight characteristics, and therefore it is now the most common type of helicopter.

Radio-controlled helicopters are often called upon to fly at high speeds or do stunts, so most use this system. However, with single-rotor helicopters, the lift from the tail causes the flying unit to drift (slide sideways), so it is necessary to incline the flying unit on a slight angle during hovering in order to keep it stable in the air.

It is likely that the control of the tail rotor is the main reason why helicopters are said to be difficult to control.

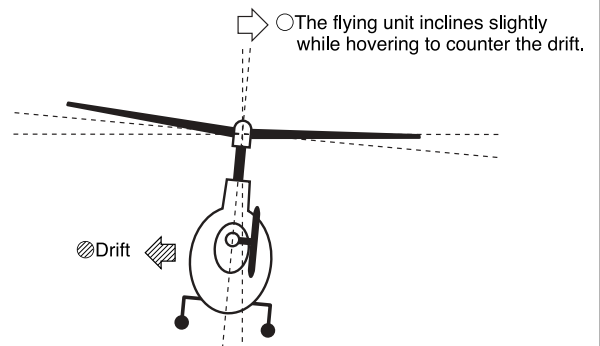
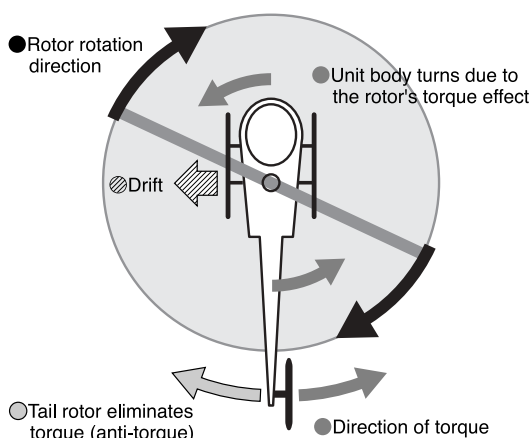

- Rotor rotation direction
- Unit body turns due to the rotor's torque effect
- Tail rotor eliminates or controls torque.
- ▨ Tail rotor effect causes drift
- Incline slightly while covering to counter drift

3. Aileron and elevator trim adjustment

- Adjust the trim if the flying unit moves forward/reverse or left/right without operation of the stick.
Adjust the trim by using the trim lever on the transmitter.

<Fixing forward/reverse movement>

- If the flying unit makes an unwanted move forward, move the elevator trim lever down. (The black arrow in the drawing)
- If the flying unit makes an unwanted move backward, move the elevator trim lever up. (The white arrow in the drawing)

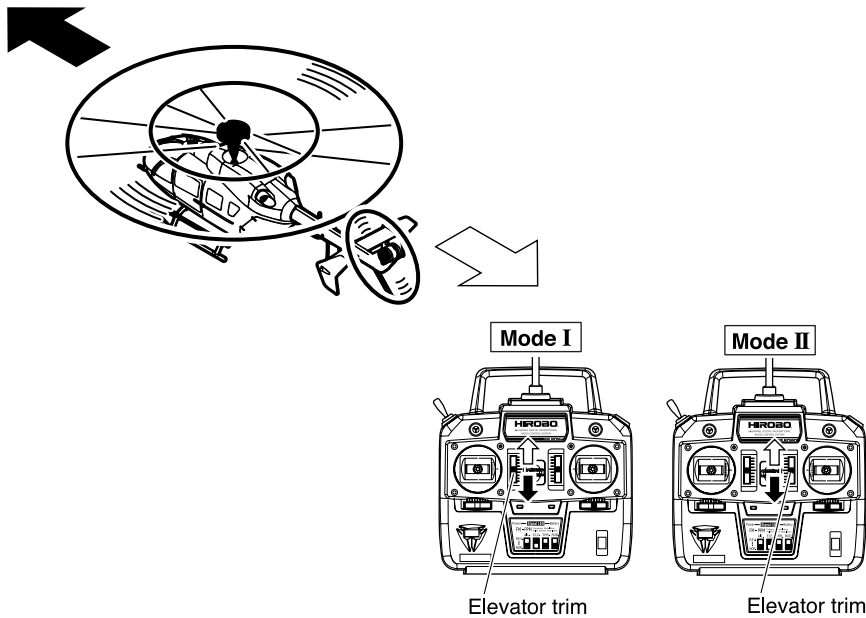

Point

Raise to knee height to adjust trim.

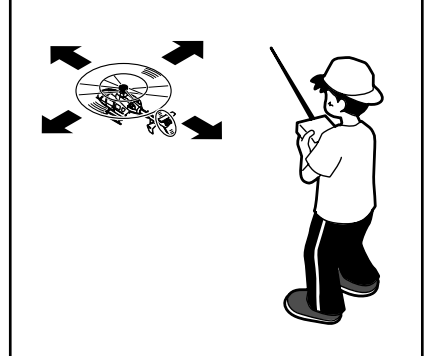

<Fixing left/right movement>

- If the flying unit makes an unwanted move to the right, move the aileron trim lever left. (The black arrow in the drawing)
- If the flying unit makes an unwanted move to the left, move the aileron trim lever right. (The white arrow in the drawing)

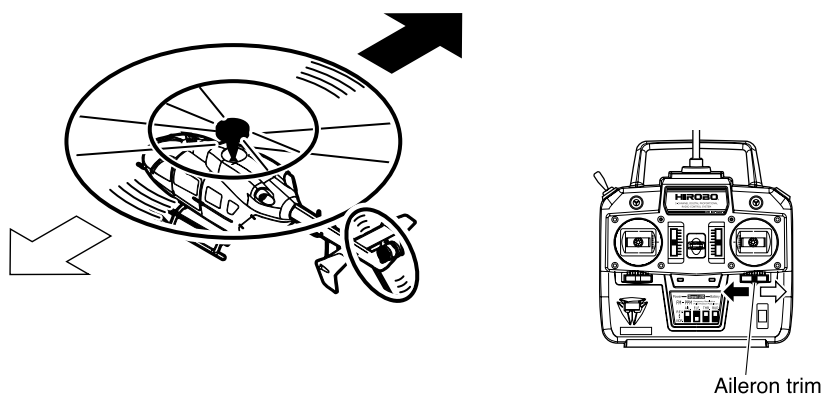

4. Rudder trim adjustment

If the flying unit turns to either the left or right while hovering, you need to adjust the rudder trim. Do not adjust the rudder trim by using the rudder trim on the transmitter. Leave the rudder trim on the transmitter in the central (neutral) position. Turn the rudder neutral adjustment volume on the control unit to adjust the trim.

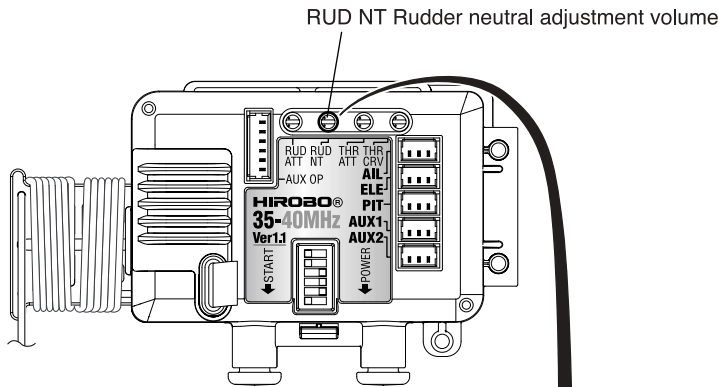

Point

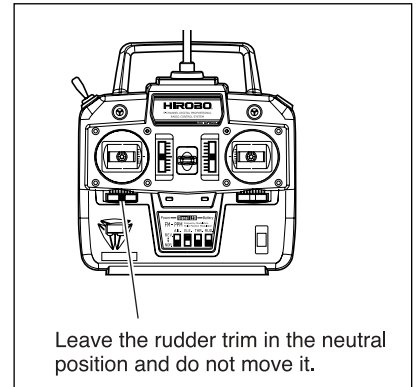

If the flying unit turns to the right, adjust the volume to the left.

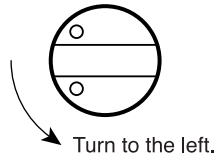
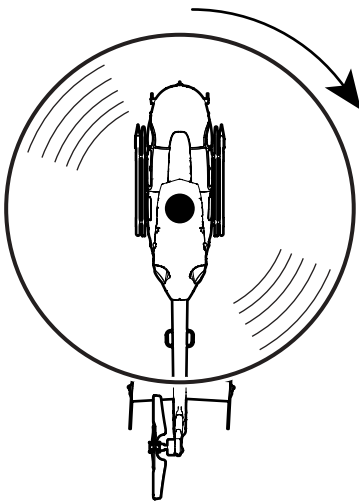

【If the rudder deviates from neutral after several minutes of flight】

The rudder is equipped with a gyro, but because of the vibration on the unit, it may deviate from the neutral position. In such cases, turn off the power and then turn it back on again. The unit will again try to find the neutral position.

If the flying unit turns to the left, adjust the volume to the right.

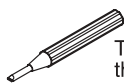
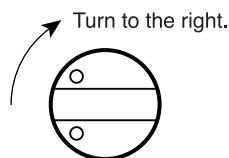
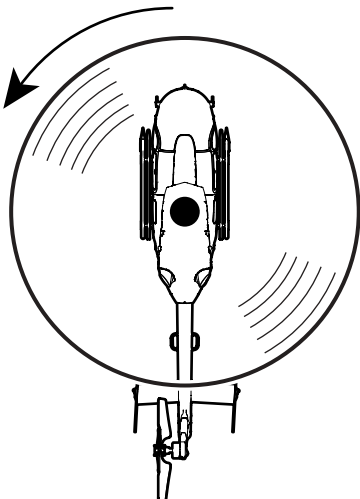

To turn the switch, be sure to use the flat-blade plastic screwdriver contained in your set.

5. Throttle stick operations practice

First of all, you need to learn how to use the throttle stick in order to make the flying unit ascend and descend.

A helicopter does not descend on its own power, but can be controlled by adjusting the ascending force.

● Practice

- Stand behind the flying unit and bring up the throttle stick slowly.
- As you move the throttle up, the rotor accelerates its rotating little by little.
- When the unit lifts up off the the ground a little, make it come down. Repeat practicing these ups and downs over and over again.
- Do not let the unit touch down hard on the ground. Make it land smoothly and gently.

Practice increasing rotor speed until just before lift-off, then reducing it.

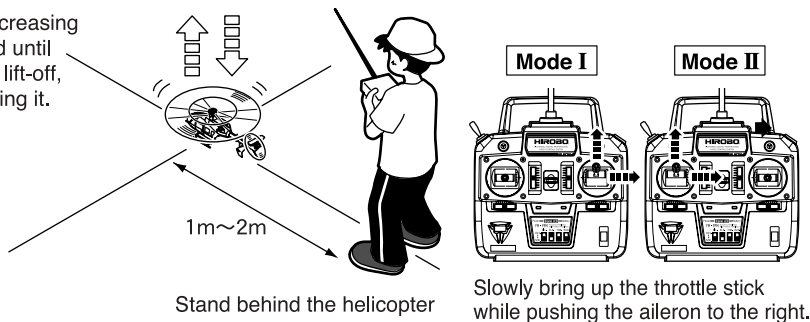

⚠ Caution

During take off, if the main motor and the tail motor do not rotate smoothly when the throttle stick on the transmitter is pulled up, lower the throttle stick and start again.

If motor is forced to turn, it may damage motor or control unit.

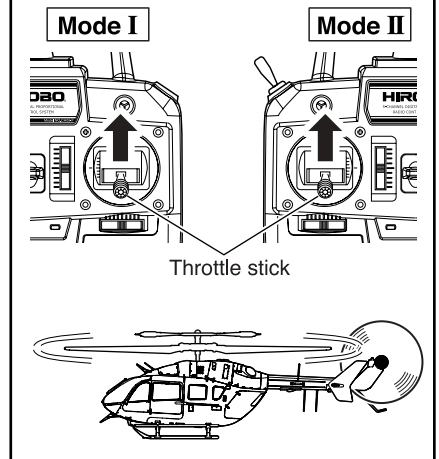

⚠ Caution

If the helicopter crashes or topples over on its side, quickly lower the throttle stick to stop the motor turning. Otherwise, when the blades hit the ground, the helicopter could thrash about causing a lot of damage including broken parts.

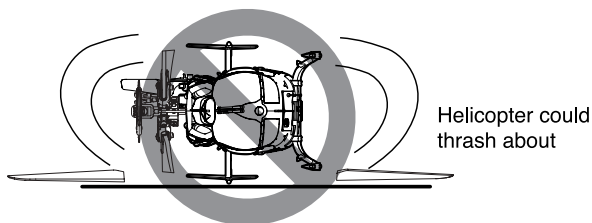

Point

- If the flying unit escapes your control, bring it back under control by pushing the aileron to the right. If this does not correct the problem, do not give up, but rather bring down the throttle stick, land the unit, and return it to the original position and facing before trying the practice again.
- The earth's gravity pulls the unit downward. While ascending needs power, the helicopter's descending is powered by this natural gravity. When you want to bring the unit down, never suddenly bring the throttle stick all the way down while the unit is in the air. This will result in a crash.

One point Wind from the rotor

When hovering up to 30cm above the ground, the helicopter is affected by its own rotor wind, and becomes unsteady. This is referred to as 'ground effect', and while it has the benefit of facilitating lift, it requires care with a lightweight helicopter.

As you get used to this up-down practice and find it hard to make the unit fly slightly above the ground, take the courage to make the unit fly to the level of your knees. You will see that the unit's posture is stabilized and find it easier to operate the unit.

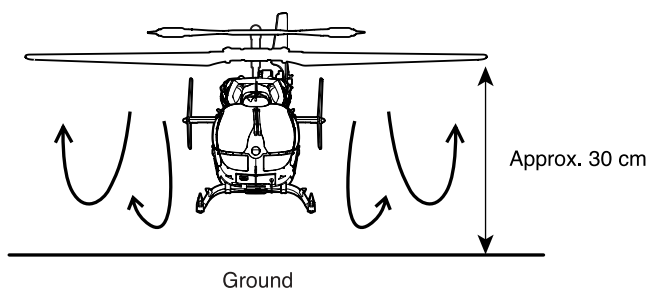

【Ground Effect】

Generally, a helicopter experiences the ground effect when its altitude is approximately below its rotor's diameter.

6. Practicing rudder operation

Now, in addition to the throttle operation you practiced earlier, try operating the rudder. "Rudder operation" means turning the flying unit's nose left or right.

● Practice

- Try several times a sequence of operations such as "Lift off and left rudder" → "Land" → "Lift off and right rudder" → "Land," in order to confirm that you can make the flying unit turn left and right.

<Practicing rudder operation>

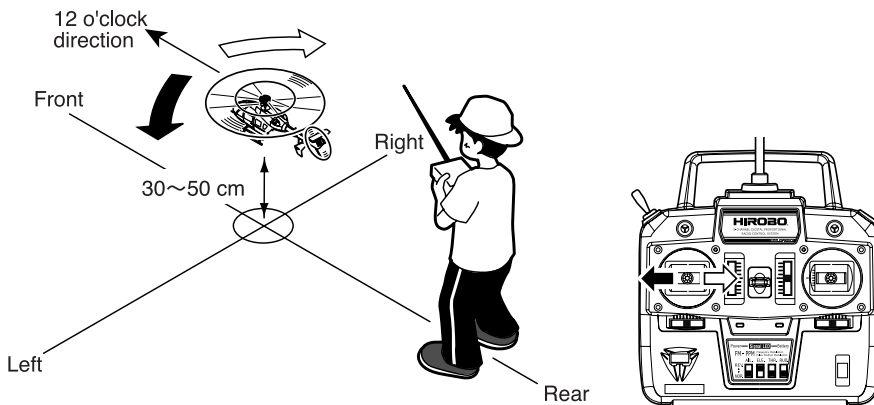

Point

- It is a little difficult to make the unit lift off with its nose heading right or left. If you find this hard to do, set the nose to the 12 o'clock direction after landing and resume the practice.
- Do not watch the flying unit's tail as you operate the unit. This can often lead to operational errors. Pretend you are in the helicopter's cockpit and watch the unit's nose.

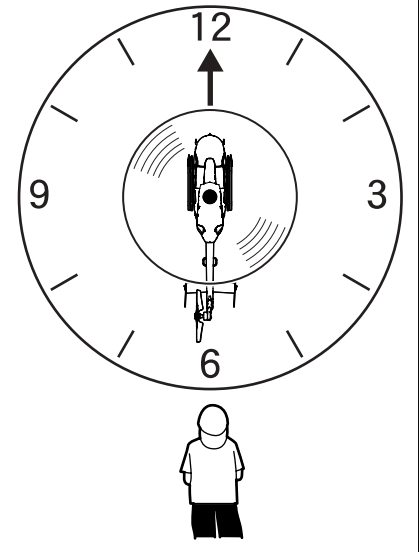

⚠ Caution

- If the flying unit has drifted away from its original position, fetch it after it has landed and bring it back to the original position.
- You need to practice well the rudder operation because it is important to set the nose and the pilot in the same direction.
- In principle, the nose should be in the 12 o'clock direction.

One point Rudder Characteristics

For the S.R.B, anti-torque created by the rotation of the main blade is offset by the rotation of the tail blade (tail motor) to keep the unit balanced.

Also, left/right rudder is controlled by changing the rotational speed of the blades.

Right rudder is produced by creating a thrust force, which is greater than the anti-torque, at the tail blade.

Left rudder is produced by reducing the rotational speed of the tail blade so that the thrust force is less than the anti-torque.

When the anti-torque is small, which is when the rotational speed of the main blade is low and so is the pitch, such as when making a steep dive by lowering the throttle stick in the normal mode, the thrust force also has to be small to keep the balance, so the rotational speed of the tail blade is the lowest.

In this case, left rudder cannot be produced by the anti-torque. Lower the height slowly so that the rotation speed of the main blade is not too reduced. In this way the unit can be steered to the left as usual.

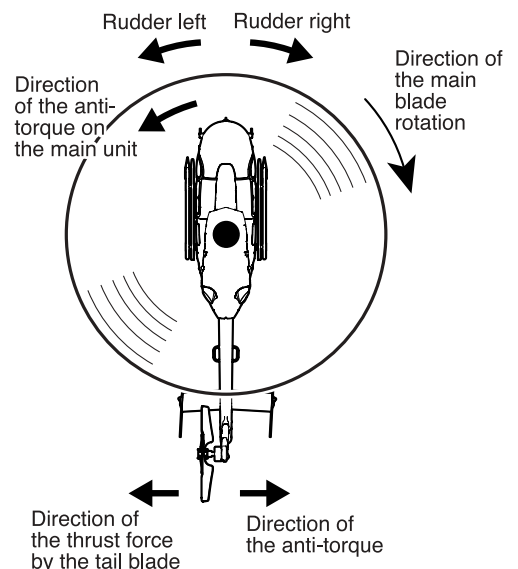

7. Practicing hovering

First, practice making your S.R.B hover just above the heliport without allowing it to move out.

● Practice

- Make your S.R.B fly off the heliport to the level of your waist.
- If the flying unit begins to drift, use either the “aileron” or “elevator” to have some “meeting rudder,” which is to move the unit in the opposite direction to the drifting.
- Every time a drift begins, use the “meeting rudder.” Try hard to make the unit hover above the same position.
- When you master this, you have learned to make your S.R.B hover.

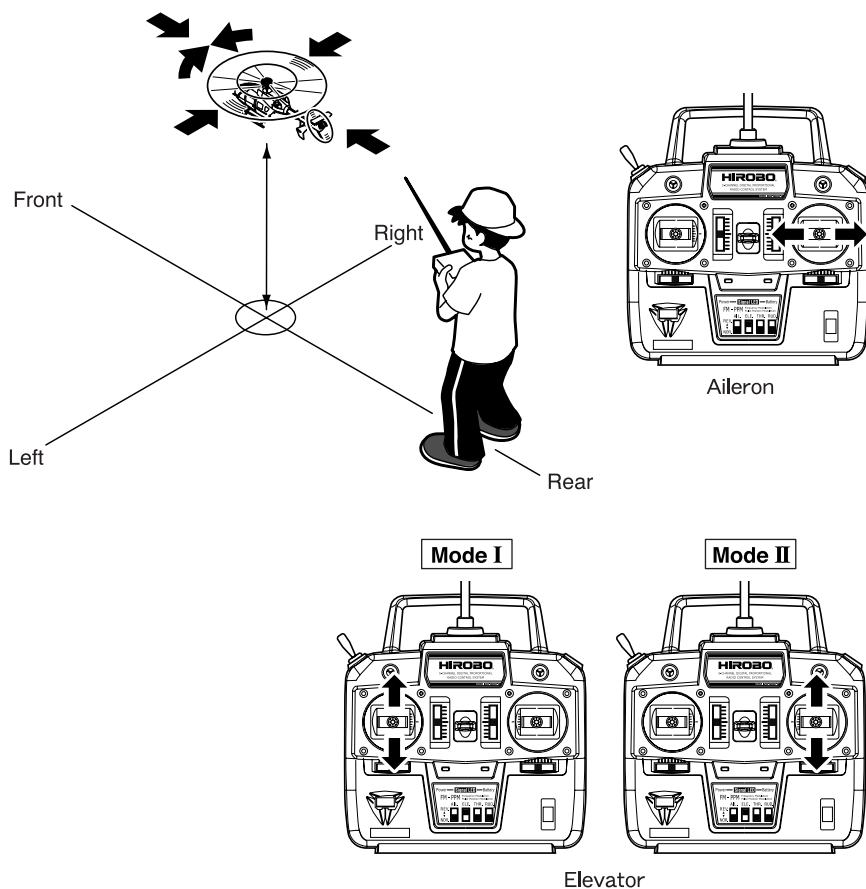

Point

- Every time you move a stick, try to give it the minimum movement you can in order to prevent the flying unit from tilting. A quick, large move of a stick cannot stabilize the unit.
- There will be a slight delay between when the rotor blade surface is angled and the unit begins to move. In order to quickly respond, pay close attention to the rotor blade surface during operation.

Point

- “Meeting rudder” operations can often take too much of your attention resulting in fluctuations in the flying unit's altitude. Be careful.
- Practice “meeting rudder” as if to roll a ball on a round tray.
- A wrong “meeting rudder” operation results in the flying unit drifting away in a large spiral.
- In the case that the unit has changed its nose direction, try some “rudder” while the unit is in the air to bring the nose direction back to the 12 o'clock direction.

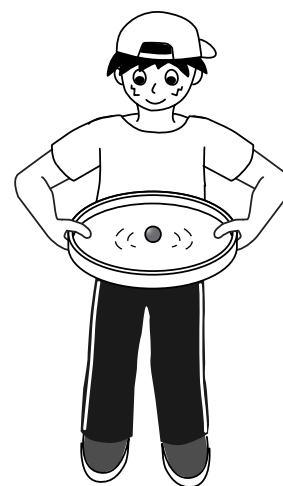

As if to roll a ball on a round tray

8. Practicing horizontal movement

Practice making your S.R.B move in the direction of your choice by doing “meeting rudder.” This is actually an extension of hovering.

● Practice

- First, make the flying unit hover at your waist level.
- Keep the unit's nose in the 12 o'clock direction and try moving the unit in directions of your choice.
- Practice so that you can make the unit hover at any position within the flight area.

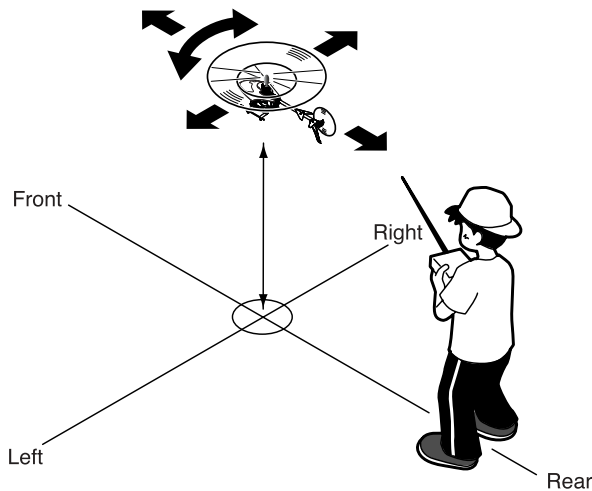

Point

- Every time you move a stick, try to give it the minimum movement you can, in order to prevent the flying unit from tilting too much. Without tilting the unit, you tilt the stick a little and wait for a while, and the flying unit slowly begins to move.
- Try to bring the flying unit's direction back to horizontal every time it tilts.

⚠ Caution

- “Meeting rudder” operations can often take too much of your attention resulting in fluctuations in the flying unit's altitude. Be careful.
- Practice “meeting rudder” as if to roll a ball on a round tray.
- A wrong “meeting rudder” operation results in the flying unit drifting away in a large spiral.
- In the case that the unit has changed its nose direction, try some “rudder” while the unit is in the air to bring the nose direction back to the 12 o'clock direction.

9. Practicing pirouettes

“Pirouette” refers to a helicopter's motion in which it spins around once while remaining in the same position. Unlike the X.R.B., using the rudder control of the S.R.B SG alone will not cause the flying unit to rotate horizontally. Please practice this maneuver in an open area until you become familiar with the controls. For those of you who cannot hover the unit from the front, do not panic when you cannot maintain a level flight, and also always bring the unit's nose back to facing the 12 o'clock direction.

● Practice

- First, make the flying unit hover around your waist level.
- Largely tilt the rudder stick to make the unit spin 360 degrees (1 spin).
- The key to this practice is to make the unit stop spinning with its nose in the 12 o'clock direction.
- This practice might make you nervous at first. Still, remember that you can always put the unit back into its correct orientation once you bring the unit back to its original hovering direction. Take it easy and try!
- When you get used to it, learn to make the pirouette both right and left.

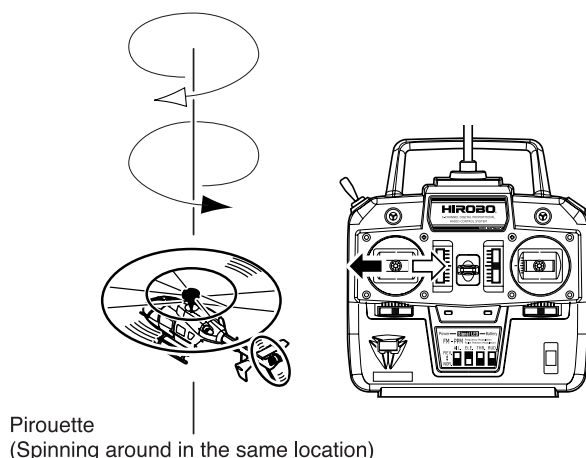

Point

- We suggest you practice a left pirouette first, since the stick operation (pulling the stick) is easier with the left pirouette.
- Using the rudder alone will cause the flying unit to slide on an angle. Try using the ailerons and elevators to make fine adjustments once you get used to the operation.

⚠ Caution

- Be careful not to let the unit's altitude fluctuate.
- Adjust the front/rear and left/right trims correctly beforehand.

12 / Unit Maintenance

1. General guidelines on disassembling the flying unit

Rotor head

Remove the rod end and the radius arm link attached to the swash lower plate ball, and loosen the main gear M2X6CS to remove the entire main mast.

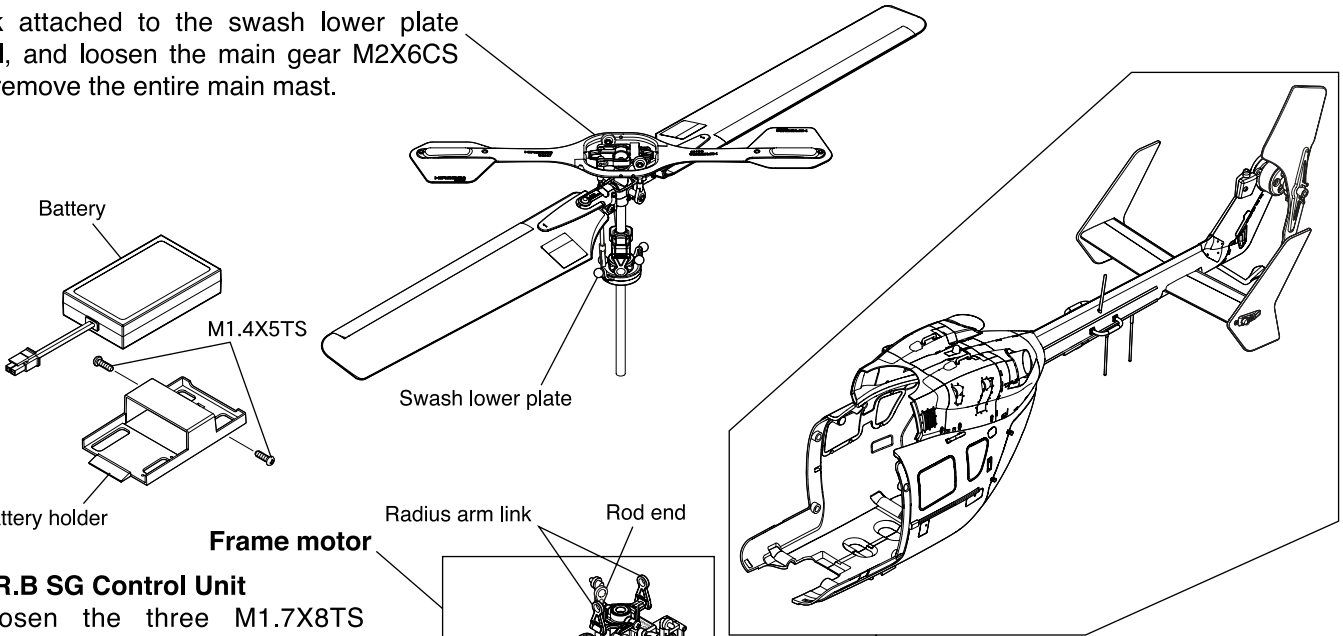

Frame motor

S.R.B SG Control Unit

Loosen the three M1.7X8TS screws, and slide upwards so the control unit can be removed from the main frame.

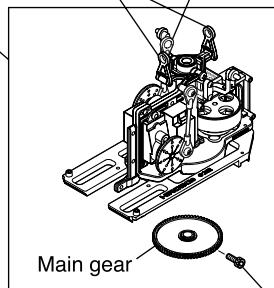
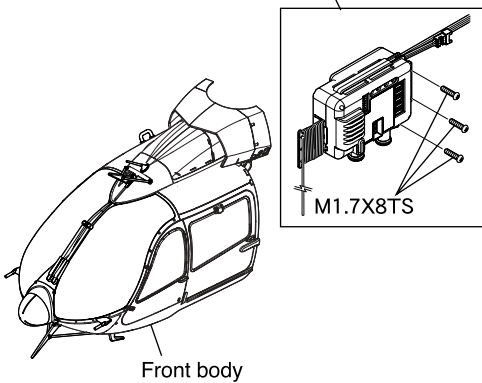

Rear body

Disconnect the tail motor and the back LED connector and loosen the four M1.4X5TS screws from the skid to remove the tail from the main frame.

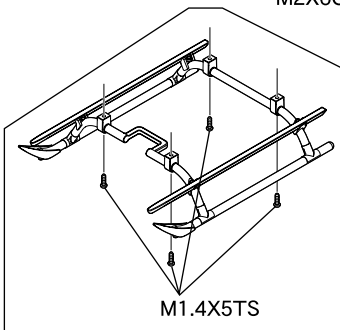

Skid

Loosen the four M1.4X5TS screws to remove the skid from the main frame.

Point

Is the main gear screw tight?

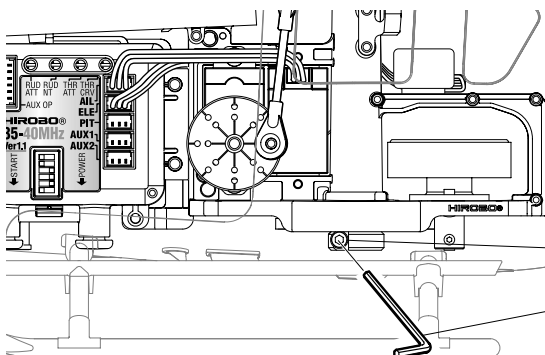

If the M2x6 cap screw in the lower mast lock attached to the lower black main gear comes loose, the main gear will slip on the main shaft and the motor will not be able to drive the main rotor head properly thus not allowing the heli to lift off when power is applied. Please check this screw from time to time as part of maintenance.

Cap screw M2X6

Allen wrench 1.5 mm (accessories)

Use the shorter end as the tightening lever. If the longer side is used as the tightening lever and the shorter end is put into the cap screw, you may break M2X6CS due to over-tightening.

2. Things to be checked after a fall

1. Is there anything broken?

First of all, check the unit for any damage.

If you find anything broken, disassemble the unit and replace the parts as necessary.

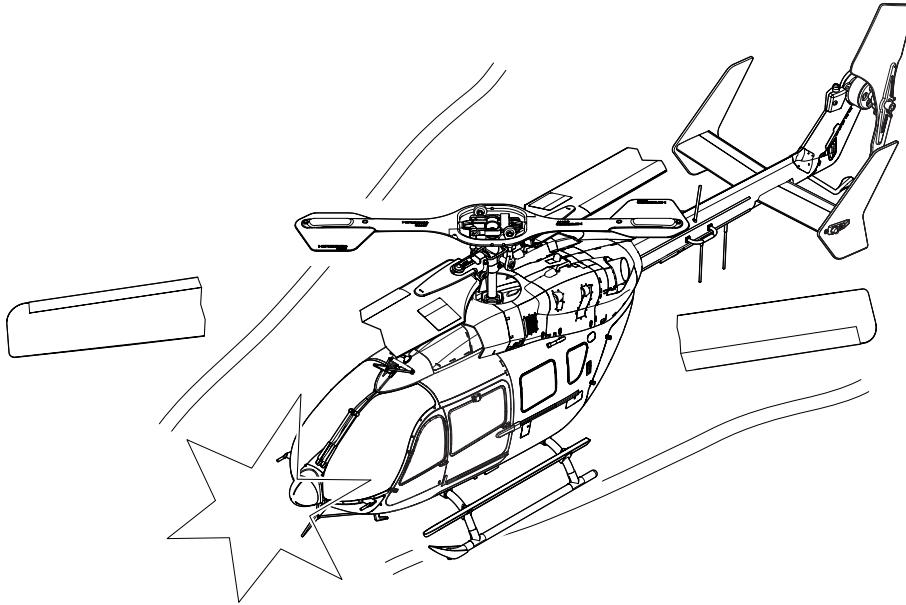

2. Is there a broken lead wire?

Check the servo, gyro, LED, motor and battery for any broken lead wire or connector.

Connection Diagram

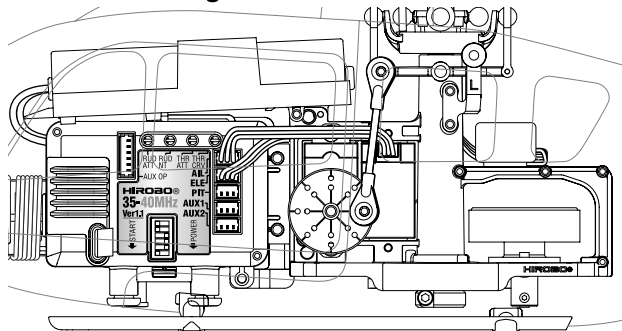

Left side

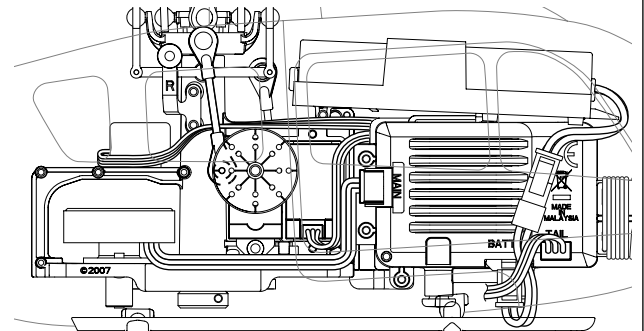

Right side

⚠ Caution

Though it rarely happens, if you find the connector of the battery broken and the terminal exposed, it might cause a short circuit. Wrap up the terminals with tape or tube to avoid contact between the plus and minus terminals, and dispose of them immediately.

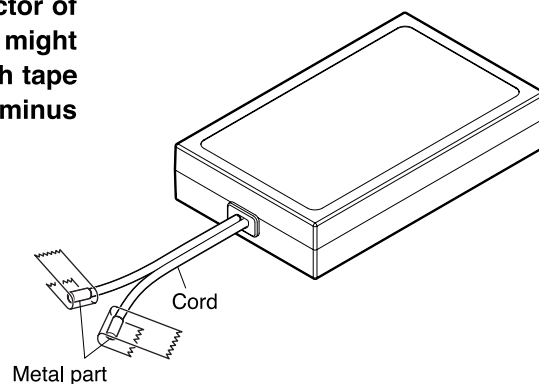

3. Is there any scratch or breakage to the main blade and the tail blade?

The main blade and the tail blade are made of foamed material and are designed to break if the unit falls. Replace them after every fall.

⚠ Caution

The blades may not have obvious damage depending of the height of the fall, but they are still likely to be cracked or bent. For your safety, replace them regardless of their appearance before the next flight.

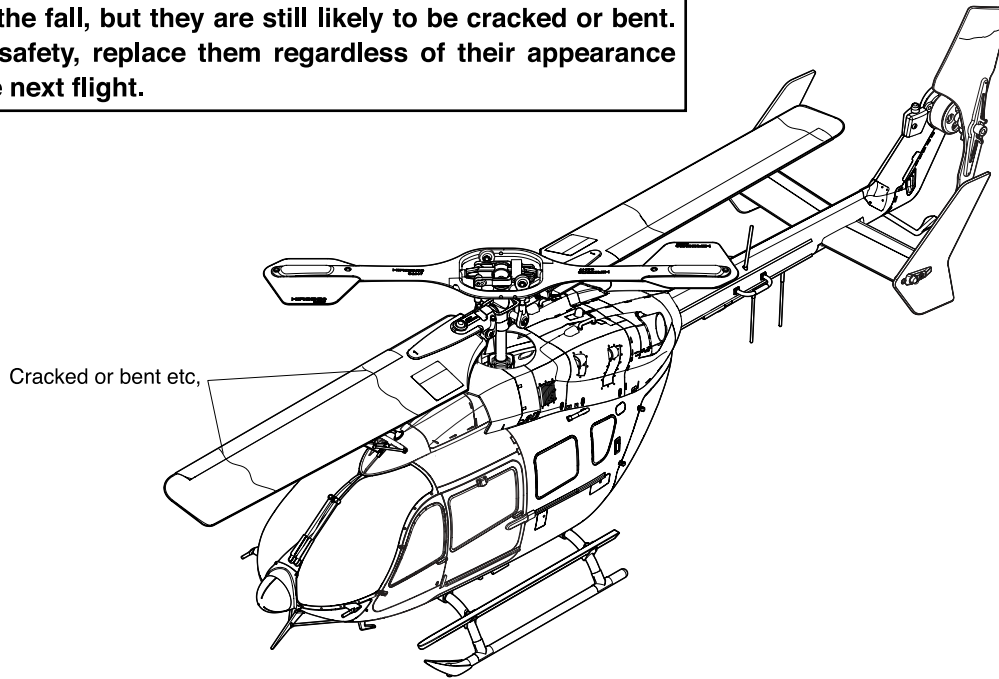

4. Is there any scratch or breakage to the stabilizer?

In the case of a fall or a crash, thoroughly check the stabilizer for any damage.

⇒ Breaks, chips, cracks, loosened bolts, etc.

Please note that the stabilizer blades and the stabilizer caps are both glued to the stabilizer arm. Please check that the impact did not make them fall off.

Exploded diagram
(Pre-assembled)

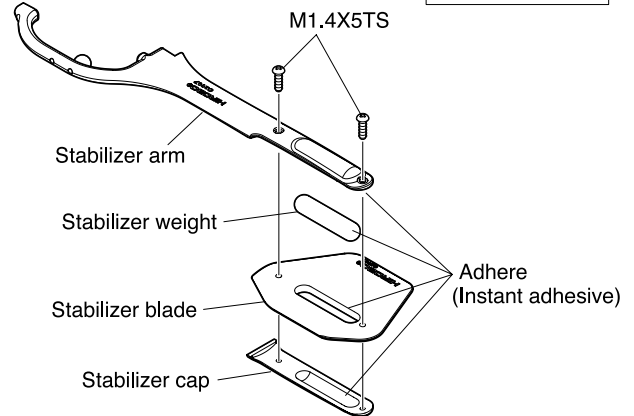

⚠ Caution

Do not use if you find something broken, the adhesive unstuck or a screw loose. It is extremely dangerous to keep flying like this because the vehicle's weight may be thrown about by the rotation.

5. Do the blades rotate smoothly?

Manually spin the main blade and the tail blade to see if they rotate easily.

If they stop in the middle of a turn, make funny noises or rotate too loosely as though there is little friction, the gear or the motor may be damaged.

Also, if the main mast wobbles when the blades are rotating, the main mast or the center hub may be damaged or deformed.

Disassemble and replace them as necessary.

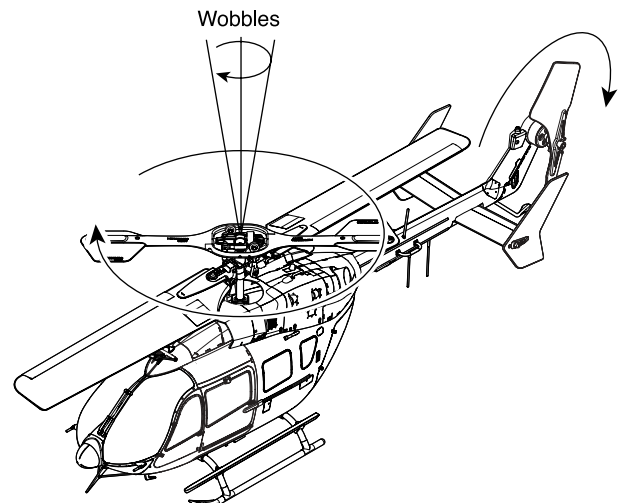

6. Do the levers move smoothly?

Remove all the linkage rods, and check that the swash plate and each lever moves smoothly. If any of them does not move smoothly or has too much backlash, disassemble it and check if it is damaged. If it is not, put it back together, and adjust it by changing the amount of tightening.

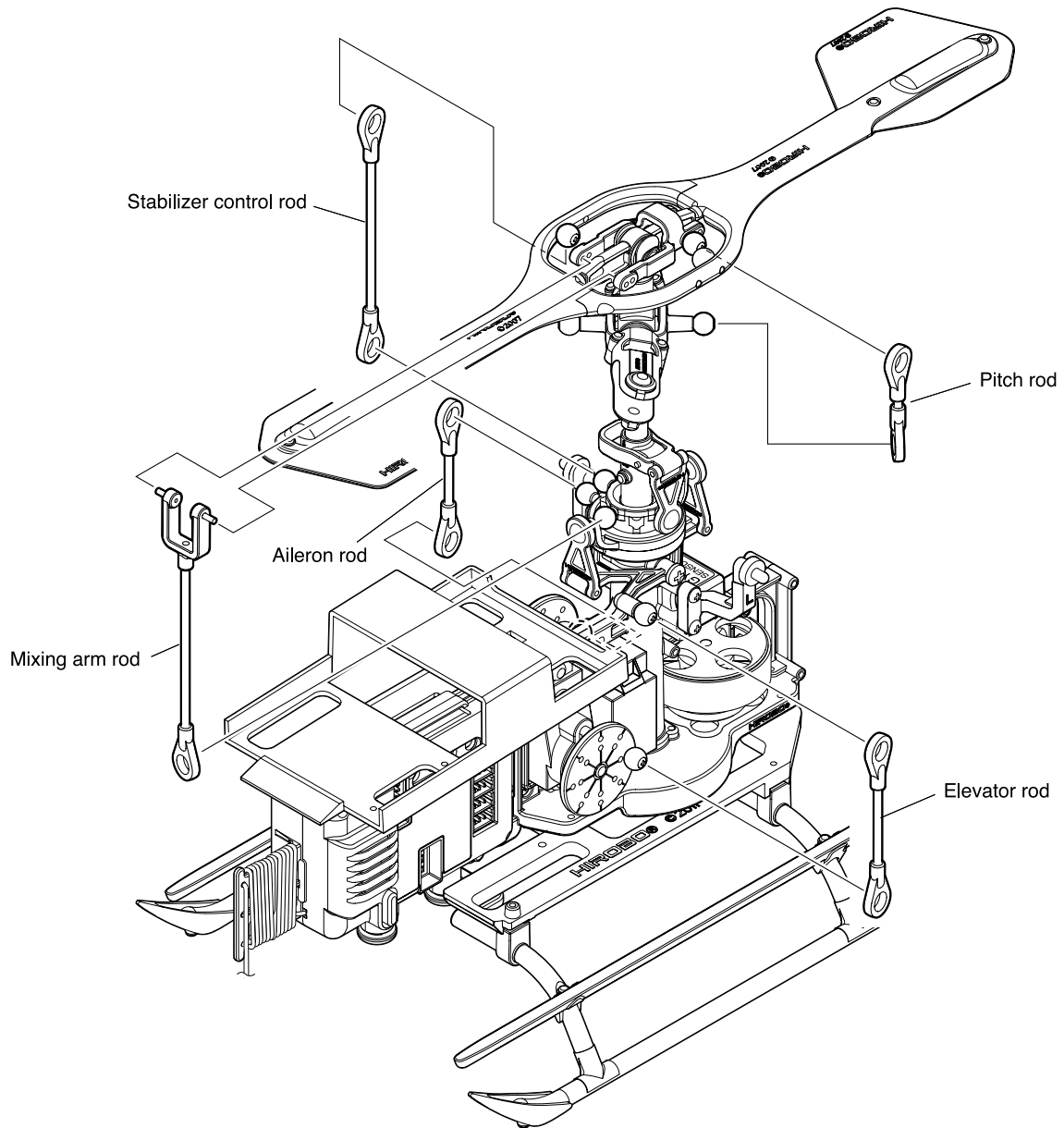

13 / Checkpoints for Flying Problems

- The part that has the most impact on helicopter flying is the main blade. There are often cases when flying performance has been improved just by replacing the main blade. Moreover there is a big difference in flying performance between a helicopter with a balance-adjusted main blade and a main blade that has not had the balance adjusted. In cases when the helicopter is not flying well, we recommend the first line of action is to replace the main blade with one that has had its balance adjusted.

- If the flying unit does not move at all
 - ① Check that the power of the transmitter and flying unit are on. See page 53.
 - ② Check that the battery levels of the batteries in the transmitter and in the flying unit are sufficient. See pages 7 to 10. and see also the instruction manual for the transmitter.
 - ③ Check that the radio frequency of the transmitter's crystal is the same as that of the flying unit. See pages 9 to 11.
 - ④ Make sure that the crystal has been inserted properly. See page 11.
 - ⑤ Check that the transmitter manufacturer selection switch is set correctly. See page 48.
 - ⑥ This product has been designed so that when the safety lock has not been cleared, the motor will not rotate. See page 53.
 - ⑦ Is the throttle trim raised to the up position? See page 59.
 - ⑧ Check whether the transmitter's modulation method is either AM or PCM. See also the instruction manual for the transmitter.

- If there is faulty operation or the flying unit is moving jerkily
 - ① Check that the battery levels of the batteries in the transmitter and in the flying unit are sufficient. See pages 7 to 10. and see also the instruction manual for the transmitter.
 - ② Is the antenna of the transmitter extended? See page 57.
 - ③ There is a possibility that radio waves of the same frequency are being used nearby. See page 4.
 - ④ The flying unit suddenly lands during a flight See pages 5, 58, 82.
 - ⑤ The LED lamp on the S.R.B. control unit flashes to indicate an error, or there is motor noise See page 82.
 - ⑥ When the throttle is raised, the motor turns but the unit does not take off. See page 66.
 - ⑦ Is the antenna of the control unit dropped down from the hole? See page 11.

- When the flying unit does not stop rotating
 - ① The rudder has not been adjusted properly. See page 61.
 - ② It is possible the tail motor is damaged or worn. Rotate the tail rotor by hand to make sure it rotates smoothly and does not generate strange noises. If not, replace the motor.

- When flying unit moves forward/reverse and left/right, and cannot hover
 - ① Is the flying unit being caught in a wind caused by an air conditioner or the like? ...Continue practicing when the air is still until you are familiar with the controls. Fly the unit with the windows closed and the air conditioner off.
 - ② Is the trim adjustment done correctly? See page 60 and 61.
 - ③ Is the ground effect not affecting the flying unit? See page 62.
 - ④ Do you understand the drift effect with single rotor helicopters? See page 59.

- When the unit vibrates strongly
 - ① Is the tape on the edge of the main blade coming off? See page 57.
 - ② Is main blade moving smoothly in forwards/reverse? See page 51.
 - ③ Is the tracking adjustment done correctly? See page 55.
 - ④ Are the main blades' centers of gravity balanced correctly? See page 51.
 - ⑤ Is the tail blade balanced correctly? See page 52.

14 / Parts list

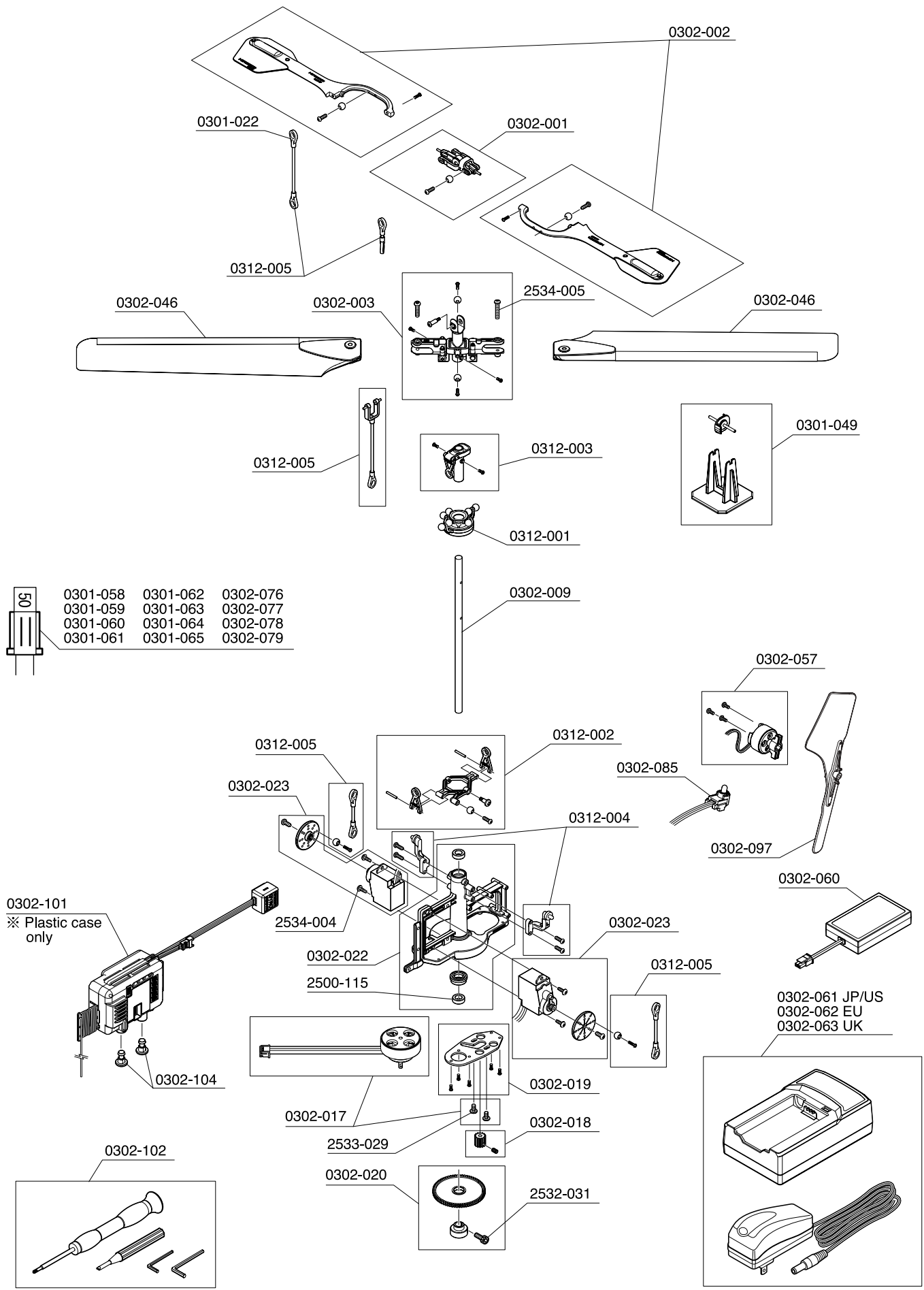

*The prices in parentheses are the prices excluding consumption tax.

Code No.	Part	Quantity	Price (Yen)	Remarks
0301-022	ø4 rod end	10	525 (500)	
0301-023	EX ø4 ball	10	1,050 (1,000)	
0301-049	XRB blade balancer	1	525 (500)	
0301-058	XRB-SR crystal 40.665MHz/50	1	1,680 (1,600)	
0301-059	XRB-SR crystal 40.695MHz/53	1	1,680 (1,600)	
0301-060	XRB-SR crystal 40.715MHz/54	1	1,680 (1,600)	
0301-061	XRB-SR crystal 40.735MHz/56	1	1,680 (1,600)	
0301-062	XRB-SR crystal 35.040MHz/64	1	1,680 (1,600)	
0301-063	XRB-SR crystal 35.080MHz/68	1	1,680 (1,600)	
0301-064	XRB-SR crystal 35.120MHz/72	1	1,680 (1,600)	
0301-065	XRB-SR crystal 35.140MHz/74	1	1,680 (1,600)	
0302-001	S.R.B seesaw ASSY	1 set	1,575 (1,500)	Assembled
0302-002	S.R.B stabilizer ASSY	1 set	1,680 (1,600)	Assembled
0302-003	S.R.B center hub blade holder	1 set	1,890 (1,800)	Assembled
0302-009	S.R.B main mast	1	735 (700)	
0302-017	S.R.B bursh less main moter	1	6,300 (6,000)	With lead line and connector
0302-018	S.R.B pinion gear 14T	1	525 (500)	
0302-019	S.R.B moter plate set	1	525 (500)	
0302-020	S.R.B main gear 74T	1	1,050 (1,000)	Gear press-fitted.
0302-022	S.R.B main frame	1	1,050 (1,000)	
0302-023	S.R.B servo	1	3,675 (3,500)	With servo horn
0302-046	S.R.B SG main blade set	8	2,625 (2,500)	
0302-057	S.R.B SG tail moter	1	5,775 (5,500)	
0302-060	Lipo battery 11.1V 480mAh	1	8,400 (8,000)	
0302-061	11.1V 3Cell Lipo battery charger JP/US	1	10,500 (10,000)	
0302-062	11.1V 3Cell Lipo battery charger EU	1	10,500 (10,000)	
0302-063	11.1V 3Cell Lipo battery charger UK	1	10,500 (10,000)	
0302-076	S.R.B crystal 72.510MHz/36	1	1,680 (1,600)	
0302-077	S.R.B crystal 72.550MHz/38	1	1,680 (1,600)	
0302-078	S.R.B crystal 72.590MHz/40	1	1,680 (1,600)	
0302-079	S.R.B crystal 72.630MHz/42	1	1,680 (1,600)	
0302-085	S.R.B back LED	1	840 (800)	
0302-097	S.R.B tail blade set (W)	4	840 (800)	
0302-100	S.R.B screw set	1 set	1,260 (1,200)	
0302-101	S.R.B SG repair unit case ver.1.1	1 set	1,575 (1,500)	
0302-102	S.R.B tool set	1 set	525 (500)	
0302-104	S.R.B SG switch	2	525 (500)	
0312-001	S.R.B scale swash plate ASSY	1	1,680 (1,600)	
0312-002	S.R.B scale swash base plate	1	840 (800)	
0312-003	S.R.B scale washout ASSY	1	840 (800)	
0312-004	S.R.B scale body stay set	1	630 (600)	For S.R.B EC145 R/L / For S.R.B SG R/L
0312-005	S.R.B scale linkage set	1	1,470 (1,400)	
2500-115	Brg. ø4Xø7X2.5ZZ	2	1,260 (1,200)	Can be used for S.R.B Quark.
2532-031	Cap screw M2X6	10	840 (800)	
2533-029	Philips-head screw M2X4 truss	10	420 (400)	
2534-004	Tapping screw M2X5 black	10	105 (100)	
2534-005	Tapping screw M2X10 No.2 type	10	105 (100)	

* For maximum safety, the main blades and tail blades are made of foamed polystyrene. They are breakable parts. For ordering, please carefully check the code numbers in the above list.

0312-921

0312-008

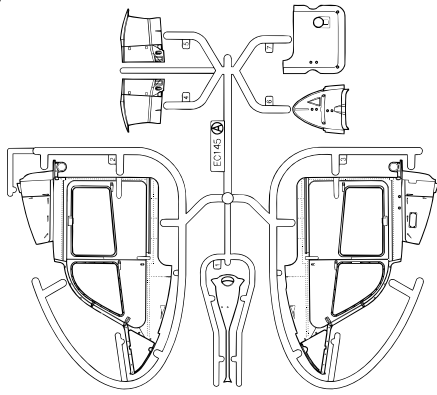

0312-009

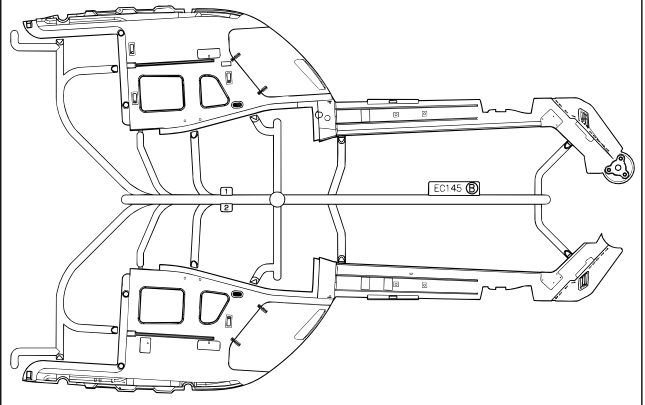

0312-010

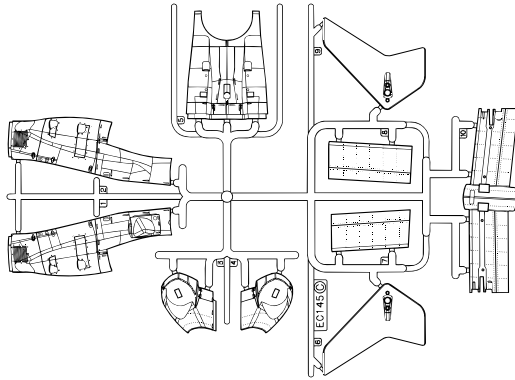

0312-011

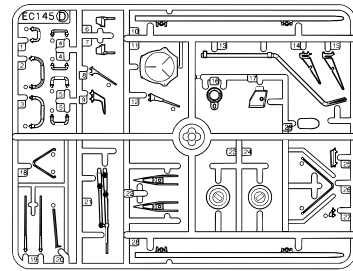

0312-012

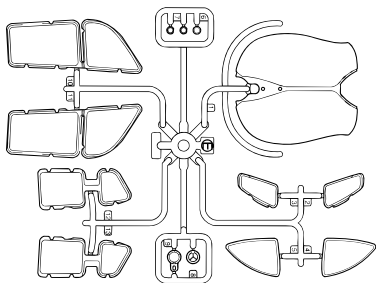

0312-013

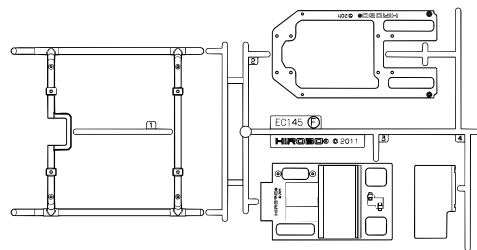

0312-014 (Sold in set only)

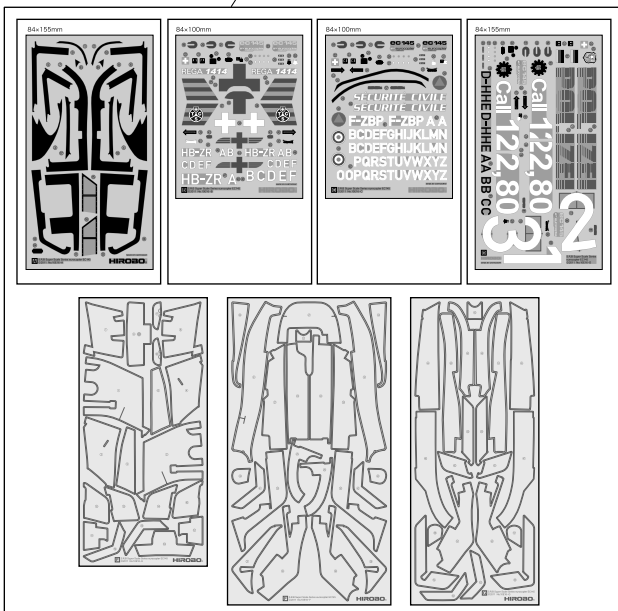

0312-006

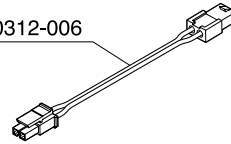

0312-017

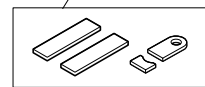

0312-004

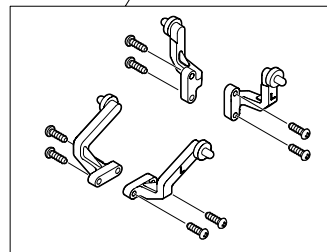

*The prices in parentheses are the prices excluding consumption tax.

Code No.	Part	Quantity	Price (Yen)	Remarks
0312-004	S.R.B scale body stay set	1	630 (600)	For S.R.B EC145 R/L / For S.R.B SG R/L
0312-006	S.R.B battery extension cord L40	1	2,100 (2,000)	
0312-008	S.R.B EC145 front body set	1 set	2,100 (2,000)	With screws
0312-009	S.R.B EC145 rear body set	1 set	2,100 (2,000)	With screws
0312-010	S.R.B EC145 fin, top cover set	1 set	2,100 (2,000)	With screws
0312-011	S.R.B EC145 antenna set	1 set	2,100 (2,000)	With screws
0312-012	S.R.B EC145 clear parts set	1 set	2,100 (2,000)	With screws
0312-013	S.R.B EC145 skid set	1 set	2,100 (2,000)	With screws
0312-014	S.R.B EC145 decal	1	3,675 (3,500)	Not sold individually.
0312-015	S.R.B scale LED light unit	1 set	9,450 (9,000)	
0312-016	S.R.B scale LED set	1 set	3,675 (3,500)	
0312-017	S.R.B EC145 double-sided adhesive tape set	1 set	525 (500)	
0312-921	S.R.B EC145 body set	1 set	15,750 (15,000)	With screws

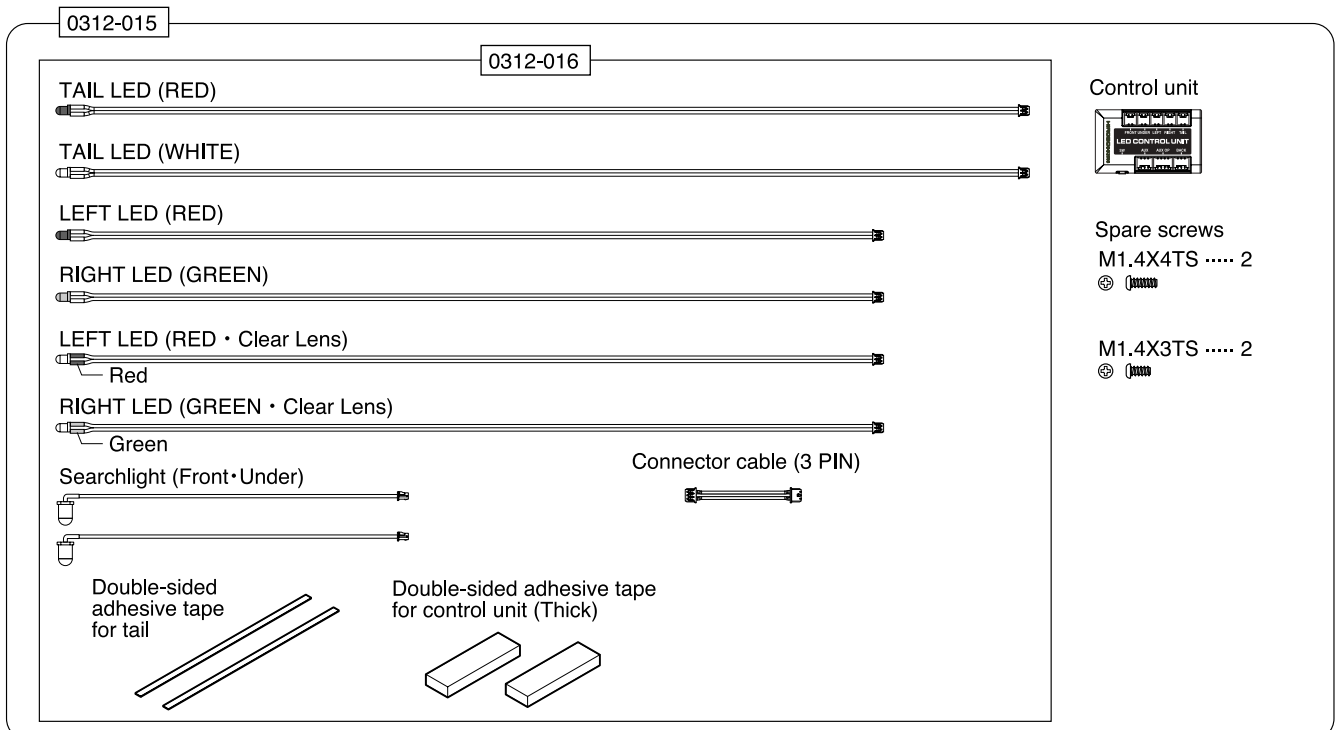

15 / Expert level: Using the optional features

1. Adjusting the throttle curve

- * This setting is adjusted when the flying unit is shipped from the factory.
- * Enabled only in the normal mode (idle up OFF) of reception mode 1/2/5.

This section explains how to adjust the transmitter's throttle stick to the central (neutral) position when hovering by adjusting the control unit's THR CRV (throttle curve) adjustment volume.

THR CRV Throttle curve adjustment volume

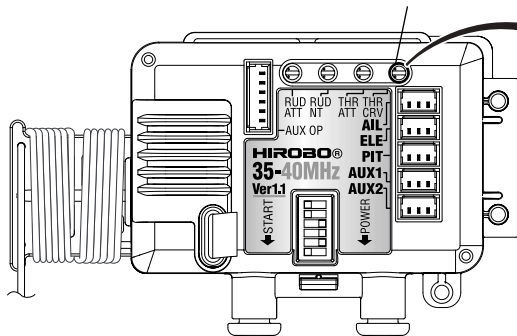

Point

The THR CRV volume adjuster is not enabled while it is in reception mode 3 or 4. Make adjustments on the transmitter side.

Point

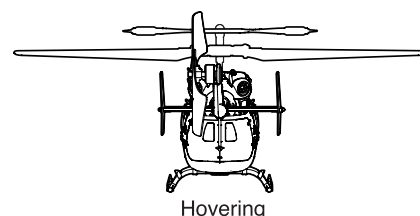

When the transmitter's throttle stick position when hovering is below the neutral position:
Turn the THR CRV (throttle curve) adjustment volume to the left.

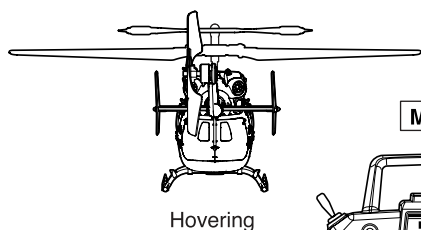

Hovering

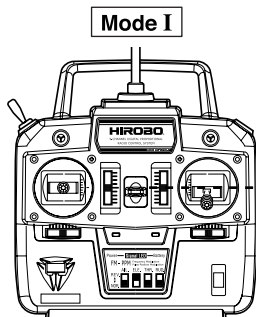

Mode I

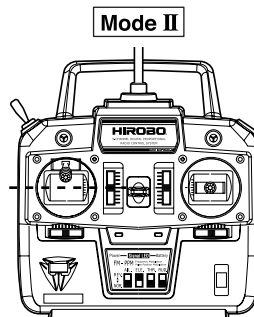

Mode II

Throttle stick is below the neutral position.

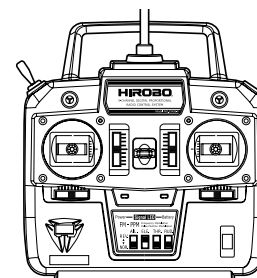
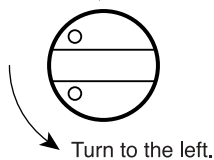

The throttle stick is near the neutral position.

The transmitter's throttle stick should be in the central (neutral) position when the unit is hovering.

When the transmitter's throttle stick position when hovering is above the neutral position:
Turn the THR CRV (throttle curve) adjustment volume to the right.

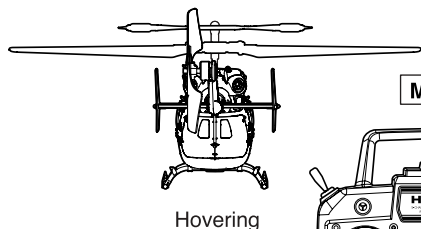

Hovering

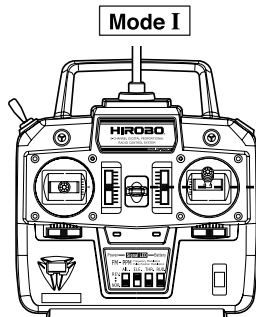

Mode I

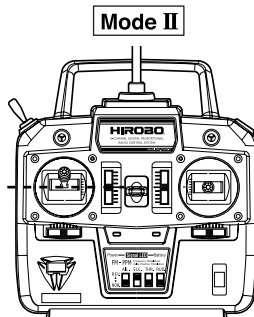

Mode II

Throttle stick is above the neutral position.

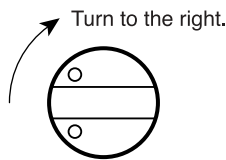

【What is the throttle curve?】

As shown in the following diagram, the throttle curve means the adjustment of the motor output in relation to the stick position.

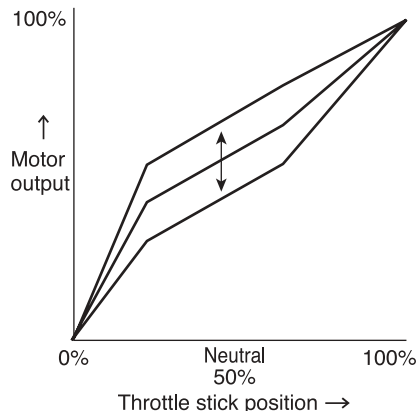

2. Adjusting rudder rotation speed

* This setting is adjusted when the flying unit is shipped from the factory.

It is possible to use the control unit's RUD ATT (rudder rate adjustment dial) to speed up or slow down the rudder rotation speed.

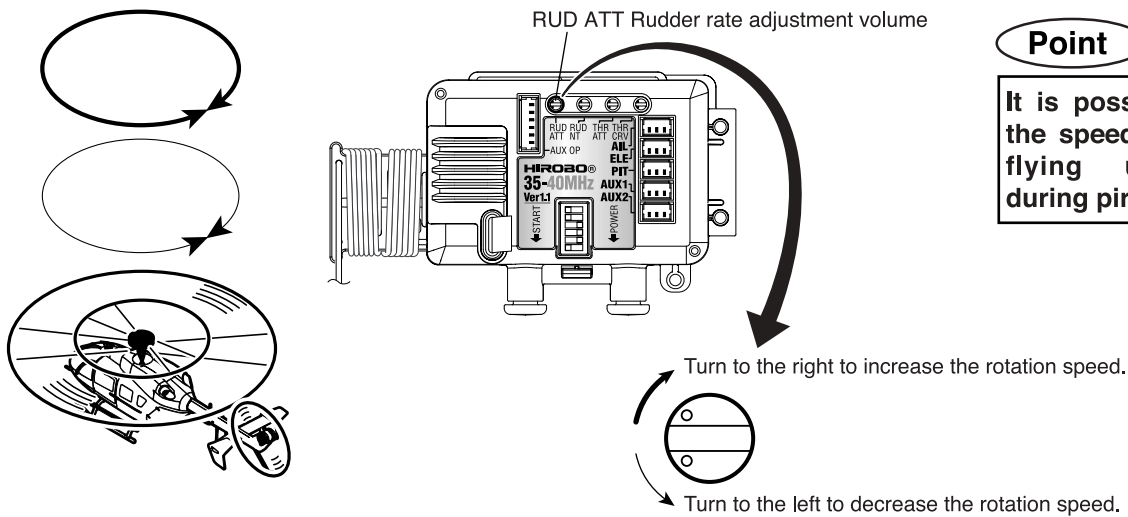

Point

It is possible to adjust the speed at which the flying unit rotates during pirouettes.

3. Adjusting the sub-trim in neutral

With the transmitter sticks and trims in the neutral position, each servo can be adjusted, as explained in the following procedures, by adjusting the sub-trims.

[Procedures]

The setting can be adjusted while the power of the transmitter is turned OFF.

① Hold down the start switch and press the power switch.

If the red LED starts flashing one flash at a time, it indicates that it is in the sub-trim adjustment mode.

② Adjust the three servo horns horizontally with the volume adjuster on the control unit.

③ Hold down the start switch and press the power switch for three seconds to turn off the power. This operation stores the sub trim settings.

④ Turn the volume adjuster on the control unit to the original position.

⑤ Turn ON the power again, and check that the servo horns are horizontal when the transmitter trims are in the neutral position.

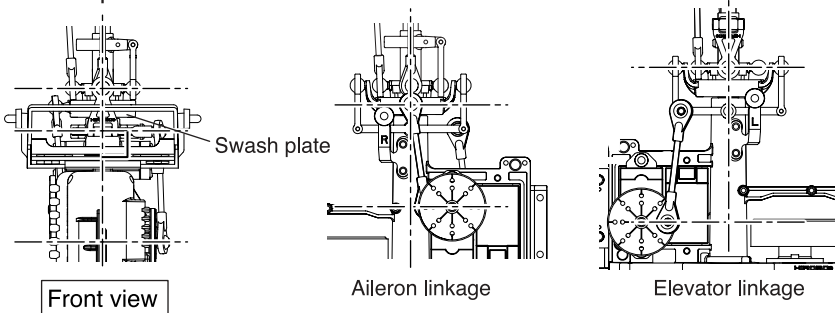

Point

If you press the start switch in step ②, the LED color changes from red to orange, and it sends off signals when the transmitter is in the neutral position. Use this function when attaching the servo horns to the servos.

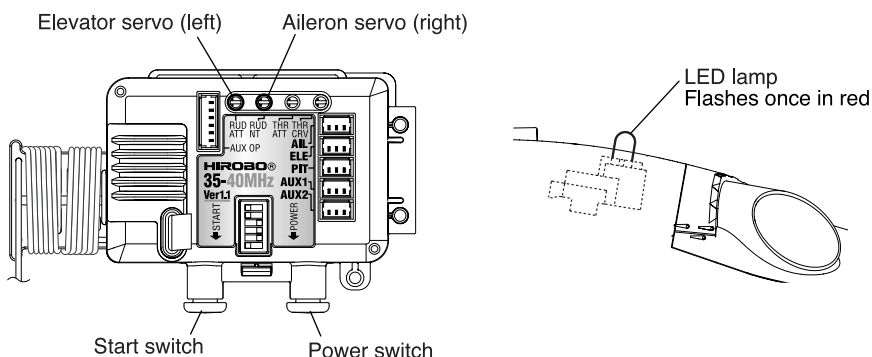

Point

If the swash plate is not horizontal after adjusting the sub-trims, try it again by changing the length of the adjust rod.

4. Adjusting the gyro sensitivity

* The gyro is adjusted to the right sensitivity level when the flying unit is shipped from the factory.

By switching to the gyro sensitivity adjustment mode, it is possible to adjust the sensitivity of the rudder gyro.

When the sensitivity of the gyro is high, the tail will vibrate slightly back and forth, a phenomenon known as "hunting".

On the other hand, when the sensitivity is low, the tail hovering will be dulled.

⚠ Caution

While in the receiver mode 3 and 4 (please see page 80), the gyro sensitivity cannot be adjusted from the control unit. Please adjust it by using the transmitter.

When the gyro sensitivity is high,

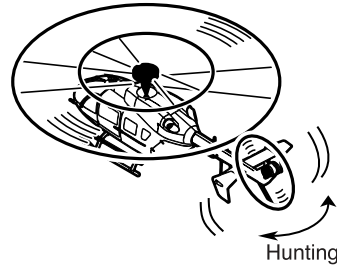

the tail will vibrate

When the gyro sensitivity is low,



the tail hovering will be dulled

[Procedures]

- ① Turn the transmitter power on.
- ② Place the unit on a flat surface, and press the power switch. Do not move the unit until the flashing green LED turns to a constant green.
- ③ Press the start switch (with the transmitter's throttle stick at the slowest position).
- ④ After adjusting the safety device, again hold the start switch down while keeping the throttle stick of the transmitter at the slowest position.
- ⑤ When the tone of the motor rises, and the LED starts to flash alternately in green and orange, it indicates that the unit is in the gyro sensitivity adjustment mode.
- ⑥ Once in the gyro sensitivity adjustment mode, the RUD ATT adjustment volume becomes the gyro sensitivity adjustment volume. Fly the unit, and adjust the sensitivity until it is just short of causing the tail to start "hunting".
- ⑦ After adjusting the volume, it is necessary to save the gyro sensitivity settings. Hold down the start switch, and press the power switch for three seconds to turn off the power.
- ⑧ Turn the volume adjuster on the control unit to the original position.

Point

After completing the gyro sensitivity adjustment mode, the RUD ATT volume position will be reflected on the rudder rotation speed. Please readjust this volume to the desired setting.

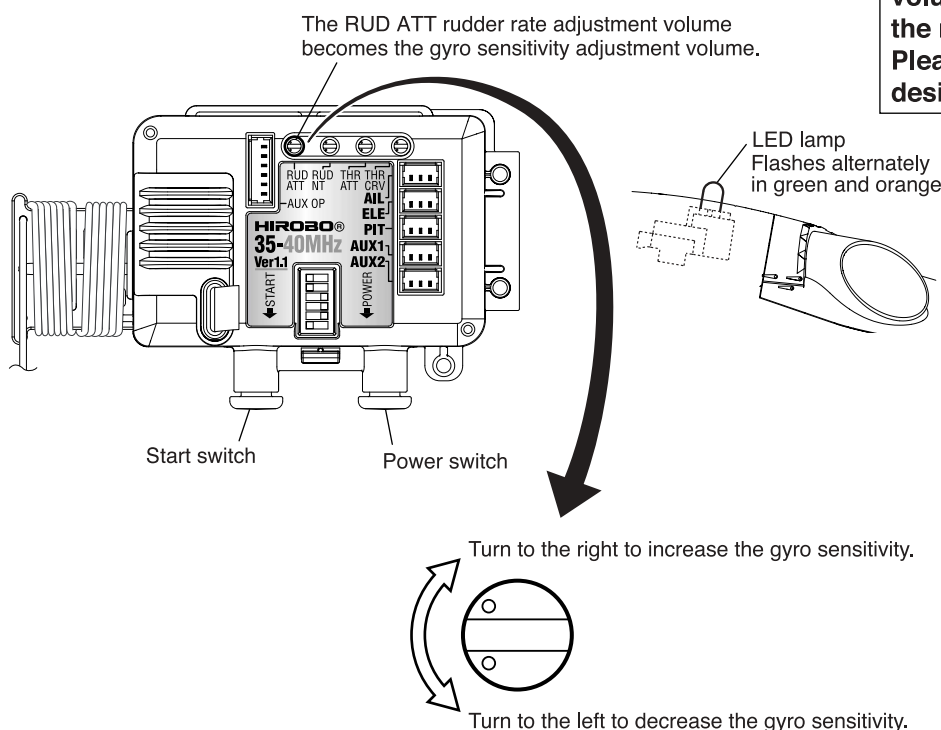

5. Switching the gyro sensitivity adjustment channel

While in receiver mode 3 and 4, it is possible to adjust the sensitivity of the gyro through the transmitter.

In the default setting, channel 5 is assigned for this function.

It is possible to change it to channel 7 from the control unit while it is in the setup mode.

Point

Please see page 80 for receiver modes.

■ Adjusting the gyro sensitivity by rudder angle adjustment

Sensitivity of the gyro can be adjusted by adjusting the rudder angle of channel 5 (or 7).

If you switch between normal and reverse, you can also switch between tail hold and normal.

Transmitter rudder angle and gyro sensitivity

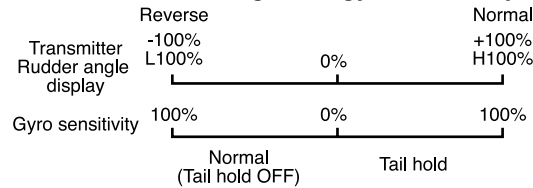

■ Using the gyro sensitivity adjustment function

If your transmitter has a setting to allow making adjustments to the gyro sensitivity according to the flight conditions such as idle up, assign a channel for the gyro sensitivity adjustment on the control unit to make this function available.

Please check which channel is used for gyro sensitivity adjustment in your transmitter.

Example of gyro sensitivity display on transmitter

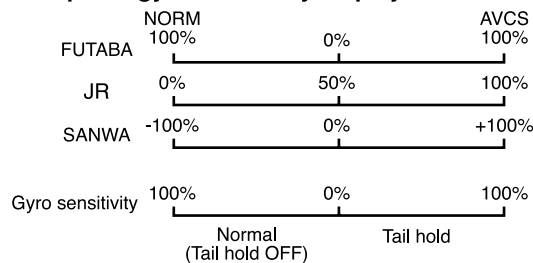

[Procedures]

Turn off the power of the transmitter and flying unit.

- ① Turn the transmitter power on.
- ② Hold down the start switch and press the power switch.
- ③ Press the power switch three more times.
 - If the red LED starts flashing four flashes at a time, it indicates that it is in the gyro sensitivity adjustment channel switching mode.
- ④ Press the start switch. The LED turns from red to orange.
 - Flashing red LED: 5 channel
 - Flashing orange LED: 7 channel
- ⑤ Hold down the start switch and press the power switch for three seconds to turn off the power.

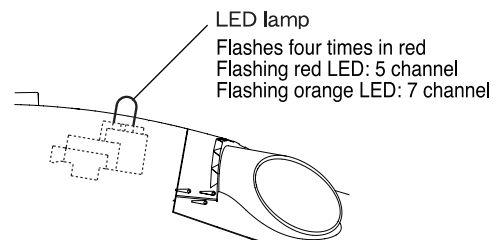
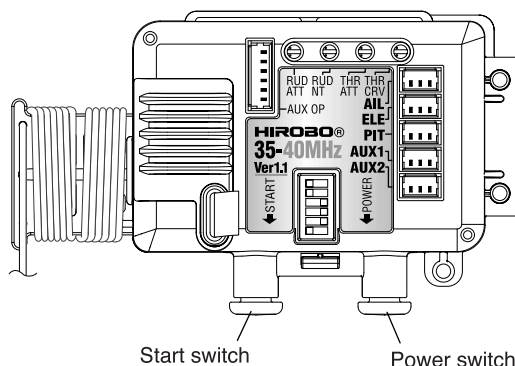

6. Resetting the data

* Do not perform this operation unless necessary

Resetting the data allows you to reset the sub trim and gyro sensitivity settings.

It also resets the settings for the rudder angle of the aileron and elevator, tail motor rotation direction and the gyro sensitivity adjustment channel, and they will return to the default values.

[Procedures]

Turn off the power of the transmitter and flying unit.

- ① Turn the transmitter power on.
 - ② Hold down the start switch and press the power switch.
 - ③ Press the power switch six more times. If the LED starts to flash alternately in red and orange, it indicates that it is in the data reset mode.
 - ④ Hold down the start switch and press the power switch for three seconds to turn off the power.
- This operation will reset the data.

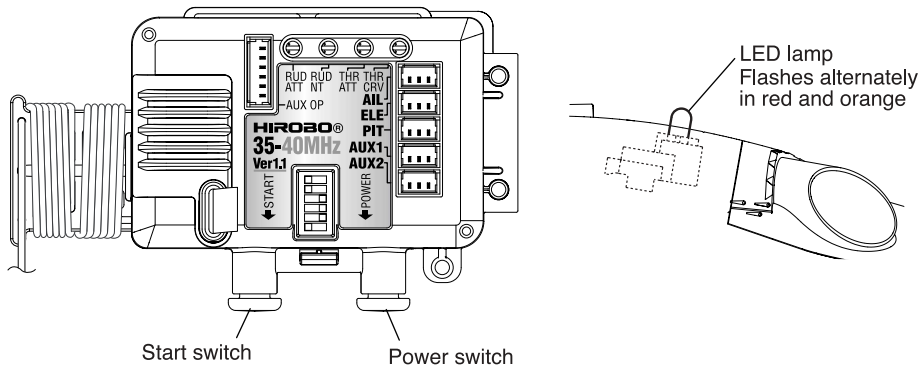

7. Changing direction of tail motor rotation

When shipped, the S.R.B EC145's tail motor is set to rotate in the opposite direction (clockwise) from which it is attached.

* Resetting data will require you to change the direction of the tail motor's rotation.

[Procedures]

- ① Press the power switch while pressing down the start switch.
- ② Press the power switch five more times.
 - Normal (counter-clockwise): LED (red) flashes six times.
 - Opposite (clockwise): LED (orange) flashes six times.
- ③ If you press the start switch once, it changes the color of the LED's flashing light and the direction of the rotation between normal and opposite.
- ④ Press down the power switch and the start switch simultaneously for three seconds to turn it off.

These commands will change the direction of the tail motor's rotation.

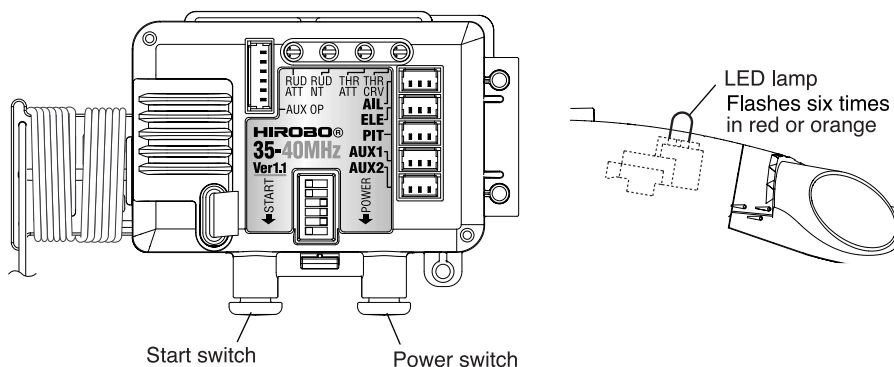

Point

The S.R.B Quark SG's control unit is set to normal (counter-clockwise).

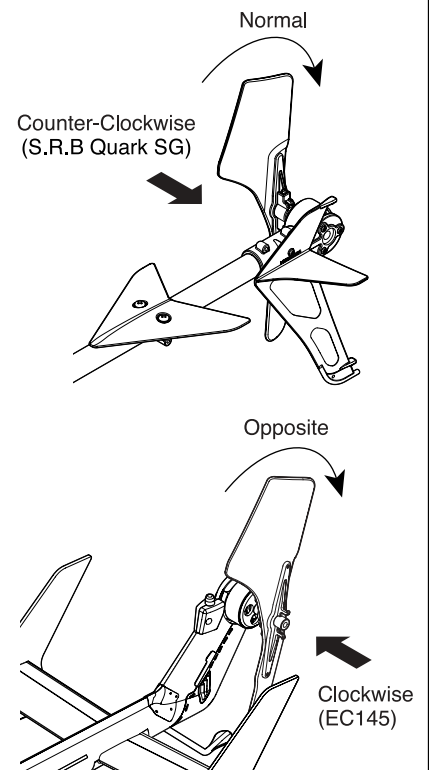

8. Switching the receiver mode

- Receiver Mode 5 is the initial setting.
- Experts who want to customize settings can set it to Receiver Mode 4 to adjust the transmitter's throttle curve and gyro sensitivity.
- **Receiver Modes 1 through 3 cannot be used with this product.**

Referring to the table below, adjust the settings.



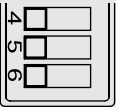
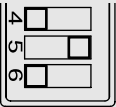
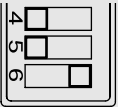
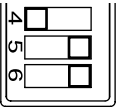
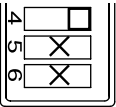



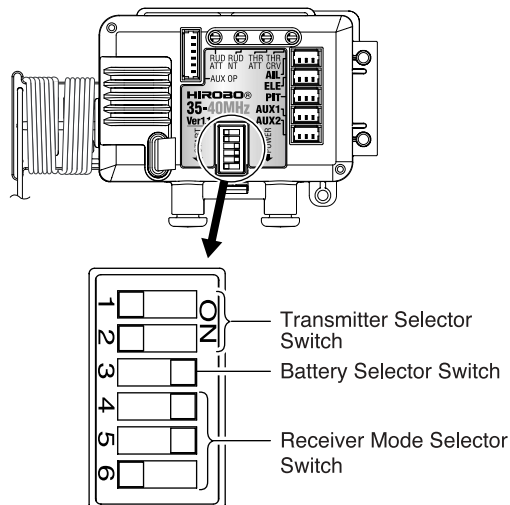





















S.R.B Quark SG Control Unit Switching the receiver mode

Receiver Mode	Receiver Mode 1	Receiver Mode 2	Receiver Mode 3	Receiver Mode 4	Receiver Mode 5
Output	4CH transmitter Transmitters with 5 or more channels can also be used, but the idle up function is not available.	5CH transmitter If you use transmitters with 5 or more channels, you can also use the pitch curve, throttle curve, and swash mixing function incorporated in the control unit.	Transmitter with 6CH or more Enables setting the pitch curve and throttle curve through the transmitter.	Transmitter with 6CH or more Enables setting the throttle curve through the transmitter.	Fixed pitch 2-servo mode * Cannot be used on the S.R.B Quark SG.
Aileron servo	Aileron channel			Aileron channel	
Elevator servo	Elevator channel			Elevator channel	
Main motor	Throttle channel			Throttle channel	
Tail motor	Rudder channel			Rudder channel	
AUX1	5CH	6CH	7CH (※5CH)	7CH (※5CH)	5CH
AUX2	7CH	7CH	8CH	8CH	7CH
Idle up	×	5CH	Transmitter side	Transmitter side	×
Gyro Sensitivity Adjustment	Unit side	Unit side	5CH (※7CH)	5CH (※7CH)	Unit side
Swash mixing	Unit side (Swash mode)	Unit side (Swash mode)	Unit side (Swash mode)	Transmitter side (Use normal mode)	Normal mode
Throttle curve	Unit side	Unit side	Transmitter side	Transmitter side	Unit side
On/Off Switches	 OFF OFF OFF OFF	 OFF OFF OFF OFF	 OFF OFF OFF ON	 OFF ON ON ON	 ON X X X
For 5 and 6, switching ON/OFF does not make any difference.					

* Switch it by using the control unit's setup mode according to the transmitter used. In doing so, the output channel of AUX1 is switched over.















S.R.B EC145 Control Unit Function List

	Item	Operation	Red LED	Green LED	Orange LED	Motor sound	Throttle	Servo	Notes	Reference Page	
Normal Operation	Power On	Power switch ON	 Flashes	—	 ↓  Flashing to On		Inoperable	Stops	Initialization is carried out by turning ON the power switch. When initialization is complete, the LED changes from alternately flashing red and orange to only orange (non-flashing). (Note: If the throttle stick is NOT in the lowest position, the LED is green. It stops flashing after the initialization and stays lit.)	P.53	
	Before disengaging the safety device		—	—	 On	—	Inoperable	Operable		P.53	
	Throttle at slowest setting		—	—	 On	—	Inoperable	Operable		P.54	
	Safety device disengaged	Start switch ON	—	 On	—	—	Operable	Operable		P.54	
	Rotation speed display 3 cell	Approx. 2150rpm to Approx. 2400rpm		—	—	 On	—	Operable	Operable	Orange LED is lit to indicate that the rotation speed of the main blade within the range.	P.56
	Idle up	Idle up switch ON	—	 Flashes (On)	—	—	Operable	Operable	Green LED flashes at receiver mode 2. Green LED is lit at receiver mode 3 or 4.		
	Power Off	Hold power switch for one second	—	—	—		Stops	Stops		P.53	
	Automatically turns of the power if no operations made for five minutes		—	—	—		Stops	Stops		P.53	
Set-up mode	Set-up mode	Hold down the start switch and press the power switch to turn on the power	—	—	—		Inoperable	Operable	Save settings for each item.		
	1 Sub trim adjustment		 Flashes once	—	—	—	Inoperable	Operable by the volume	Use the following corresponding volumes for each servo trim adjustment. RUD ATT→elevator servo RUD NT→aileron servo THR ATT→pitch servo After the adjustment, turn the volume adjuster to the original position.	P.76	
	Check neutral	Press the start switch while in the sub-trim adjustment mode to have a 1500µs signal.	—	—	 Flashes once	—	Inoperable	Inoperable		P.76	
	2 Sub-trim adjustment on high side	Press the power switch once.	 Flashes Two times	—	—	—	Inoperable	Operable by the volume			
	3 Sub-trim adjustment on low side	Press the power switch twice.	 Flashes three times	—	—	—	Inoperable				
	4 Switching the gyro sensitivity adjustment channel	Press the power switch three times.	 Flashes four times (5CH)	—	 Flashes four times (7CH)	—	Inoperable	Operable	There are 5 channels in the default setting.	P.78	
	5 Changing the aileron and elevator rudder angles	Press the power switch four times. Red LED flashes five times at 60%. Orange LED flashes five times at 100%. Press the start switch to change between 60% and 100%.	 Flashes five times (60%)	—	 Flashes five times (100%)	—	Inoperable	Operable	There are 60% in the default setting. Use 60% for S.R.B Quark SG.		
	6 Changing the direction of the tail motor rotation	Press the power switch five times. Red LED flashes for counter-clockwise rotation. Orange LED flashes for clockwise rotation. Press the start switch to change the rotation direction.	 Flashes six times (Counter-clockwise)	—	 Flashes six times (Clockwise)	—	Inoperable	Operable	Counter-clockwise rotation is selected in the default setting. Use counter-clockwise rotation only for S.R.B Quark SG.	P.79	
	7 Data reset	Press the power switch six times.	 Alternate flashing	—	 Alternate flashing	—	Inoperable	Operable		P.79	
	Save settings	Press down the power switch and the start switch simultaneously for three seconds, and then turn off the power.	—	—	—		Stops	Stops			
Gyro sensitivity adjustment mode	Switching to the gyro sensitivity adjustment mode	After disengaging the safety device, press the start switch while keeping the throttle stick of the transmitter at the slowest position.	—	 Alternate flashing	—		Operable	Operable		P.77	
	Adjusting the gyro sensitivity	Turn the RUD ATT volume to adjust the sensitivity.	—	 Alternate flashing	—	—	Operable	Operable	The RUD ATT volume becomes the gyro sensitivity adjustment volume.	P.77	
	Save settings	Hold down the start switch and press the power switch for three seconds to turn off the power.	—	—	—		Stops	Stops	After the sensitivity adjustment is complete, be sure to return the RUD ATT volume to the original position.	P.77	

* Functions in shaded cells are not used with the S.R.B. EC145.

S.R.B EC145 Control Unit Error Display List

	Red LED	Green LED	Orange LED	Motor sound	Throttle	Servo	Item	Content of error	Countermeasures	
Error display	—	—	 Flashes Two times	 →	Inoperable	Inoperable	Poor reception	When the signal is not received properly: Before disengaging the safety device After disengaging the safety device	The flying unit restores when the signal is properly received. Extend the antenna. Check that there are no other radio-controlled devices using the same frequency nearby.	
	—	—	 Flashes Two times	—	Operates slowly	Neutral	Low voltage protection	When the battery voltage is low	2 cell 6.0 V or less 3 cell 9.0 V or less	To restore, turn the control unit off and then turn it back on again. Recharge the battery immediately.
	—	—	 Flash (Slowly)	—				Temperature protection	The motor heats up abnormally	To restore, turn the control unit off and then turn it back on again. Do not attempt to use the motor until it has cooled down.
	—	—	 Flash (Fast)	—	Operable	Operable	Temperature protection diagnosis	Main motor heats up	When there is a temperature protection error, press the start switch to display the type of error.	
	 On	—	—	—				Tail motor heats up		
	—	 On	—	—				Main and tail motors heat up		
	—	—	 On	—	Inoperable	Inoperable	Initialization error	When the power is turned on, the unit did not initialize properly.	Turn the power off and then turn it back on again. When an initialization error occurs, press the start switch to display the type of error.	
	 Alternate flashing	—	—	—			Gyro sensor error	Inoperable Be careful not to move the flying unit until initialization is complete.		
	 Flashes once	—	—	—			Initialization error diagnosis	Motor controller error		
	 Flashes Two times	—	—	—				Battery voltage inappropriate	2 cell 6.8 V or less 8.7 V or more 3 cell 10.2 V or less	Check to ensure that the three cell batteries are connected correctly. If the voltage of the three cell batteries is too low, recharge them immediately.
	 Flashes three times	—	—	—				Power Off error	Cannot turn the power off	
	—	 Flashes four times	—	 →	Operable	Power Off error	Cannot turn the power off			

List of adjustment items in the S.R.B EC145 control unit

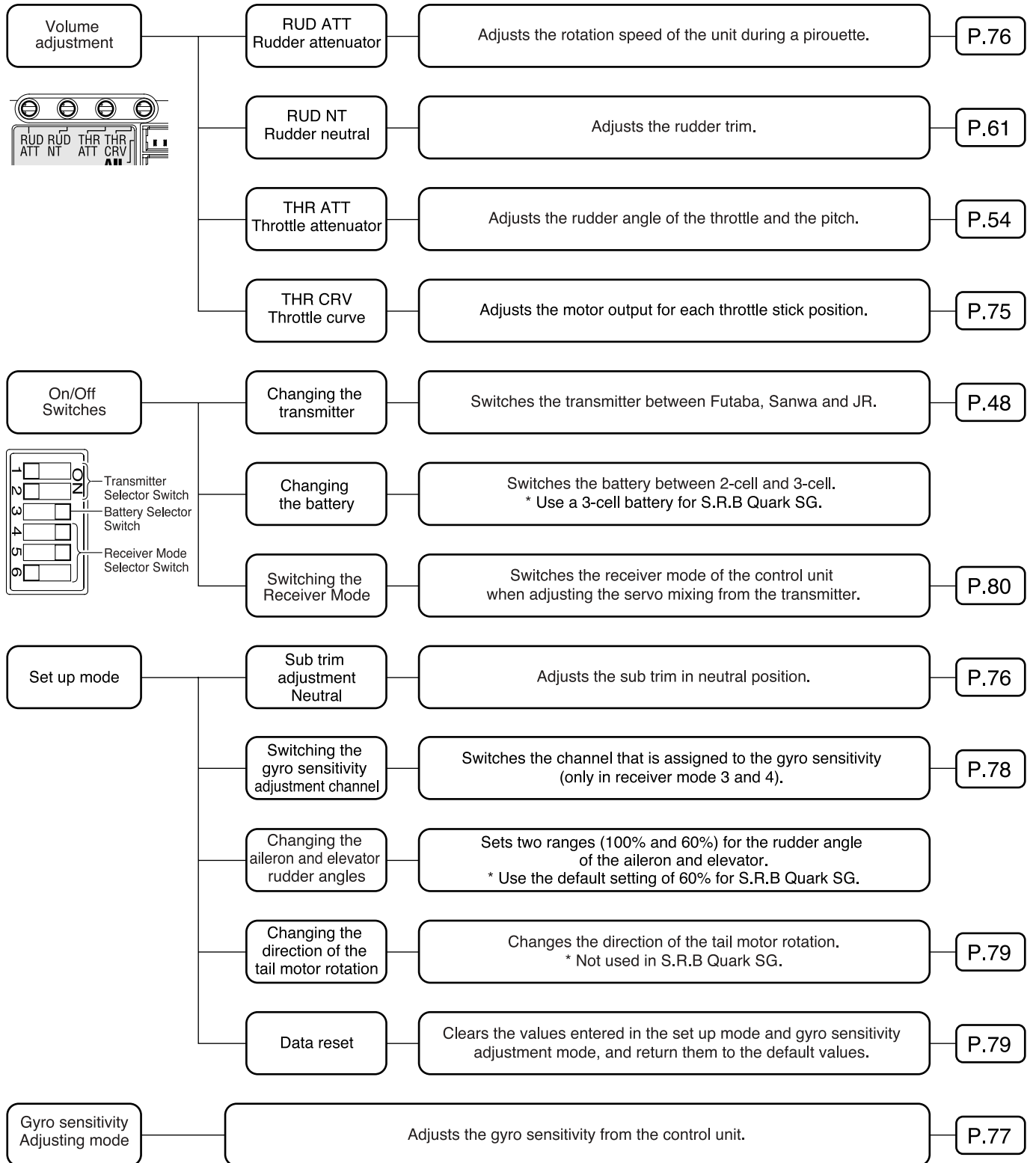

List of switches

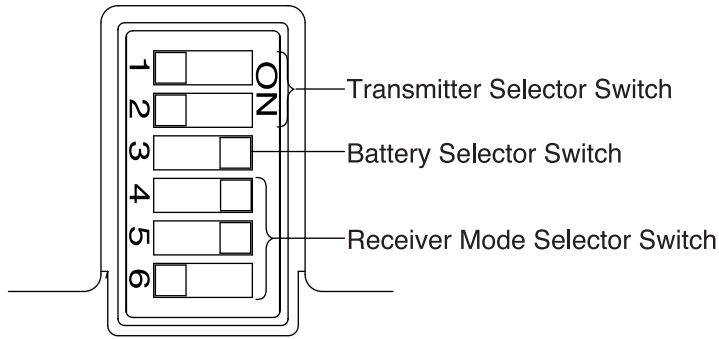

Transmitter Selector Switch

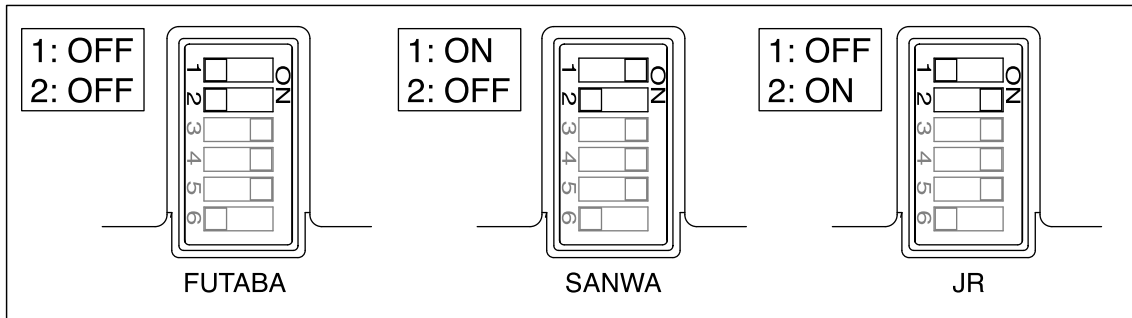

Battery Selector Switch

ON: 3 cell
OFF: 2 cell

Receiver Mode Selector Switch

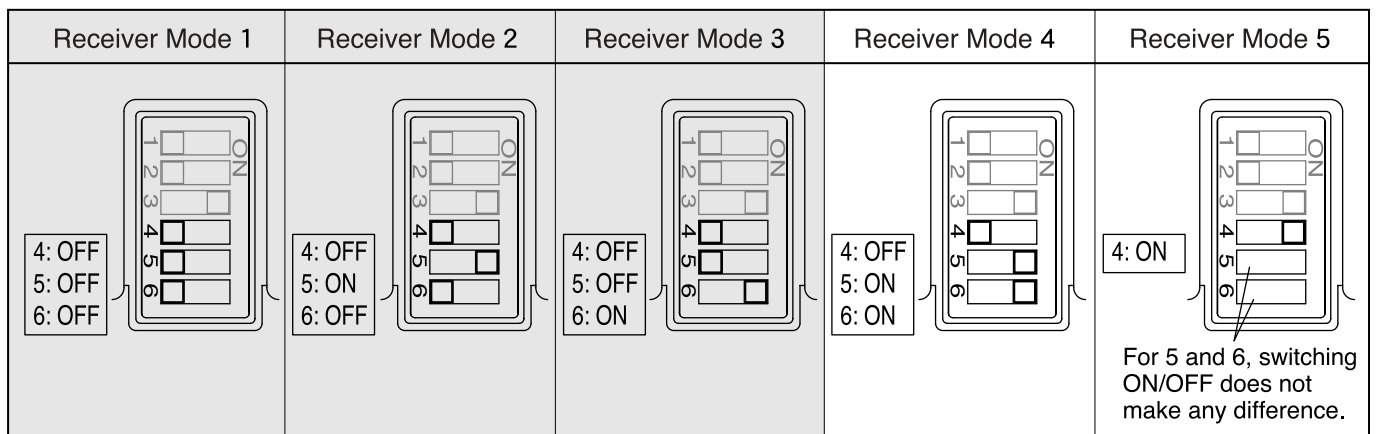

Do not use.

MEMO

MEMO



ヒロボ株式会社

広島県府中市桜が丘3-3-1 〒726-0006
TEL: (0847)40-0088(代) FAX: 47-6108
<http://model.hirobo.co.jp/>

HIROBO LIMITED

3-3-1 SAKURAGAOKA, FUCHU-SHI,
HIROSHIMA-PREF., JAPAN 〒726-0006
TEL: 81-847-40-0088 FAX: 81-847-47-6108
<http://model.hirobo.co.jp/english/>

Note

- ① Reproduction of this manual, or any part thereof, is strictly prohibited.
- ② The contents of this manual are subject to change without prior notice.
- ③ Every effort has been made to ensure that this manual is complete and correct. Should there, however, be any oversights, mistakes or omissions that come to your attention, please inform us.
- ④ Item ③ notwithstanding, we cannot be responsible for events related to the operation of your model.

First printing	June 2011
Second printing	July 2011
Third printing	November 2011

H.T.L