

It is of vital importance, before attempting to operate your engine, to read the general 'SAFETY INSTRUCTIONS AND WARNINGS' in the following section and to strictly adhere to the advice contained therein.

Also, please study the entire contents of this instruction manual, so as to familiarize yourself with the controls and other features of the engine.

SAFETY INSTRUCTIONS AND WARNINGS ABOUT YOUR O.S. ENGINE

Remember that your engine is not a "toy", but a highly efficient internal-combustion machine whose power is capable of harming you, or others, if it is misused or abused. As owner, you, alone, are responsible for the safe operation of your engine, so act with discretion and care at all times. If at some future date, your O.S. engine is acquired by another person, we would respectfully request that these instructions are also passed on to its new owner.

The advice which follows is grouped under two headings according to the degree of damage or danger which might arise through misuse or neglect.

⚠️ WARNINGS

These cover events which might involve serious (in extreme circumstances, even fatal) injury.

⚠️ NOTES

These cover the many other possibilities, generally less obvious sources of danger, but which, under certain circumstances, may also cause damage or injury.

⚠️ WARNINGS

Never touch, or allow any object to come into contact with, the rotating parts.

Gasoline is poisonous. Do not allow it come into contact with the eyes or mouth. Always store it in a clearly marked container in a cool and dark place and out of the reach of children. There is a possibility that it may damage your health.

1) This engine is designed to expressly be run by gasoline fuel.

Use regular gasoline. (No need to use high octane gasoline.)

Mix commercially available 2 stroke engine oil with a 25:1 ratio. Pre-mixed gasoline is also usable but do not use such a pre-mixed gasoline which requires the needle settings far away from the factory settings, otherwise needle settings would be very difficult.

2) Carburetor is set at the factory when the engine leaves the factory.

First run the engine with this factory settings. Refer to the INITIAL OPENING OF THE NEEDLES described later concerning the factory settings.

3) Throttle opening at hovering varies according to the model and silencer used.

With 20~40% throttle opening from the fully closed position, hovering can be done. If you would like to do hovering with the throttle stick position on the transmitter at around neutral, be sure to make a throttle curve on the transmitter. Refer to the Fig. 2 for details.

4) Be aware of long flight time due to low fuel consumption.

Be sure to use a power source of more than 1,500mA capacity for receiver when a more than 15 minutes flight is expected. Also, it is suggested to check the remaining level frequently and charge the batteries if necessary.

5) It is recommended to use 2.4GHz transmitter/receiver.

Since a gasoline engine uses a spark ignition system it is possible that radio frequency noise from the ignition module can interfere with the receivers operation if a 72MHz or 40MHz radio is used, It is recommended that a 2.4GHz radio system be used which is not effected by radio frequency noise.



Gasoline is highly flammable. Keep it away from an open flame, excessive heat, sources of sparks, or anything else which might cause it to ignite. Do not smoke or allow anyone else to smoke near to it.



Carry out the mixing of the gasoline and oil outdoors or in a well ventilated place away from any source of fire to prevent the possibility of a fire.



Refill the fuel tank only after the engine is well cooled down, or there is a danger of fire.



Model engines generates considerable heat. Do not touch any part of your engine until it has cooled. Contact with the muffler (silencer), cylinder head or exhaust header pipe, in particular, may results in a serious burn.

Observe the laws and regulations in each country and district concerning the usage, transportation and storage of gasoline. Ask details at fire station in each district.

Never operate your engine in an enclosed space. Model engines, like automobile engines, exhaust deadly carbon-monoxide. Run your engine only in an open area.

Do not operate the engine nor model alone, or there is a possibility of injury.

⚠️ NOTES

This engine was designed for model helicopters. Do not attempt to use it for any other purpose.

Start the engine only after installing it in the model, or there is a possibility of injury.

Be sure to use an effective silencer (muffler). Frequent exposure to an open exhaust may eventually impair your hearing. Such noise is also likely to cause annoyance to others over a wide area.

Mount the engine in your model securely, following the manufacturers' recommendations.

For their safety, keep all onlookers (especially small children) well back (at least 10 meters) when preparing your model for flight.

When checking a spark plug with the power source on, do not hold the plug, plug cap, high tension cord, or you will get a shock.

Take care that loose clothing (ties, shirt sleeves, scarves etc.) do not come into contact with the rotor. Do not carry loose objects (such as pencils, screwdrivers, etc.) in a shirt pocket from where they could fall through the rotor disc.

Be sure to use an electric starter and wear safety goggles and gloves when starting the engine, or you will be injured.

Always check the throttle linkage. If it is disconnected, throttle action becomes uncontrollable, which may result in a serious accident.

Use an electric starter for this engine. The wearing of safety glasses is also strongly recommended. Press the rotor head down securely.

Do not run the engine at high rpm abruptly after starting the engine, or you will be injured by rotating rotor.

Be sure to carry out adjustments of the high speed needle and slow speed needle after stopping the engine.

If you have to carry the model to the take-off point with the engine running, be especially cautious. Hold the rotor securely and keep well clear of spectators.

Switch off the ignition module to stop the engine or fully close the throttle valve via the transmitter to shut off the fuel supply. Otherwise there is a possibility of injury.

Immediately after the engine is stopped, the engine may start with a crank even when the ignition switch is off. Do not crank the engine, or there is a possibility of injury.

Be sure to install an externally operable switch for the ignition system battery to stop the engine if it is started unintentionally with the radio transmitter turned off or there is the possibility of injury.

Connect the throttle linkage so that the engine can be stopped via radio operation.

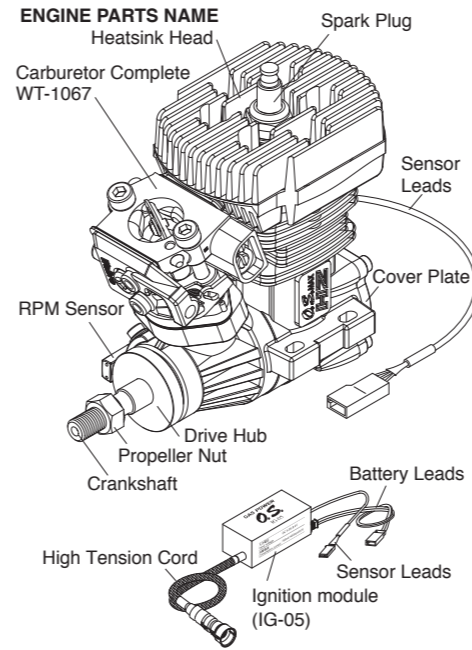

NOTES ON INSTALLING COOLING FAN AND CLUTCH

Do not grip the engine mounting beams with a vise, or the crankcase will be distorted which will result in engine breaking. Do not use a tool which locks piston when installing a cooling-fan and clutch, or top of the piston may be damaged. Also, do not insert a screw driver or the similar into the exhaust port. It is recommended to use Crankshaft Clamp 91/105/GT15 (Code No.71530530) available as an optional tool.

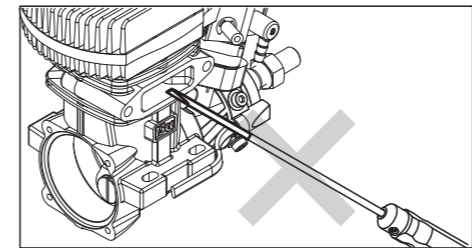

INSTALLATION OF THE ENGINE

Install the cooling fan and clutch on the engine, then install the engine in the model referring to the instruction manual supplied with the model.

At this time some small modifications are required so that the carburetor parts may not interfere with the cooling duct.

CARBURETOR PARTS NAME

Install the Throttle Valve Lever and Choke Valve Lever on the carburetor with the screw and nut supplied with them respectively after installing the engine in the model. Since the Choke Valve Lever is manual, install it so that you may move it with your fingers.

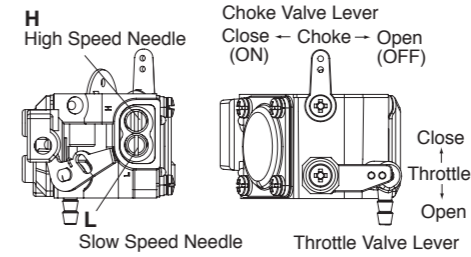
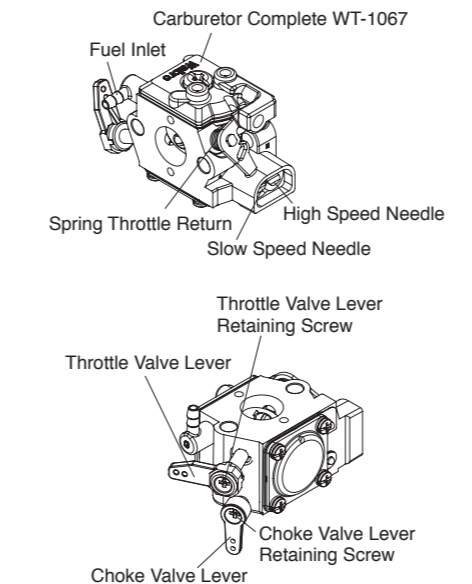

INITIAL OPENING OF THE NEEDLES

This carburetor is equipped with the following two needles.

L: Slow Needle

Open it one and 1/4 turns from the fully closed position. This is to adjust the fuel mixture from idling to hovering.

H: High Needle

Open it one and 3/4 turns from the fully closed position. This is to adjust from hovering to the flight up in the air.

The initial opening is just a basic position and not necessarily the optimum position. Carry out adjustments according to the procedures described in the NEEDLE ADJUSTMENTS section.

LINKAGE TO THE CARBURETOR

Select either F lever or J lever of the Throttle Valve Lever supplied according to the servo used. Select a hole so that both servo horn and Throttle Valve Lever make right angle against the linkage rod. Cut off the levers not in use with nippers.

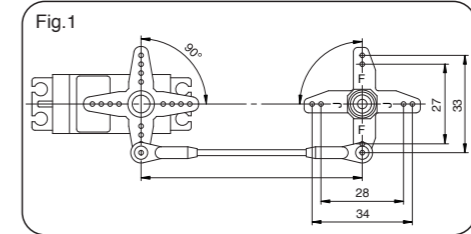
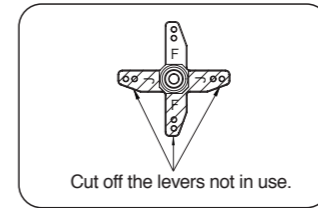

Carry out the linkage making sure of the moving direction of the throttle valve. Moving angle of the throttle valve from fully closed to fully open is 75 degrees. Connect the throttle linkage so that the engine can be stopped via radio operation. Throttle opening when starting should be approx. 3~4 degrees from fully closed position. Never set higher opening when starting, or the clutch engages and rotor starts rotating upon starting the engine, which may injure you.

When using the PowerBoost Pipe GT15HZ, set the linkage with differential so that the throttle opening at hovering may become approx. 20% of the total movement. In case of the E-4051 silencer, throttle opening at hovering should be approx. 40% of the total movement. These small openings are due to the carburetor construction which has larger opening area with smaller opening angle.

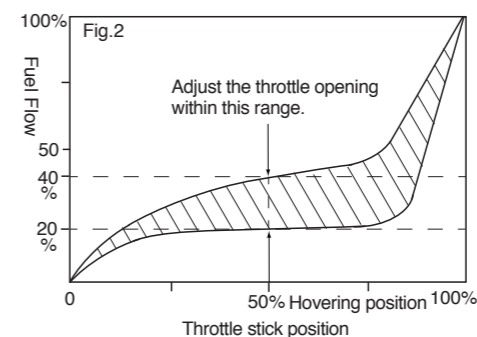

IGNITION MODULE

This is an equipment to ignite a spark plug. Install the plug cap on the plug by using force to push it to the root. Then, install the module in the model.

Major specifications

- Consumption current is 750mA/14,000rpm/6.0V. Use a power source of more than 1500mAh capacity.
- The voltage of power source is 4.8~8.4V (rated). (Ni-Cd, Ni-MH 4~6 cells, Li-Po, Li-Fe 2 cells)

Installation

- Install the ignition module taking sufficient anti-vibration measures.
- Connect the sensor leads of the igniter module (while, red, black three parallel wires) to the sensor leads from the engine.
- Connect the battery leads of the igniter module (red, black two parallel wires) to the power source.
- Install the module to the place where good ventilation is secured because it becomes hot when the engine runs.
- Hold the high tension cord to the frame to prevent from breaking due to vibration.

FUEL

Use regular gasoline. No need to use high octane gasoline. Mix commercially available 2 stroke engine oil with a 25:1 ratio.

We have checked and recommend the following oils. Zenoah Genuine FC Class

KLOTZ ModelLube®

AMSOIL Saber

With these oils, you can set the needles without changing the factory settings too much.

Gasoline is highly flammable. Carry out the mixing of the gasoline and oil outdoors or in a well ventilated place away from any source of fire to prevent the possibility of a fire.

With a gasoline engine, passages in the carburetor are narrower than that of a glow engine, and therefore very sensitive against foreign matter such as dust. It is suggested to use optional accessory Super Filter L (Code No. 72403050) when filling a tank in the model from a container used for transportation or storing.

FUEL TANK & LINES

- Use a tank designed for gasoline. (Tanks designed for glow fuel use a rubber cap which is deteriorated by gasoline.)
- For tubing inside the tank use fluoro-rubber or nitrile rubber of 2.5~3.0mm ID. Replace tubing inside the fuel tank every six month. Since the model attitude changes vigorously, flexible tube and heavy enough weight are required. It is suggested to use optional accessory Non-Bubble Weight (Code No. 71531010) for it.
- This engine does not require a muffler pressurized fuel system but be sure to provide an air vent.
- Connect the tank and carburetor. Be sure to use the tube resistant to gasoline. TYGON®F-4040 (Yellow color), nitrile rubber or fluoro-rubber of more than 3mm ID would be fine.
- Be sure to install an in-line fuel filter between the tank and carburetor to prevent foreign matter in the tank from entering the carburetor. Clean the filter periodically.

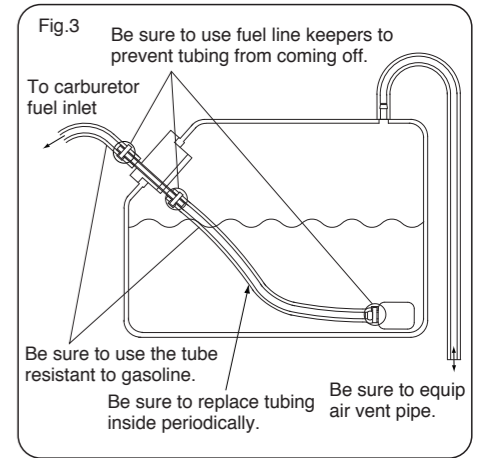

ABOUT THE ENGINE

This is a two-stroke gasoline engine expressly designed for 91 size R/C helicopters. The engine is supplied with a sparkplug and ignition module and special oil for fuel. The engine is equipped with a specially developed WT-1067 Walbro pump carburetor that assures stable running through out the entire operating range.

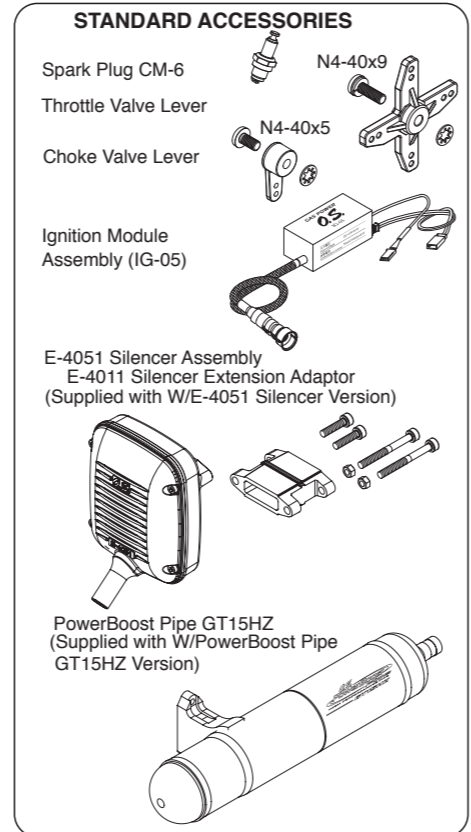

SILENCER

Two types of silencers designed expressly for the GT15HZ are offered. Choose one according to the type of flying intended.

PowerBoost Pipe GT15HZ

It develops very stable power characteristics at both hovering and flight in the air. As to handling, refer to the instruction manual supplied with the pipe.

E-4051 Silencer

This is a compact and light weight aluminum die-cast silencer. It is designed to be effective especially at hovering, and it would be suitable for scale models where mounting space is limited, and for training hovering.

When you need to use extension adaptor supplied according to the frame configuration of the model, install it as per the Fig. 4.

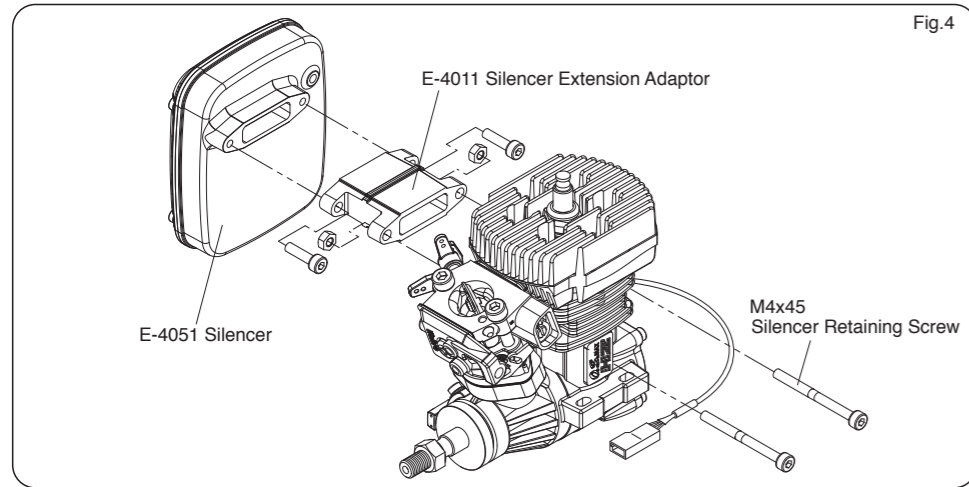

STARTING

Start the engine with the following procedure.

- Fill the tank with mixed gasoline.
- Turn the transmitter switch ON and check the movement of each servo.
- Make sure the throttle opening is set at the idling position.
- Apply an electric starter for several seconds. Note that the correct rotating direction of the starter is counter-clockwise facing the engine.
- Make sure the fuel has reached the carburetor.
- Only when the fuel does not reach the carburetor with keeping applying the starter, set the choke lever ON.
- With the choke ON apply the starter for 5 seconds and make sure the fuel has reached the carburetor. Do not apply the starter more than 10 seconds, or the engine will be over-primed.
- Set the choke lever OFF.
- Turn on the ignition switch, then apply the starter.

NEEDLE ADJUSTMENTS

Carry out the needle settings as follows.

- If the idling is stable, advance the throttle stick gradually to take off. If the take-off is done normally, there is no problem. If there is a problem, carry out adjustments according to the symptoms.
 - If the engine responds sluggishly to increase rpm, turn the slow needle right 5 degrees and try a take-off again. Repeat this procedure until the engine accelerates smoothly checking the change by adjustment each time.
 - If the engine hesitates before picking up speed or cease firing, the mixture is too lean. Turn the slow needle left 10 degrees, and repeat this procedure.

Generally a gasoline engine is more sensitive to a lean mixture in comparison to a glow engine and will over-heat and stop without warning. The engine should always be run with a slightly rich mixture setting.

- When the hovering is done without problem, measure the main rotor rpm.
 - If the main rotor rpm are higher than 1,500rpm, lower the throttle curve so that the engine rpm at hover is lowered. Adjust the throttle curve referring to Fig. 2 in the LINKING TO CARBURETOR section. Turn the low speed needle left 3 degrees so that the mixture at hover will be richer.
 - If the rotor rpm is low and the model loses altitude during hovering. The slow speed mixture is probably set a little too rich. Turn the slow speed needle right 3 degrees.
- After confirming stable hovering, start the running-in consuming 2~3 liters of fuel. Carry out the running-in taking time and checking the remaining level of the receiver battery due to much lower fuel consumption with a gasoline engine. Running temperature of a gasoline engine even with a normal running comes to around 130°C. Never touch the engine nor silencer, or you will get a serious burn.

- Effective adjusting range of each needle is shown in the diagram below.

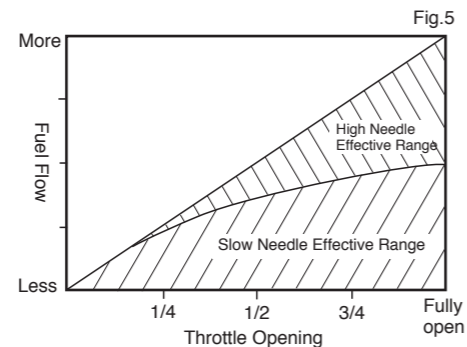

As you see in it, the slow needle is effective through the entire throttle opening range and the high needle is effective at low of below 1/4 throttle opening position. Generally, a gasoline engine carburetor has broader cross range of the high needle and the slow needle. It should be noted both needles are effective from the hovering range.

- Before attempting flight in the air after completing running-in, it is suggested to feel the change by the high needle. At this moment, the high needle is kept at the basic position. Try hovering after turning the high needle left 5 degrees. You will feel the change of hovering since the high needle is effective from the throttle opening for hovering.

- Switch the flight mode and start the flight in the air. First, observe the engine running carefully. If at full throttle engine quits or over-rev with small pitch angle, the high needle is set lean. With a gasoline engine, if needle is set lean, hesitation in picking up speed and engine quit may happen. It is suggested to make sure that the high needle is set a little richer and close it gradually.

- Even with setting the needle richer, if the maximum pitch angle of the main rotor is too big, excess force will be imposed on the engine, which will result in overheating and damage of the engine. Also, if the engine is over-revved with small pitch angle, engine temperature increases and results in overheating. Set it so that maximum rotor RPM during speed forward flight may not exceed 1,750. It should be well noted the relationship of the throttle opening and pitch angle is very important.

MAINTENANCE AFTER THE DAY'S FLIGHTS

- Fill the carburetor with fuel at the conclusion of a day's flying. (Pay careful attention to fire and ignition source when carrying and storing the model.) If the engine is stored without filling the carburetor with fuel, inside parts will dry out and not work properly at the next running. If the engine quits out of fuel, refill the carburetor with fuel.
- With a gasoline engine rust hardly occurs. Check the exterior to make sure there is nothing wrong and wipe off any oil residue.
- Use gasoline to clean the outside of the carburetor. Do not use kerosene, or the inside parts will be damaged. Clean the outside only because the inside parts are sensitive to foreign matter.
- After cleaning the engine, dry it well then inject a small quantity of oil used to mix fuel and rotate the crankshaft several times to distribute the oil well inside the engine.
- Store the batteries for the ignition and the receiver removing from the model. In case of Li-Po batteries, utmost care should be taken not to get fired accidentally.

O.S. GENUINE PARTS & ACCESSORIES

- SPARK PLUG CM-6 (NGK) (71669000)

- E-4051 Silencer Assembly (27426010)

- PowerBoost Pipe GT15HZ (72148000)

- CRANKSHAFT CLAMP 91/105/GT15 (71530530)

- SUPER FILTER (S) (72403051) (L) (72403050)

- NON-BUBBLE WEIGHT (S) (71531010)

- FLUORORUBBER TUBE ID. 2mm x OD. 4mm Length 500mm (28382100) ID. 3mm x OD. 5mm Length 500mm (28382200)

ENGINE EXPLODED VIEW & PARTS LIST

*Type of screw
C...Cap Screw

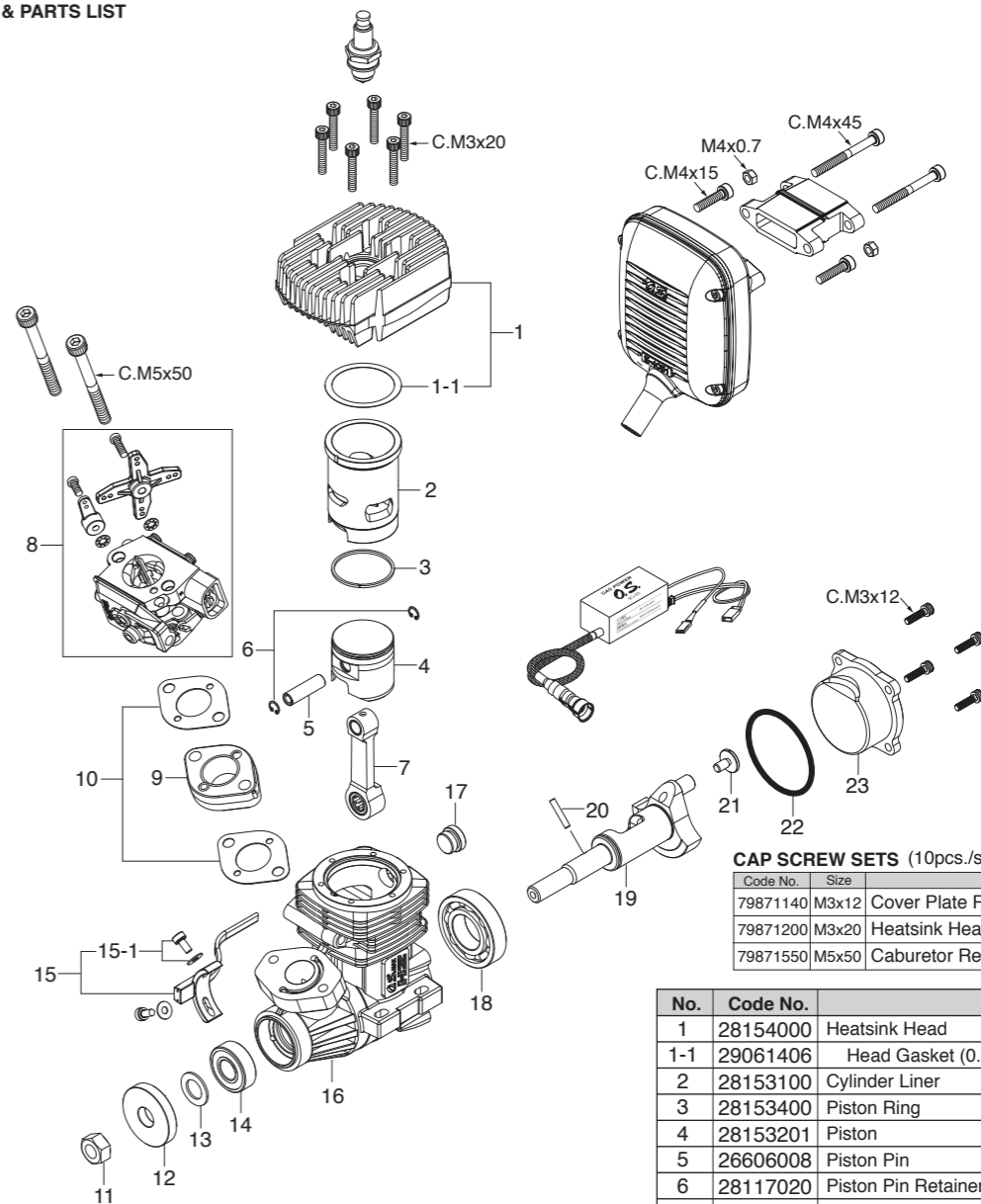

CAP SCREW SETS (10pcs./sets)

| Code No. | Size | Pcs. used in an engine |
|----------|-------|---------------------------------------|
| 79871140 | M3x12 | Cover Plate Retaining Screw (4pcs.) |
| 79871200 | M3x20 | Heatsink Head Retaining Screw (6pcs.) |
| 79871550 | M5x50 | Caburetor Retaining Screw (2pcs.) |

| No. | Code No. | Description |
|------|----------|---|
| 1 | 28154000 | Heatsink Head |
| 1-1 | 29061406 | Head Gasket (0.2mm) |
| 2 | 28153100 | Cylinder Lining |
| 3 | 28153400 | Piston Ring |
| 4 | 28153201 | Piston |
| 5 | 26606008 | Piston Pin |
| 6 | 28117020 | Piston Pin Retainer |
| 7 | 28155000 | Connecting Rod |
| 8 | 28181000 | Carburetor Complete (WT-1067) |
| 9 | 28169450 | Thermo Insulator |
| 10 | 49415000 | Carburetor Gasket (2pcs.) |
| 11 | 45010002 | Propeller Nut |
| 12 | 28158000 | Drive Hub |
| 13 | 46120000 | Thrust Washer |
| 14 | 26731010 | Ball Bearing (F) |
| 15 | 74002320 | Rotation Sensor |
| 15-1 | 74002321 | Rotation Sensor Retaining Screw Set (2pcs.) |
| 16 | 28151000 | Crankcase |
| 17 | 28151300 | Crankcase Plug |
| 18 | 29030001 | Ball Bearing (R) |
| 19 | 28152000 | Crankshaft |
| 20 | 44408100 | Drive Pin |
| 21 | 28152100 | Crank Pin Stop Screw |
| 22 | 27414020 | Cover Gasket |
| 23 | 28157000 | Cover Plate |
| | 74002610 | Ignition Module (IG-05) |
| | 71669010 | Spark Plug CM-6 (Rcexl) |
| | 29781375 | Throttle Valve Lever Assembly (W/washer) |
| | 29781355 | N4-40x9 Screw |
| | 29781360 | Choke Valve Lever Assembly |
| | 29781350 | N4-40x5 Screw |
| | 27426010 | E-4051 Silencer Assembly |
| | 26625510 | E-4011 Extension Adaptor |
| | 27426210 | Silencer Retaining Screw Set |

THREE VIEW DRAWING Dimensions (mm)

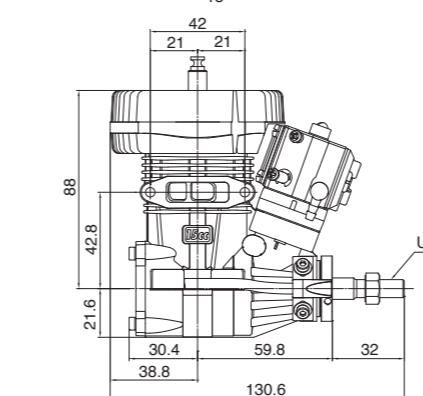
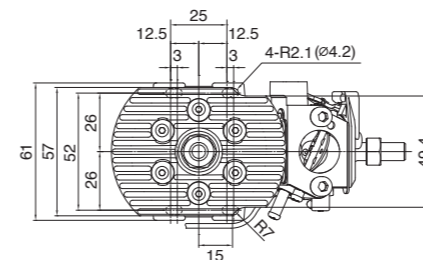

SPECIFICATIONS

| | |
|------------------|---|
| Displacement | 14.95 cc / 0.912 cu.in. |
| Bore | 27.7 mm / 1.091 in. |
| Stroke | 24.8 mm / 0.976 in. |
| Output | 2.8 ps / 2.76 hp / 14,000 r.p.m. |
| Practical R.P.M. | 2,000-16,000 r.p.m. |
| Weight | 748.6 g / 26.41 oz. (Engine) 92.0 g / 3.25 oz. (Ignition module) 144 g / 5.08 oz. (E-4051 Silencer Assembly) 197.5 g / 6.97 oz. (PowerBoost Pipe GT15HZ) |

The specifications are subject to alteration for improvement without notice.



O.S. ENGINES MFG. CO., LTD.

6-15 3-Chome Imagawa Higashiumiyoshi-ku
Osaka 546-0003, Japan TEL. (06) 6702-0225
http://www.os-engines.co.jp FAX. (06) 6704-2722